

K6D80



Description

The multi-component sensor K6D80 allows force and torque measurement in three mutually perpendicular axes.

The multi-component sensor K6D80 distinguishes itself by a big measuring range for torques at the same time with the small outer diameter.

With this multi-component sensor of the „second generation“ is used rod construction, which absorbs forces and torques directly on the pitch circle of the fastening thread. Thereby, the maximum stiffness and the biggest measuring range will be achieved for the torques.

The force transmission is applied on the 1 mm raised segments. The inner diameter of segments is used for the centering. Due to segmented, ring-shaped front surface, the optimal force transmission and therefore the best possible reproducibility in the range of about 0,1 % will be obtained.

The multi-component force sensor is very well suited for use in robotics, e.g.

- For collision detection
- "Teach-In"
- Presence detection and error detection
- Force or torque-controlled operation
- Load measurement in medicine, prosthetics, orthopaedic engineering or gait analysis
- Measurement in sports medicine
- Comfort / ergonomics measurements

The force and torque loadings are evaluated e.g. using a GSV-8AS measurement amplifier or an integrated electronic of type GSV-6.

The sensor K6D80 2kN/100Nm is made of aluminium alloy, the sensor K6D80 5kN/250Nm is made of high-strength stainless steel 1.4542.

Dimensions

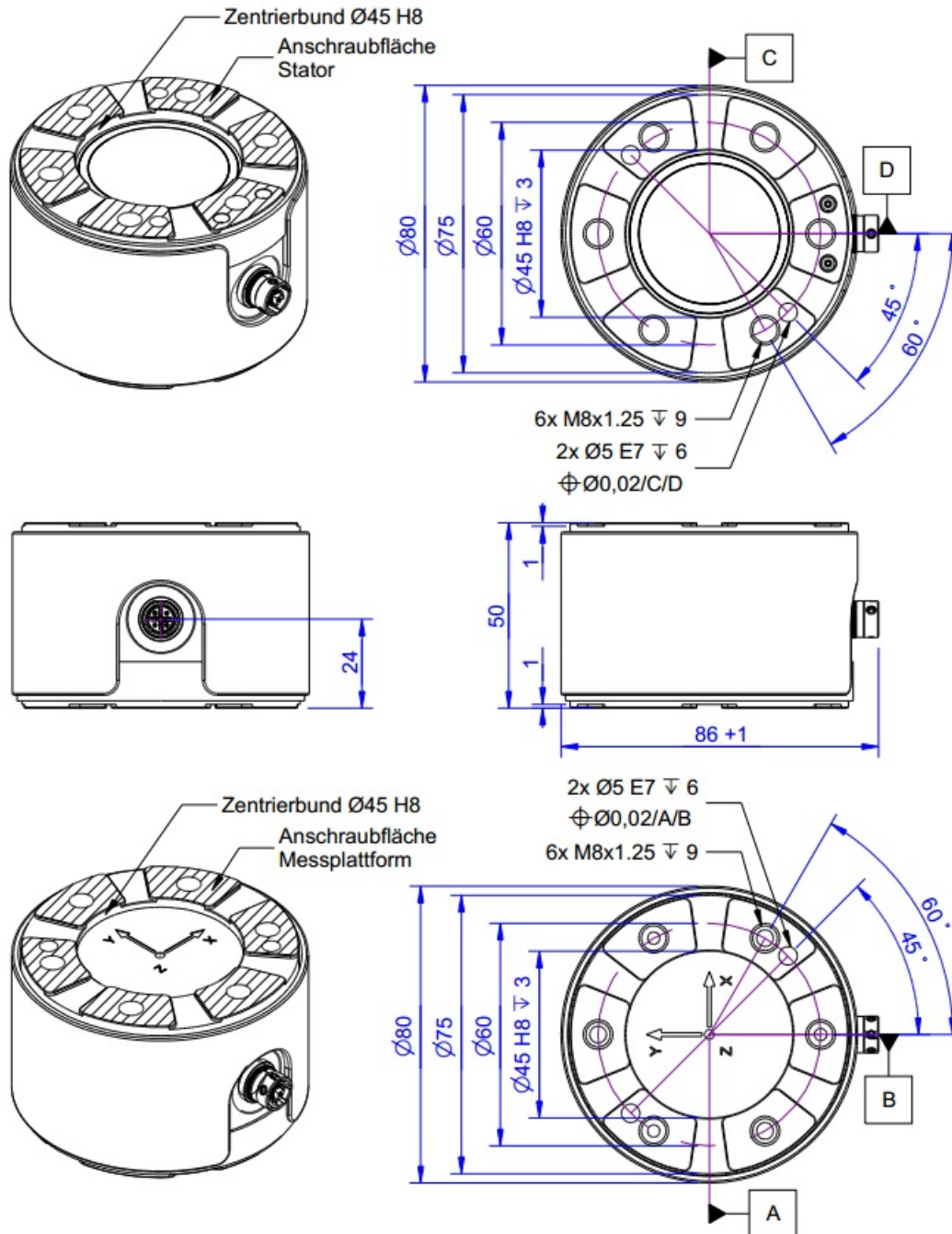

Technical Data - K6D80 500N/20Nm/MP11

| Force sensor | | |
|--------------------------------------------|-----------------------|-------|
| Type | 6-Axis force sensor | |
| Force direction | Tension / Compression | |
| Rated force Fx | 500 | N |
| Rated force Fy | 500 | N |
| Rated force Fz | 1 | kN |
| Force introduction | Inner thread | |
| Dimension 1 | 6x M8x0,1,25 | |
| Sensor Fastening | Inner thread | |
| Dimension 2 | 6x M8x0,1,25 | |
| Operating force | 300 | %FS |
| Rated displacement | 0.05 | mm |
| Twist | 0.04 | rad |
| Dimensions | Ø80 x 50 mm | |
| Height | 50 | mm |
| Length or Diameter | 80 | mm |
| Rated torque Mx | 20 | Nm |
| Rated torque My | 20 | Nm |
| Rated torque Mz | 20 | Nm |
| Torque limit | 300 | % FS |
| Bending moment limit | 300 | % FS |
| Breaking force | 600 | % |
| Electrical Data | | |
| Input resistance | 350 | Ohm |
| Tolerance input resistance | 10 | Ohm |
| Output resistance | 350 | Ohm |
| Tolerance output resistance | 10 | Ohm |
| Insulation resistance | 2 | GOhm |
| Rated range of excitation voltage f | 2.5 ... 5 | V |
| Operating range of excitation voltage f | 1 ... 5 | V |
| Zero signal to | -0.05 | mV/V |
| Zero signal from | 0.05 | mV/V |
| characteristic value range min | 0.5 | mV/V |
| characteristic value range max | 0.8 | mV/V |
| Precision | | |
| Accuracy class | 0,2% | |
| Relative linearity error | 0.1 | %FS |
| Relative zero signal hysteresis | 0.1 | %FS |
| Temperature effect on zero signal | 0.1 | %FS/K |
| Temperature effect on characteristic value | 0.05 | %RD/K |
| Relative creep | 0.1 | %FS |
| Relative repeatability error | 0.5 | %FS |

Technical Data K6D80 1kN/50Nm/MP11

| Force sensor | |
|----------------------|-----------------------|
| Type | 6-Axis force sensor |
| Force direction | Tension / Compression |
| Rated force Fx | 1 kN |
| Rated force Fy | 1 kN |
| Rated force Fz | 2.5 kN |
| Force introduction | Inner thread |
| Dimension 1 | 6x M8x0,1,25 |
| Sensor Fastening | Inner thread |
| Dimension 2 | 6x M8x0,1,25 |
| Operating force | 300 %FS |
| Rated displacement | 0.05 mm |
| Twist | 0.04 rad |
| Material | Aluminium alloy |
| Natural frequency | 2.4 kHz |
| Dimensions | Ø80 x 50 mm |
| Height | 50 mm |
| Length or Diameter | 80 mm |
| Rated torque Mx | 50 Nm |
| Rated torque My | 50 Nm |
| Rated torque Mz | 50 Nm |
| Torque limit | 300 % FS |
| Bending moment limit | 300 % FS |
| Breaking force | 600 % |

Electrical Data

| | |
|-----------------------------------------|-------------|
| Input resistance | 350 Ohm |
| Tolerance input resistance | 10 Ohm |
| Output resistance | 350 Ohm |
| Tolerance output resistance | 10 Ohm |
| Insulation resistance | 2 GOhm |
| Rated range of excitation voltage f | 2.5 ... 5 V |
| Operating range of excitation voltage f | 1 ... 5 V |
| Zero signal to | -0.05 mV/V |
| Zero signal from | 0.05 mV/V |
| characteristic value range min | 0.5 mV/V |
| characteristic value range max | 0.8 mV/V |

Precision

| | |
|--------------------------------------------|------------|
| Accuracy class | 0,2% |
| Relative linearity error | 0.1 %FS |
| Relative zero signal hysteresis | 0.1 %FS |
| Temperature effect on zero signal | 0.1 %FS/K |
| Temperature effect on characteristic value | 0.05 %RD/K |
| Relative creep | 0.1 %FS |

Technical Data - K6D80 2kN/100Nm/MP11

| Force sensor | |
|----------------------|-----------------------|
| Type | 6-Axis force sensor |
| Force direction | Tension / Compression |
| Rated force Fx | 2 kN |
| Rated force Fy | 2 kN |
| Rated force Fz | 5 kN |
| Force introduction | Inner thread |
| Dimension 1 | 6x M8x0,1,25 |
| Sensor Fastening | Inner thread |
| Dimension 2 | 6x M8x0,1,25 |
| Operating force | 300 %FS |
| Rated displacement | 0.05 mm |
| Twist | 0.04 rad |
| Material | Aluminium alloy |
| Natural frequency | 3.3 kHz |
| Dimensions | Ø80 x 50 mm |
| Height | 50 mm |
| Length or Diameter | 80 mm |
| Rated torque Mx | 100 Nm |
| Rated torque My | 100 Nm |
| Rated torque Mz | 100 Nm |
| Torque limit | 300 % FS |
| Bending moment limit | 300 % FS |
| Breaking force | 600 % |

| Electrical Data | |
|-----------------------------------------|-------------|
| Input resistance | 350 Ohm |
| Tolerance input resistance | 10 Ohm |
| Output resistance | 350 Ohm |
| Tolerance output resistance | 10 Ohm |
| Insulation resistance | 2 GOhm |
| Rated range of excitation voltage f | 2.5 ... 5 V |
| Operating range of excitation voltage f | 1 ... 5 V |
| Zero signal to | -0.05 mV/V |
| Zero signal from | 0.05 mV/V |
| characteristic value range min | 0.5 mV/V |
| characteristic value range max | 0.8 mV/V |

| Precision | |
|--------------------------------------------|------------|
| Accuracy class | 0,2% |
| Relative linearity error | 0.1 %FS |
| Relative zero signal hysteresis | 0.1 %FS |
| Temperature effect on zero signal | 0.1 %FS/K |
| Temperature effect on characteristic value | 0.05 %RD/K |
| Relative creep | 0.1 %FS |

Technical Data - K6D80 5kN/250Nm/MP1

| Force sensor | |
|----------------------|-----------------------|
| Type | 6-Axis force sensor |
| Force direction | Tension / Compression |
| Rated force Fx | 5 kN |
| Rated force Fy | 5 kN |
| Rated force Fz | 15 kN |
| Force introduction | Inner thread |
| Dimension 1 | 6x M8x0,1,25 |
| Sensor Fastening | Inner thread |
| Dimension 2 | 6x M8x0,1,25 |
| Operating force | 300 %FS |
| Rated displacement | 0.05 mm |
| Twist | 0.04 rad |
| Material | Stainless steel |
| Natural frequency | 3.6 kHz |
| Dimensions | Ø80 x 50 mm |
| Height | 50 mm |
| Length or Diameter | 80 mm |
| Rated torque Mx | 250 Nm |
| Rated torque My | 250 Nm |
| Rated torque Mz | 250 Nm |
| Torque limit | 300 % FS |
| Bending moment limit | 300 % FS |
| Breaking force | 600 % |

Electrical Data

| | |
|-----------------------------------------|-------------|
| Input resistance | 350 Ohm |
| Tolerance input resistance | 10 Ohm |
| Output resistance | 350 Ohm |
| Tolerance output resistance | 10 Ohm |
| Insulation resistance | 2 GOhm |
| Rated range of excitation voltage f | 2.5 ... 5 V |
| Operating range of excitation voltage f | 1 ... 5 V |
| Zero signal to | -0.05 mV/V |
| Zero signal from | 0.05 mV/V |
| characteristic value range min | 0.5 mV/V |
| characteristic value range max | 0.8 mV/V |

Precision

| | |
|--------------------------------------------|------------|
| Accuracy class | 0,2% |
| Relative linearity error | 0.1 %FS |
| Relative zero signal hysteresis | 0.1 %FS |
| Temperature effect on zero signal | 0.1 %FS/K |
| Temperature effect on characteristic value | 0.05 %RD/K |
| Relative creep | 0.1 %FS |

| | |
|------------------------------|---------|
| Relative repeatability error | 0.5 %FS |
|------------------------------|---------|

Connection Data

| | |
|------------------------|---------------------|
| Connection type | Connector |
| Name of the connection | MP11, 24-pole, male |

Eccentricity and Crosstalk

| | |
|-----------|-------|
| Crosstalk | 1 %FS |
|-----------|-------|

Temperature

| | |
|-------------------------------|---------------|
| Rated temperature range f | -10 ... 70 °C |
| Operating temperature range f | -10 ... 85 °C |
| Storage temperature range f | -10 ... 85 °C |
| Environmental protection | IP65 |

Abbreviation : RD: „Reading“; FS: „Full Scale“;

The application of a calibration matrix is required for the determination of the forces F_x , F_y , F_z and moments M_x , M_y , and M_z from the 6 measurement channels, and to compensate for the crosstalk.

The calibration data are individually determined and documented for the sensor.

The measurement error is expressed individually by the specification of the extended measurement uncertainty ($k = 2$) for the forces F_x , F_y , F_z , and moments M_x , M_y , M_z .

Pin Configuration

| Channel | Symbol | Description | Wire colour | PIN |
|---------|--------|------------------------|--------------|-----|
| 1 | +Us | positive bridge supply | yellow | 14 |
| | -Us | negative bridge supply | green | 13 |
| | +Ud | positive bridge output | white | 1 |
| | -Ud | negative bridge output | brown | 5 |
| 2 | +Us | positive bridge supply | gray | 15 |
| | -Us | negative bridge supply | black | 16 |
| | +Ud | positive bridge output | red | 7 |
| | -Ud | negative bridge output | pink | 6 |
| 3 | +Us | positive bridge supply | brown-blue | 23 |
| | -Us | negative bridge supply | white-red | 24 |
| | +Ud | positive bridge output | brown-red | 12 |
| | -Ud | negative bridge output | white-pink | 4 |
| 4 | +Us | positive bridge supply | white-yellow | 19 |
| | -Us | negative bridge supply | yellow-brown | 20 |
| | +Ud | positive bridge output | brown-green | 9 |
| | -Ud | negative bridge output | white-green | 3 |
| 5 | +Us | positive bridge supply | white-gray | 21 |
| | -Us | negative bridge supply | white-blue | 22 |
| | +Ud | positive bridge output | gray-brown | 10 |
| | -Ud | negative bridge output | pink-brown | 11 |
| 6 | +Us | positive bridge supply | gray-pink | 18 |
| | -Us | negative bridge supply | purple | 17 |
| | +Ud | positive bridge output | red-blue | 8 |
| | -Ud | negative bridge output | blue | 2 |
| - | shield | | transparent | |

Shield: connected with sensor housing;

Manual

Stiffness Matrix K6D80 5kN/250Nm

| | | | | | | |
|-------------|-------------|-------------|-----------|-----------|-----------|----------|
| 164.7 kN/mm | 0,0 | 0,0 | 0,0 | 4117 kN | 0,0 | u_x |
| 0,0 | 164.7 kN/mm | 0,0 | -4117 kN | 0,0 | 0,0 | u_y |
| 0,0 | 0,0 | 712.6 kN/mm | 0,0 | 0,0 | 0,0 | u_z |
| 0,0 | -4117 kN | 0,0 | 346.7 kNm | 0,0 | 0,0 | ϕ_x |
| 4117 kN | 0,0 | 0,0 | 0,0 | 346.7 kNm | 0,0 | ϕ_y |
| 0,0 | 0,0 | 0,0 | 0,0 | 0,0 | 225.3 kNm | ϕ_z |











| Element | Description |
|---------|---------------------------------------|
| [kN/mm] | force- displacement |
| [kNm] | torque- twist |
| [kN] | force- twist and torque- displacement |

Mounting

The forces is applied to an annulus ($\emptyset 75\text{-}\emptyset 45$) on the end faces of the sensor. No force is applied to the area inside the ring.

A centring hole is provided to secure the angular position.

accessories

| Description | Description |
|-----------------------------------------------------------------------------------------------------------------------------------------|-------------------------------------------------------------------------------------------------------------------------------------------------|
|  <p>K6D-CalibrationMatrix SL</p> | Standard calibration matrix "Small load" for the sensors with small measuring ranges |
|  <p>K6D-CalibrationMatrix SL/4</p> | High accuracy calibration matrix for 6-axis force/torque sensors; |
|  <p>GSV-8DS</p> | 8-channel amplifier with USB port, analog output, UART interface. Other versions GSV-8AS CAN with Canbus and GSV-8AS EC with EtherCAT fieldbus. |
|  <p>GSV-8AS</p> | 8-channel amplifier with USB port, analog output, UART interface. Other versions GSV-8AS CAN with Canbus and GSV-8AS EC with EtherCAT fieldbus. |
|  <p>K6D-Adapter Development</p> | Indicative offer for an adapter set, Consisting of e.g. 2 plates, For mounting a device / flange on K6D sensor; |
|  <p>Connection cable MP11/f-M16/24p/m</p> | Connection cable for the K6D sensor to 8-channel measuring amplifier GSV-8AS |
|  <p>Connection cable MP11/f-M16/24p/m/angled</p> | Angled connection cable for the K6D sensor to 8-channel measuring amplifier GSV-8AS |
|  <p>Connection cable MP11/f-D-Sub44HD/m</p> | Connection cable for connecting the K6D sensor to an 8-channel measuring amplifier GSV-8DS SubD44HD |
|  <p>Connection cable MP11/f-D-Sub44HD/m/straight</p> | Straight connection cable for connecting the K6D sensor to an 8-channel measuring amplifier GSV-8DS SubD44HD |
|  <p>Connection cable MP11/f-D-Sub44HD/m/angled</p> | Angled connection cable for connecting the K6D sensor to an 8-channel measuring amplifier GSV-8DS SubD44HD |
|  <p>Connection cable MP11/f-open end</p> | Connection cable for K6D sensor |