

LOAD CELL CHARACTERISTICS

#	CAPACITY	25-50 (LBF)	100-250 (LBF)	100-200 (N)	500-1000 (N)
1	FLEXURE MAT'L	ANODIZED ALUMINUM	STAINLESS STEEL	ANODIZED ALUMINUM	STAINLESS STEEL
2	FLEXURE THREAD	0.25-28 UNF-2B		M6 X 1-6H	

Interface Inc. claims proprietary rights in the information disclosed herein. This drawing is furnished in confidence on the express understanding that neither it nor any reproduction thereof will be disclosed to others or used for the purpose of manufacture or procurement of the article or part shown hereon without written permission of Interface Inc. The drawing shall remain the property of Interface Inc. and shall be returned upon request by Interface Inc.

83558

REVISIONS			
REV.	DESCRIPTION	DATE	APPROVED
A	INITIAL RELEASE	7/25/2022	RMP

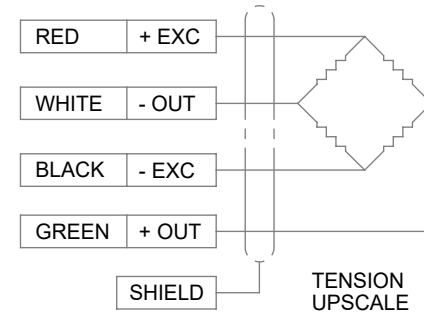
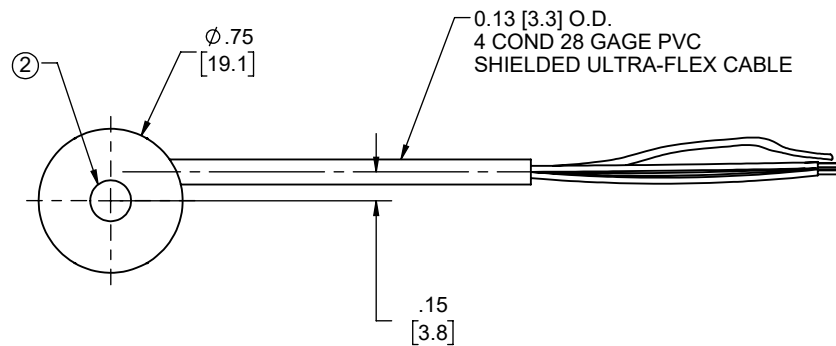
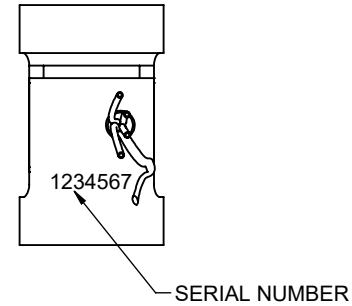
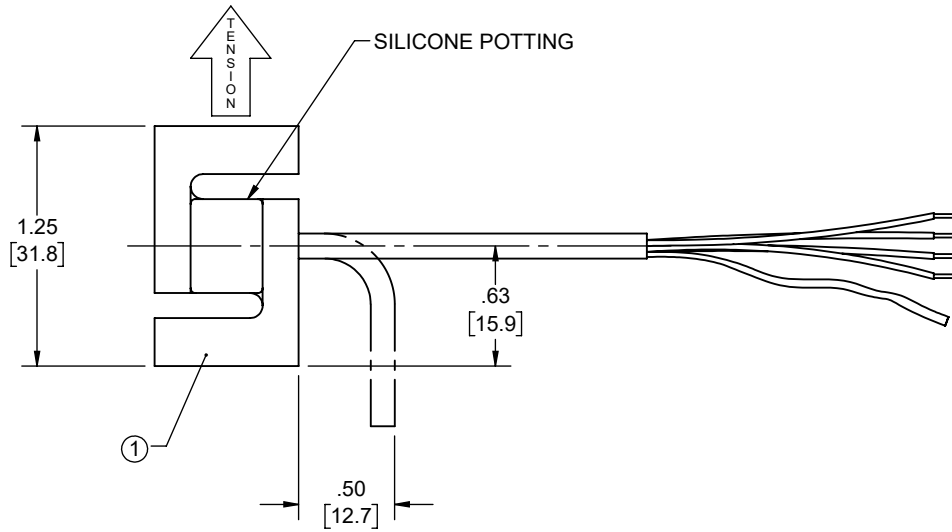

1. STANDARD CABLE LENGTH IS 5 FT [1.5M].
NON STANDARD CABLE LENGTH PER OPTION CODE.

UNLESS OTHERWISE SPECIFIED
DIMENSIONS ARE IN INCHES [mm]
TOLERANCES ARE:
ANGLES $\pm 0^\circ 30'$
.XX $\pm .01$ [0.25]
.XXX $\pm .005$ [0.13]

CREATOR	DATE
DESIGNED: RMP	07/25/22
DETAILED: RMP	7/25/2022
WEIGHT: (APPROX) 0.04 (lbs)	

Interface
FORCE MEASUREMENT SOLUTIONS

7418 E. HELM DRIVE
SCOTTSDALE, AZ 85260 USA

TITLE:
OUTLINE MODEL: SSC-25 THRU 250, 100N THRU 1000N

SIZE: DWG. NO: **83558** REV: **A**

SCALE: 1:1 SHEET 1 OF 1