



Description

The multi-component sensor F6D100 is used for force and torque measurement in three mutually perpendicular axes.

The multi-component sensor F6D100 is equipped with mounting flanges according to DIN EN ISO 9409-1 for industrial robots. The measuring flange of the sensor contains tapped holes M6 on the same pitch circle. The F6D force / torque sensor can be mounted to the robot flange without additional adapters, making it particularly flat and light compared to the K6D series sensors.

The evaluation of the force and moment load is carried out with an integrated electronics type GSV-6.

The sensors are made of an aluminum alloy.

Our robotics partner IPR offers solutions for applications of force / torque sensors.

Dimensions

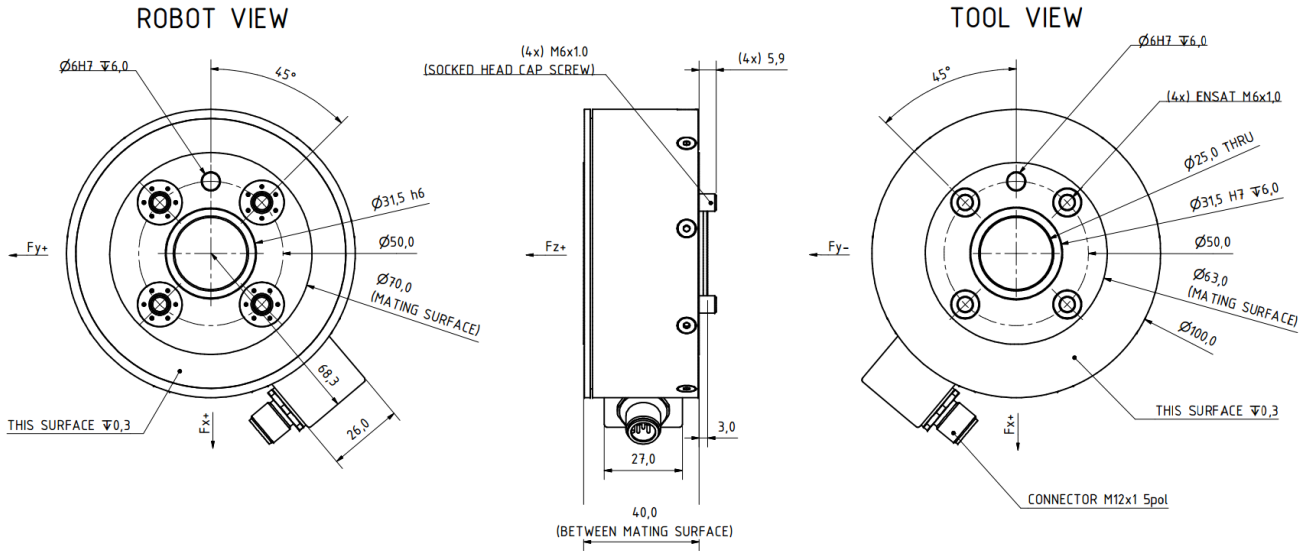

Technical Data

Force sensor	
Type	6-Axis force sensor
Force direction	Tension / Compression
Rated force Fx	200 N
Rated force Fy	200 N
Rated force Fz	400 N
Force introduction	Inner thread
Dimension 1	4xM6
Sensor Fastening	Through bore
Dimension 2	M6
Operating force	300 %FS
Rated displacement	0.05 mm
Twist	0.04 rad
Material	Aluminium alloy
Height	40 mm
Length or Diameter	100 mm
Rated torque Mx	20 Nm
Rated torque My	20 Nm
Rated torque Mz	20 Nm
Breaking force	600 %FS

Electrical Data

Input resistance	1000 Ohm
Tolerance input resistance	50 Ohm
Output resistance	1000 Ohm
Tolerance output resistance	50 Ohm
Insulation resistance	2 GOhm
Rated range of excitation voltage f	2.5 ... 5 V
Operating range of excitation voltage f	1 ... 10 V
Zero signal	1 mV/V
Rated output	0.4 mV/V / FS

Measuring frequency

Data frequency f	10 ... 800 Hz
Sampling frequency	12 kHz

Precision

Accuracy class	1%
Relative linearity error	0.1 %FS
Relative zero signal hysteresis	0.1 %FS
Temperature effect on zero signal	0.1 %FS/K
Temperature effect on characteristic value	0.05 %RD/K
Relative creep	0.1 %FS
Relative repeatability error	0.5 %FS

Supply

Supply voltage f	18 ... 28	V
Current consumption f	100 ... 250	mA

Interface

Type of the interface	can	
Quantity of the interface	1	
Isolation of the interface	2	kV

Connection Data

Connection type	5-Leiter offen	
-----------------	----------------	--

Temperature

Rated temperature range f	-10 ... 70	°C
Operating temperature range f	-10 ... 85	°C
Storage temperature range f	-10 ... 85	°C
Environmental protection	IP64	

Abbreviation : RD: „Reading“; FS: „Full Scale“;

The application of a calibration matrix is required for the determination of the forces F_x , F_y , F_z and moments M_x , M_y , and M_z from the 6 measurement channels, and to compensate for the crosstalk.

The calibration data are individually determined and documented for the sensor.

The measurement error is expressed individually by the specification of the extended measurement uncertainty ($k = 2$) for the forces F_x , F_y , F_z , and moments M_x , M_y , M_z .

Manual

Stiffness Matrix F6D100-50 200N/20Nm

27,3 kN/mm	0,0	0,0	0,0	2185 kN	0,0	u_x
0,0	27,3 kN/mm	0,0	-2185 kN	0,0	0,0	u_y
0,0	0,0	270,6 kN/mm	0,0	0,0	0,0	u_z
0,0	-2185 kN	0,0	248,3 kNm	0,0	0,0	ϕ_x
2185 kN	0,0	0,0	0,0	248,3 kNm	0,0	ϕ_y
0,0	0,0	0,0	0,0	0,0	78,2 kNm	ϕ_z

Element	Description of the context
[kN/mm]	force- displacement
[kNm]	torque- twist
[kN]	force- twist and torque- displacement

Mounting

Pin configuration

Signal	Description	Wire color	PIN
CAN_GND	Mass CAN	brown	1
+24V	Operating voltage 24V	white	2
GND_24V	Mass operating voltage	blue	3
CAN_H	Can High	black	4
CAN_L	CAN Low	grey	5

Calibration matrix

The calibration matrix contains 36 calibration factors for calculating the forces and torques from the 6 output signals of the force sensor. A Labview vi is available for processing the calibration matrix

Measuring amplifier

The measuring amplifier GSV-8DS or GSV-8AS has 24-pole plug connector to connect the 6-axis force/torque sensor. The mechanical forces and torques are calculated from 6 output voltages of each measuring channel with the calibration matrix.

Software

The GSVmulti software is included in delivery with measuring amplifiers GSV-8. The software allows the application of the calibration matrix and the displacement of the coordinate system to represent the torques around a freely selectable reference point.

To create your own software, a Labview VI is available.

Mounting instruction

The force is applied to a circular ring (Ø80-Ø40) on the live end of the sensor. The area inside the circular ring remains unloaded.

A center hole Ø6 serves to secure the angular position.

4x M6 external thread for mounting on robot flange (mounted with Allen key from the tool side, the screws are integrated in the F6D sensor, can not be lost);

4x M6 internal thread for mounting the tool (this flange corresponds again to the robot flange);



Summary: The sensor has M6 internal thread and M6 external thread.

Robotics solutions from IPR

Our robotics partner IPR offers solutions for applications of force / torque sensors in the areas of

- Mounting and handling technology
- Machine loading
- Foundry and blacksmith
- Cavity preservation
- Sealing and damping
- Lack and paint
- Services

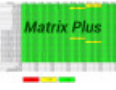
accessories

Description	Description
 K6D-CalibrationMatrix SL	Standard calibration matrix "Small load" for the sensors with small measuring ranges
 K6D-CalibrationMatrix SL/Plus	High accuracy calibration matrix for 6-axis force/torque sensors;
 PCAN-USB Adapter	PCAN-USB adapter for connection to CAN Bus and to PC
 F6D-CAN-Adapter	CAN-adapter to connect an F6D sensor and a PCAN-USB cable;