

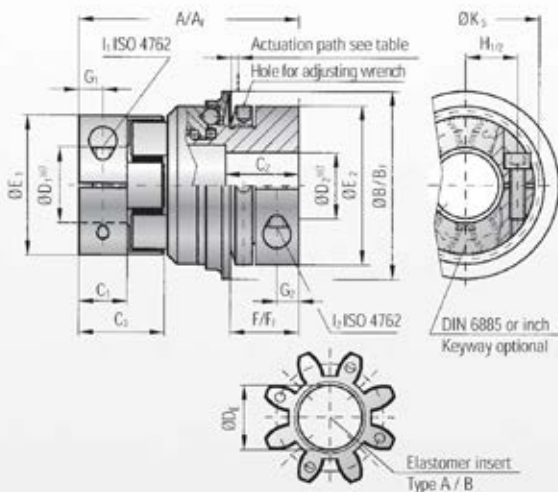

MODEL ES2

TECHNICAL SPECIFICATIONS



Properties:

- reliable torque overload protection
- short compact design
- backlash-free due to patented design
- disengagement within msec.
- high actuation path when disengaging
- electrically insulating
- press-fit design

Material:

Torque limiter: high strength hardened steel with rust protected surface (oxidized)
Clamping hub D₁: up to series 450 high strength aluminum, from series 800 and up steel
Clamping hub D₂: up to series 60 high strength aluminum, from serie 150 and up steel
Elastomer insert: precision molded, wear resistant, and thermally stable polymer

Design:

Two coupling hubs are concentrically machined with concave driving jaws
One side with an integrated torque limiter
The torque limiter is available in single position, multi position or full-disengagement versions.

Tolerance:

On the hub/shaft connection 0,01 to 0,05 mm

W = single position re-engagement

- After the overload has been eliminated, the coupling will automatically reengage precisely 360° from the original disengagement position
- Achievement of the precise synchronous re-engagement due to patented design
- Signal at overload with mechanical switch or proximity sensor

D = Multi position re-engagement

- Coupling re-engages at multiple set angular intervals.
- Immediate availability of the application as soon as the overload has been eliminated.
- Signal at overload with mechanical switch or proximity sensor
- Standard engagement every 60°
- Engagement at 30, 45, 90 and 120 degrees are optional.

F = Full disengagement

- Permanent separation of drive and driven loads in the event of a torque overload.
- No residual friction
- Signal at overload
- Rotating elements slow down freely
- Coupling can be re-engaged manually (Engagement every 60°)

Ordering example

ES2 / 10 / A / W / 14 / 12 / 8 / 4-12 / XX

Model
Series
Type Elastomer insert
Function system (see page 13)
Bore Ø D1 H7
Bore Ø D2 H7
Disengagement torque
Adjustable range
Non standard e.g. VA-Material

All data is subject to change without notice.

The selection of torque limiters

In general the torque limiters are sized according to the necessary disengagement torque. This torque must exceed the nominal torque of the application.



Model ES 2	Series							
	10	20	60	150	300	450	800	
Adjustment range (Nm) possible from -to (approx. values)	T_{KN}	2 - 6 or 4 - 12	10 - 25 or 20 - 40	10 - 30 or 25 - 80	20-70 45-150 80-180	100 - 200 150 - 240 200 - 320	80 - 200 200 - 350 300 - 500	400 - 650 500 - 800 600 - 900
Adjustment range (full disengagement) possible from -to (approx. values)	T_{KN}^f	2-5 or 5-10	8 - 20 or 16 - 30	20 - 40 or 30 - 60	20-60 40-80 80-150	120 - 180 or 160 - 300	60 - 150 100 - 300 250 - 500	200 - 400 or 450 - 800
Overall length (mm)	A	60	86	96	106	140	164	179
Overall length (full disengagement) (mm)	A_f	60	86	96	108	143	168	190
Outer diameter of actuation ring (mm)	B	45	65	73	92	120	135	152
Outer diameter of actuation ring (mm)	B_p	51.5	70	83	98	132	155	177
Fit length (mm)	C_1	10.3	17	20	21	31	34	46
Fit length (mm)	C_2	16	27	31	35	42	51	45
Length of hub (mm)	C_3	20.7	31	36	39	52	57	74
Inner diameter from \emptyset to \emptyset H7 (mm)	D_1	5 - 16	8 - 25	12 - 32	19 - 36	20 - 45	28 - 60	35 - 80
Inner diameter from \emptyset to \emptyset H7 (mm)	D_2	6 - 20	12 - 30	15 - 32	19 - 42	30 - 60	35 - 60	40 - 75
Diameter of the hub (mm)	E_1	32	42	56	66.5	82	102	136.5
Diameter of the hub (mm)	E_2	40	55	66	81	110	123	132
Distance (mm)	F	17	24	30	31	35	45	50
Distance full disengagement (mm)	F_f	16	22	29	30	35	43	54
Distance (mm)	G_1	5	8.5	10	11	15	17.5	23
Distance (mm)	G_2	5	7.5	9.5	11	13	17	18
Distance between centers (mm)	H_1	10.5	15	21	24	29	38	50.5
Screws (ISO 4762/12.9)		M4	M5	M6	M8	M10	M12	M16
Tightening torque of the mounting screw (Nm)	I_1	4	8	15	35	70	120	290
Distance between centers SK-side (mm)	H_2	15	19	23	27	39	41	48
Screws (ISO 4762/12.9)		M4	M6	M8	M10	M12	M16	2x M16
Tightening torque of the mounting screw (Nm)	I_2	4.5	15	40	70	130	200	250
Diameter with screwhead (mm)	K_S	32	44.5	57	68	85	105	139
Approx. weight (kg)		0.3	0.6	1.0	2.4	5.8	9.3	14.3
Moment of inertia (10^{-3} kgm ²)	J_{ges}	0.06	0.25	0.7	2.3	11	22	33.5
Actuation path (mm)		1.2	1.5	1.7	1.9	2.2	2.2	2.2
Type (Elastomer insert)		A B	A B	A B	A B	A B	A B	A B
Inner diameter (Elastomer insert) (mm)	D_i	14.2	19.2	27.2	30.2	38.2	45.2	60.5

1 Nm = 8.85 in lbs

Mounting instructions

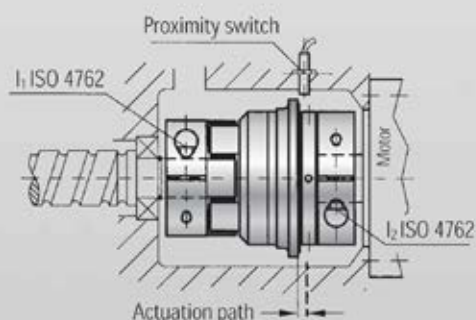

Mounting: Slide the coupling on the shaft ends to the proper axial position. Using a torque wrench, tighten the clamp screws to the correct tightening torque as indicated.

CAUTION! Both clamping hubs have different screws and different tightening torques.

Dismounting: Simply loosen the clamp screw I1, I2 and remove the safety coupling.

Emergency cut off: The axial path of the actuation ring activates the mechanical switch or the proximity sensor.

CAUTION! Upon assembly, it is absolutely necessary to check the function of the switch 100%.