

Installation Information

LIPS[®] P106 INTERNALLY MOUNTED CYLINDER SENSOR WITH EXTERNAL ELECTRONICS

Output Option	Output Description:	Supply Voltage: V _s (tolerance)	Load resistance: (include leads for 4 to 20mA O/Ps)
A	0.5 - 4.5V (ratiometric with supply)	+5V (4.5 - 5.5V)	≥ 5kΩ
B	±5V	±15V nom. (±9 - 28V)	≥ 5kΩ
C	0.5 - 9.5V	+24V nom. (13 - 28V)	≥ 5kΩ
D	±10V	±15V nom. (±13.5 - 28V)	≥ 5kΩ
E	4 - 20mA 2 wire Current Loop	+24V nom. (18 - 28V)	≈ 0 - 300Ω max. @24V ~ 1.2 to 6V across 300Ω {R _L max. = (V _s - 18) / 20 ⁻³ }
F	4 - 20mA 3 wire Sink	+24V nom. (13 - 28V)	≈ 0 - 950Ω max. @24V ~ 3.8 to 19V across 950Ω {R _L max. = (V _s - 5) / 20 ⁻³ }
G	0.5 - 4.5V	+24V nom. (9 - 28V)	≥ 5kΩ
H	4 - 20mA 3 wire Source	+24V nom. (13 - 28V)	≈ 0 - 300Ω max. ~ 1.2 to 6V across 300Ω

Not all output options available - see product datasheet for full options list

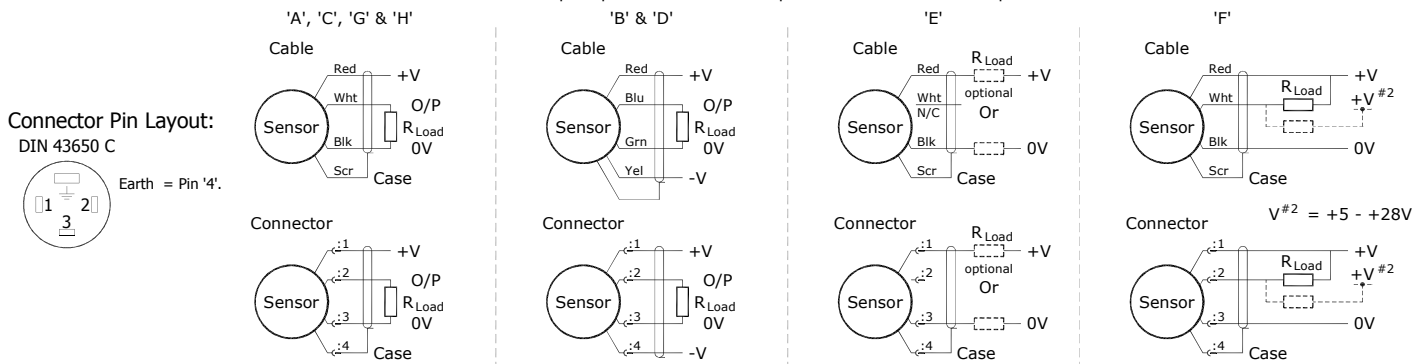

Gain and Offset Adjustment: (Where accessible - Typically ± 10% Min available)

To adjust the gain or offset use a small potentiometer adjuster or screwdriver 2mm across. Do not apply too much force on the potentiometers.

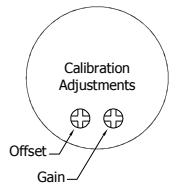

Mechanical Mounting: The sensor probe intended for internal mounting in hydraulic or pneumatic cylinders; retain with a grub screw and seal with 16x2.4 N70 O-ring provided. Install the target tube using the flange provided or adhere directly into the piston rod, the end of the target tube can be proud or flush with the piston end face as required. Mount electronics module externally on the cylinder via M18x1.5 thread or flange. The flange slots are 4.5 mm by 30 degrees wide on a 48 mm pitch. To protect against fluid ingress seal the grub screw retaining the probe, also fit a 16 x 2.4 mm O ring on the flanged version. The threaded version is fitted with bonded seal. Water around the probe connections will impair operation.

Probe Connections: The user to solder the probe wires to the rear of electronics unit; connect colours as shown right, note reference mark in flange base or etched on threaded base. Take care not to over twist wires installing the threaded version.

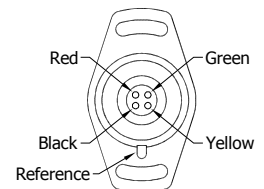

Output Characteristic: Target position at Start of normal travel is 4.5 mm from body face. The output increases as the target is moved away from the sensor body, the calibrated stroke is between 5 mm and 800 mm.

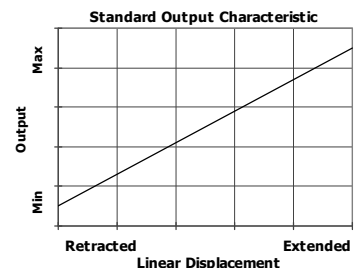

Installation Information

LIPS[®] P106 INTERNALLY MOUNTED CYLINDER SENSOR WITH EXTERNAL ELECTRONICS

Incorrect Connection Protection levels:-

- A **Not protected** – the sensor is **not** protected against either reverse polarity or over-voltage. The risk of damage should be minimal where the supply current is limited to less than 50mA.
- B & D Supply leads diode protected. Output must not be taken outside $\pm 12V$.
- C & G Supply leads diode protected. Output must not be taken outside 0 to 12V.
- E, F & H Protected against any misconnection within the rated voltage.