

STANDARD  
(CODE 'A')

DIRECTION OF SHAFT  
ROTATION FOR  
INCREASING OUTPUT.

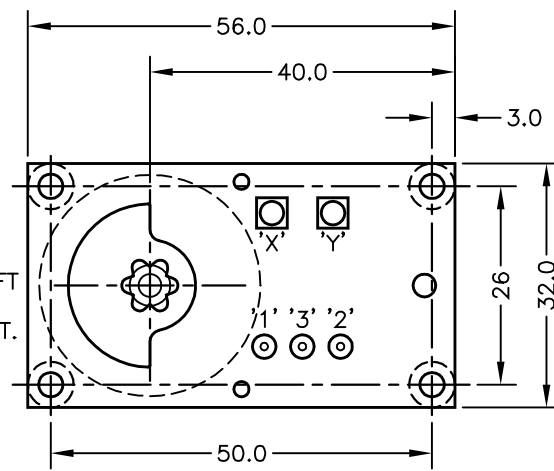

'X' GAIN ADJUSTMENT.  
'Y' OFFSET ADJUSTMENT.

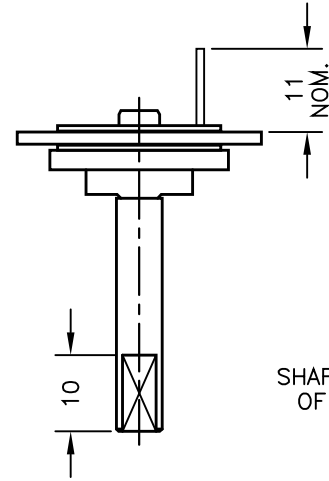

SHAFT SHOWN AT CENTRE  
OF CALIBRATED RANGE

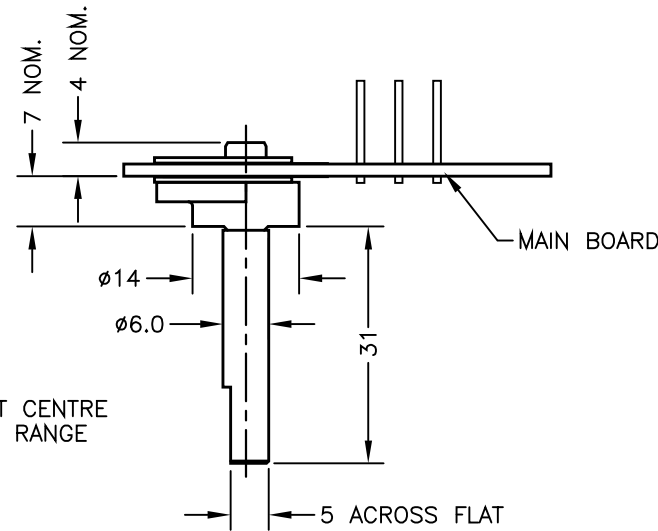

BUFFERED  
(CODES 'B' - 'H')

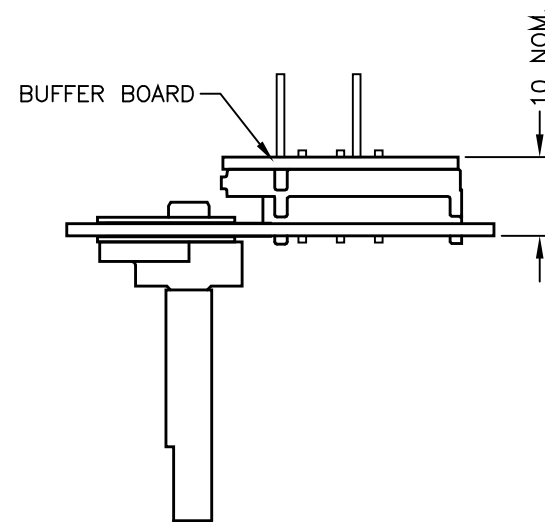
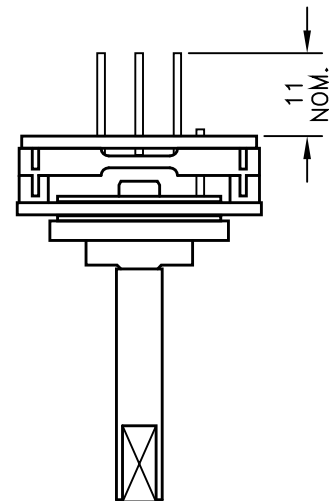
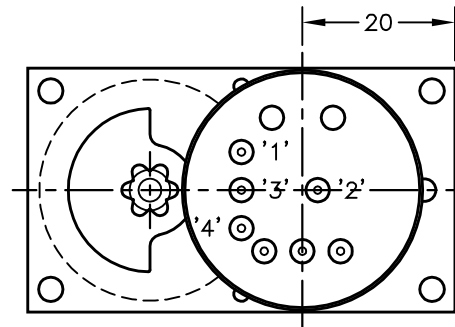

ELECTRICAL OPTIONS/ SPECIFICATIONS

OUTPUT OPTION	OUTPUT	SUPPLY	
A	0.5 TO 4.5V RATIO METRIC	5V	STANDARD
B	±5V	±15V	
C	0.5 TO 9.5V	24V	BUFFERED
D	±10V	±15V	
E	0.5 TO 4.5V	24V	
F	SUPPLY CURRENT 12mA TYP. 20mA MAX.	24V	
G	4 TO 20mA 2-WIRE	24V	
H	4 TO 20mA 3-WIRE SINK	24V	
	4 TO 20mA 3-WIRE SOURCE	24V	
	SINK VERSION OUTPUT COMPLIANCE 5-28V		
	SOURCE VERSION DRIVE 300Ω MAX TO 0V		

SOLDER PINS

- :1 +Ve
- :2 OUTPUT
- :3 0V
- :4 -Ve - OPTIONS: B OR D

RANGE OF DISPLACEMENT FROM 0-15° TO 0-160° e.g. 76°, IN INCREMENTS OF 1°.

SHAFT MATERIAL:- STAINLESS STEEL.  
PCB MATERIAL:- FR-4, 1.6mm THICK.

MOUNTING NOTES:

MAIN AND BUFFER CIRCUIT BOARDS ARE DOUBLE SIDED, ALLOW 3.5mm FROM BOARD SURFACES FOR COMPONENTS. 4 ø3.2 MOUNTING HOLES WITH ø6 CLEARANCE - BOTH SIDES. THE RADIAL POSITION OF THE SHAFT MUST BE CONTROLLED BY THE CUSTOMER.

THE END FLOAT OF THE SHAFT IS SET BY THE SENSOR AND SHOULD NOT BE CONTROLLED BY THE CUSTOMER.

H	REDRAWN, OPTIONS B & G ADDED.	PDM
I	HUB ROTATED 180 - RAN200	PDM
J	HUB ORIENTATION AS REV H - RAN257	PDM
K	PINS ADDED- RAN281	RDS
L	ADDITIONAL DIMS/VIEWS ADDED.	PDM
M	DISP. 15 TO 160° WAS 20 TO 160° RAN442.	PDM
N	RANGE NOTE AMENDED ~ RAN1200	PDM

DRAWINGS NOT TO BE CHANGED WITHOUT REFERENCE TO THE CHANGE PROCEDURE. CHANGES TO PARTS USED IN INTRINSICALLY SAFE PRODUCT MUST BE APPROVED BY THE AUTHORISED PERSON. THIS IS AN UNCONTROLLED PRINT AND WILL NOT BE UPDATED.

POSITEK  
**P**  
LIMITED

H	06/10/06		CHECKED BY	X	±0.4
I	18/02/08		RDS	X.X	±0.2
J	24/11/09			X.XX	±0.1
K	21/07/10				DIMS mm
L	06/07/11				
M	20/11/13				
N	12/09/17				
SCALE		DRAWING NUMBER		REV	
10mm		P503-11		N	
		SHEET		1 OF 1	