

LOAD CELL CHARACTERISTICS

US & S.I. CAPACITIES

#	CAPACITY	25, 50 (lbf) 100N & 200N	100, 125, 150 (lbf) 250N, 500N & 700N	250 (lbf) 1000N
1	COVER HEIGHT	0.80 [20.3]	0.70 [17.8]	0.80 [20.3]
2	OVERALL WIDTH	0.80 [20.3]	0.68 [17.2]	

Interface Inc. claims proprietary rights in the information disclosed herein. This drawing is furnished in confidence on the express understanding that neither it nor any reproduction thereof will be disclosed to others or used for the purpose of manufacture or procurement of the article or part shown hereon without written permission of Interface Inc. The drawing shall remain the property of Interface Inc. and shall be returned upon request by Interface Inc.

REVISIONS			
REV.	DESCRIPTION	DATE	APPROVED
A	REDRAWN, UPDATED TO CURRENT STANDARDS, 0.68 [17.2] WAS 0.76 [19.3], ADDED ADDITIONAL CAPACITIES	05/23/16	DLC
B	ADDED 700N CAPACITY	2/21/2017	BB

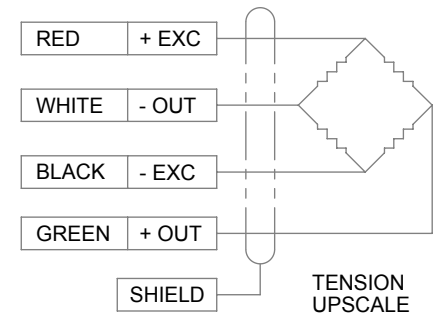
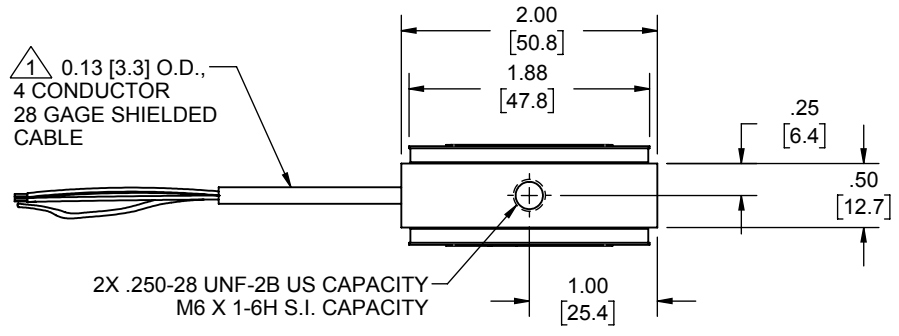

**TENSION LOAD
PRIMARY AXIS**

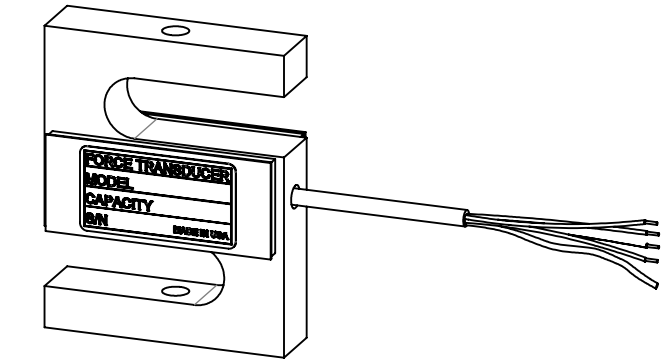
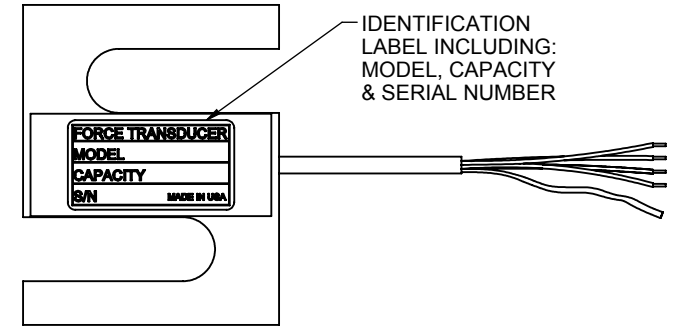
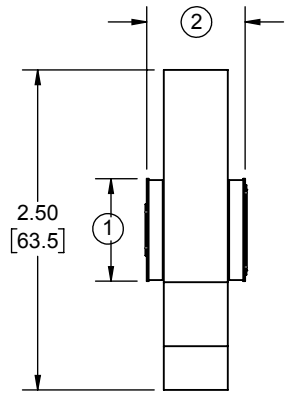
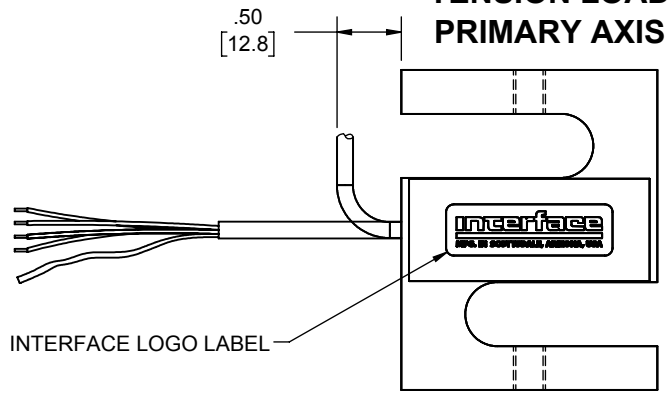

① STANDARD CABLE LENGTH IS 10 FT [3M]
NON-STANDARD CABLE LENGTH PER OPTION CODE.

UNLESS OTHERWISE SPECIFIED DIMENSIONS ARE IN INCHES [mm]	
TOLERANCES ARE:	
ANGLES ± 0° 30'	
.XX	± .01 [0.25]
.XXX	± .005 [0.13]
CREATOR:	DATE
DESIGNED:	
DETAILED:	01/02/1996
PER	
WEIGHT: (APPROX)	0.19 (lbs)

interface
ADVANCED FORCE MEASUREMENT
7401 E. BUTHERUS DR. SCOTTSDALE, AZ USA 85260

TITLE:
OUTLINE MODELS: SSM
-25 THRU -250, -100N THRU -1000N

SIZE: DWG. NO: **80031** REV: **B**

SCALE: 2:3 SHEET 1 OF 1

LOAD CELL CHARACTERISTICS

#	CAPACITY	US CAPACITIES	SI CAPACITIES
		500 (lbf)	2000 N
2	FLEXURE THREAD, TYP	.500-20 UNF-2B	M12 X 1.75-6H

Interface Inc. claims proprietary rights in the information disclosed herein. This drawing is furnished in confidence on the express understanding that neither it nor any reproduction thereof will be disclosed to others or used for the purpose of manufacture or procurement of the article or part shown hereon without written permission of Interface Inc. The drawing shall remain the property of Interface Inc. and shall be returned upon request by Interface Inc.

80045

REVISIONS

REV.	DESCRIPTION	DATE	APPROVED
A	CHANGED METRIC CONVERSION 13.5 TO 12.7	01/26/98	
B	REDRAWN, UPDATED TO CURRENT STANDARDS	05/24/16	DLC
C	ADDED TEDS PINOUT	09/07/2018	RMP

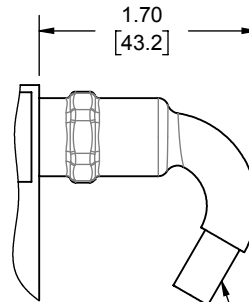
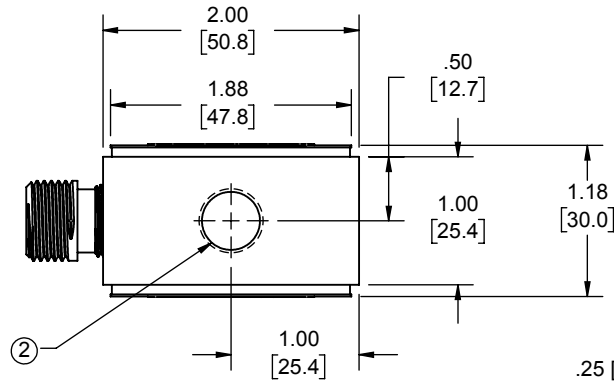

OPTIONAL

.25 [6.4] O.D. 4 CONDUCTOR
22 GAGE SHIELDED CABLE

CONNECTOR PINOUT		
PIN	W/O TEDS	WITH TEDS
A	+ EXCITATION	+ EXCITATION
B	+ SIGNAL	+ SIGNAL
C	- SIGNAL	- SIGNAL
D	- EXCITATION	- EXCITATION
E	N/C	TEDS DATA
F	N/C	TEDS GROUND

CABLE CONNECTIONS	
COLOR	FUNCTION
RED	+ EXCITATION
GREEN	+ SIGNAL
WHITE	- SIGNAL
BLACK	- EXCITATION
SHIELD	N/C

TENSION UPSCALE

ALL READ UPSCALE IN TENSION
AND DOWNSCALE IN COMPRESSION

INTERFACE
LOGO LABEL

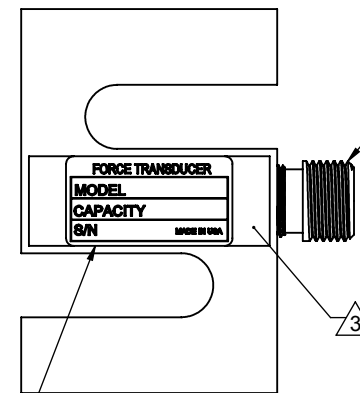
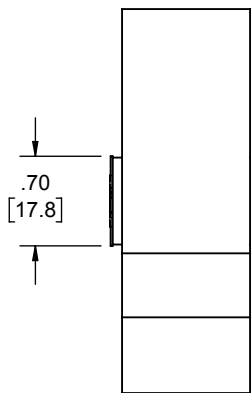
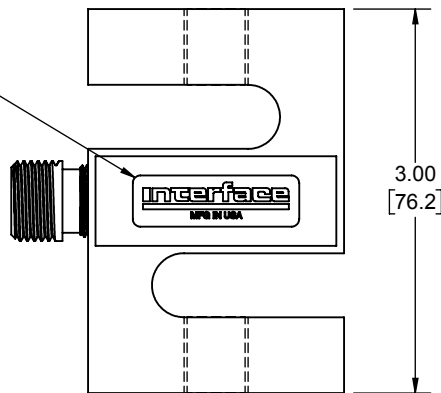

CONNECTOR:
PC04E-10-6P

IDENTIFICATION
LABEL INCLUDING:
MODEL, CAPACITY
& SERIAL NUMBER

4. MODELS WITH TEDS CHIP INSTALLED HAVE A "T"
AT THE END OF THE MODEL NUMBER (SSM-AF-500-T)

3 COVER COLOR: BLUE.

2. MATERIAL: ANODIZED ALUMINUM.

1 STANDARD CABLE LENGTH IS 10 FT [3M]
NON-STANDARD CABLE LENGTH PER OPTION CODE.

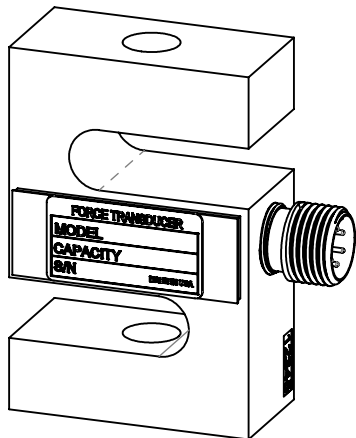

UNLESS OTHERWISE SPECIFIED
DIMENSIONS ARE IN INCHES [mm]
TOLERANCES ARE:
ANGLES ± 0° 30'
.XX ± .01 [0.25]
.XXX ± .005 [0.13]

CREATOR	DATE
DESIGNED:	
DETAILED: PER	1/2/1996
WEIGHT: (APPROX) 0.43 (lbs)	

Interface
FORCE MEASUREMENT SOLUTIONS. 7418 E. HELM DRIVE
SCOTTSDALE, AZ 85260 USA

TITLE:
**OUTLINE MODELS:
SSM-500 & 2000N**

SIZE: A	DWG. NO: 80045	REV: C
SCALE: 2:3	SHEET 1 OF 1	

LOAD CELL CHARACTERISTICS

#	CAPACITY	US CAPACITIES		SI CAPACITIES	
		750, 1K (lbf)	2K, 3K (lbf)	2.5kN, 3kN, 5kN	10kN
1	FLEXURE MATERIAL	②	③	②	③
2	FLEXURE THREAD, TYP	.500-20 UNF-2B		M12 X 1.75-6H	
3	FLEXURE LENGTH	2.00	1.98	2.00	1.98
4	FLEXURE WIDTH	1.00	0.98	1.00	0.98
5	O/L WIDTH	1.25	1.23	1.25	1.23
6	FLEXURE HEIGHT	3.00	2.98	3.00	2.98
	WEIGHT (lbs)	0.50	1.30	0.50	1.30

Interface Inc. claims proprietary rights in the information disclosed herein. This drawing is furnished in confidence on the express understanding that neither it nor any reproduction thereof will be disclosed to others or used for the purpose of manufacture or procurement of the article or part shown herein without written permission of Interface Inc. The drawing shall remain the property of Interface Inc. and shall be returned upon request by Interface Inc.

REVISIONS			
REV.	DESCRIPTION	DATE	APPROVED
	INITIAL RELEASE	01/02/96	
A	REDRAWN, UPDATED TO CURRENT STANDARDS, 1.19 [30.1] WAS 1.25 [31.8]	05/24/16	DLC
B	ADDED LINES 3 - 6 & WEIGHT TO TABLE	7/26/2019	RMP

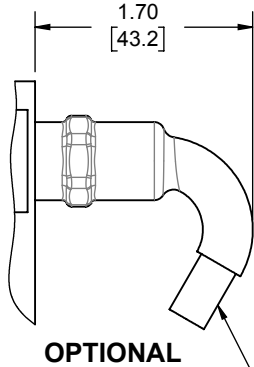

CONNECTOR PINOUT	
PIN	FUNCTION
A	+ EXCITATION
B	+ SIGNAL
C	- SIGNAL
D	- EXCITATION
E	N/C
F	N/C

CABLE CONNECTIONS	
COLOR	FUNCTION
RED	+ EXCITATION
GREEN	+ SIGNAL
WHITE	- SIGNAL
BLACK	- EXCITATION
SHIELD	N/C

ALL READ UPSCALE IN TENSION AND DOWNSCALE IN COMPRESSION

.25 [6.4] O.D. 4 CONDUCTOR ①
22 GAGE SHIELDED CABLE

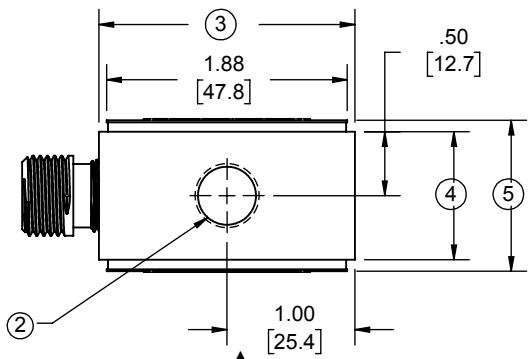

**TENSION LOAD
PRIMARY AXIS**

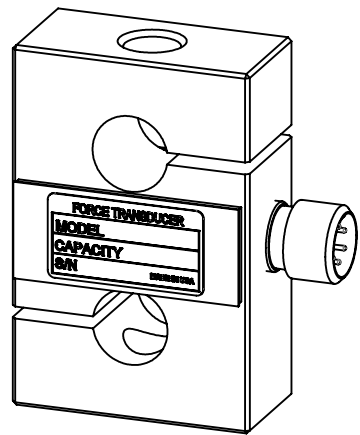
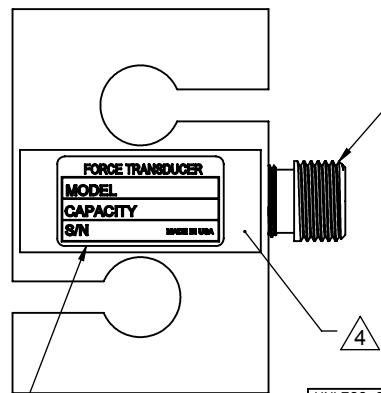
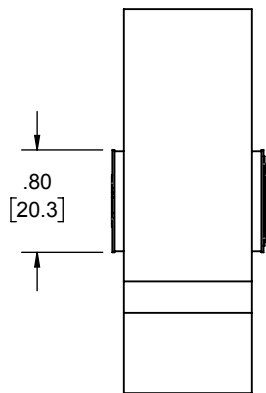
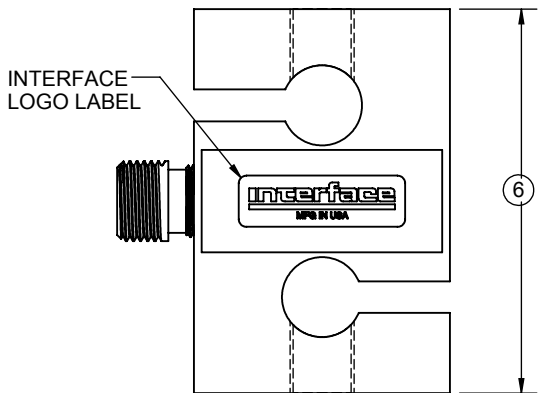

IDENTIFICATION LABEL INCLUDING:
MODEL, CAPACITY & SERIAL NUMBER

- ④ COVER COLOR: BLUE.
- ③ MATERIAL: NICKEL PLATED STEEL.
- ② MATERIAL: ANODIZED ALUMINUM.
- ① STANDARD CABLE LENGTH IS 10 FT [3M]
NON-STANDARD CABLE LENGTH PER OPTION CODE.

UNLESS OTHERWISE SPECIFIED DIMENSIONS ARE IN INCHES [mm]	
TOLERANCES ARE:	
ANGLES ± 0° 30'	
.XX ± .01 [0.25]	
.XXX ± .005 [0.13]	
CREATOR	DATE
DESIGNED:	
DETAILED:	1/2/1996
PER	
WEIGHT: (APPROX)	0.49 (lbs)

Interface 7418 E. HELM DRIVE
FORCE MEASUREMENT SOLUTIONS, SCOTTSDALE, AZ 85260 USA

TITLE:
OUTLINE MODELS: SSM-750 THRU 3K, 5KN THRU 10KN

SIZE: DWG. NO: **80032** REV: **B**

SCALE: 2:3 SHEET 1 OF 1

80033

LOAD CELL CHARACTERISTICS

#	CAPACITY	US CAPACITIES	SI CAPACITIES
		2.5K, 5K (lbf)	15, 20 (kN)
1	FLEXURE THREAD, TYP	.625-18 UNF-2B	M16 X 2-6H

Interface Inc. claims proprietary rights in the information disclosed herein. This drawing is furnished in confidence on the express understanding that neither it nor any reproduction thereof will be disclosed to others or used for the purpose of manufacture or procurement of the article or part shown hereon without written permission of Interface Inc. The drawing shall remain the property of Interface Inc. and shall be returned upon request by Interface Inc.

REVISIONS			
REV.	DESCRIPTION	DATE	APPROVED
-	INITIAL RELEASE	01/02/96	
A	REDRAWN, UPDATED TO CURRENT STANDARDS	09/28/2016	DLC
B	SI CAPACITY 15, 20 (kN) WAS 10, 20 (kN)	2/23/2017	DLC
C	REPLACED COVER WITH -7 VERSION (2.38 WAS 1.88; .84 WAS .80; 1.76 WAS 1.73)	3/20/2017	BB

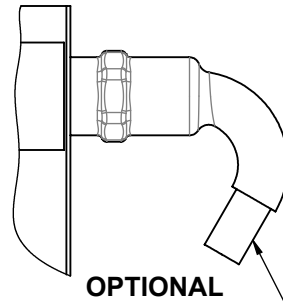
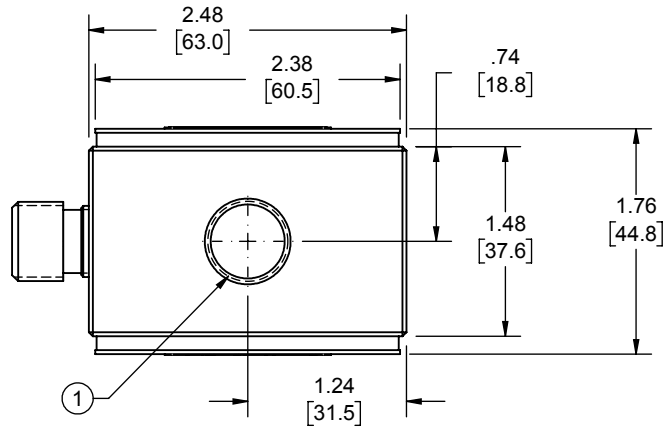

CONNECTOR PINOUT	
PIN	FUNCTION
A	+ EXCITATION
B	+ OUTPUT
C	- OUTPUT
D	- EXCITATION
E	N/C
F	N/C

CABLE CONNECTIONS	
COLOR	FUNCTION
RED	+ EXCITATION
GREEN	+ OUTPUT
WHITE	- OUTPUT
BLACK	- EXCITATION
SHIELD	N/C

TENSION UPSCALE

.25 [6.4] O.D. 4 CONDUCTOR ¹/₂ 22 GAGE SHIELDED CABLE

TENSION LOAD PRIMARY AXIS

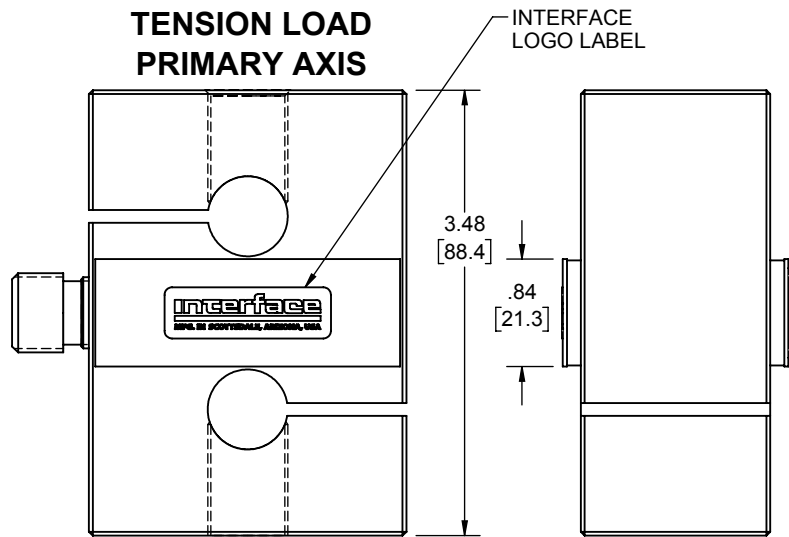

CONNECTOR: PC04E-10-6P

PIN A

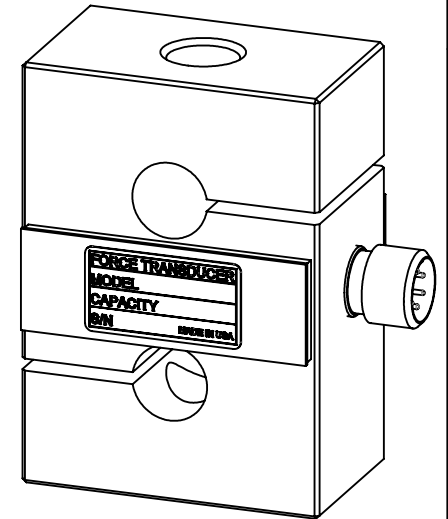
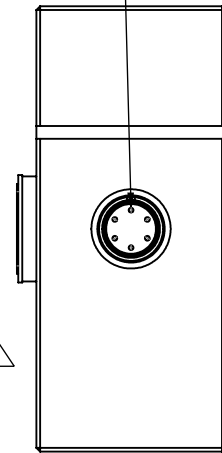
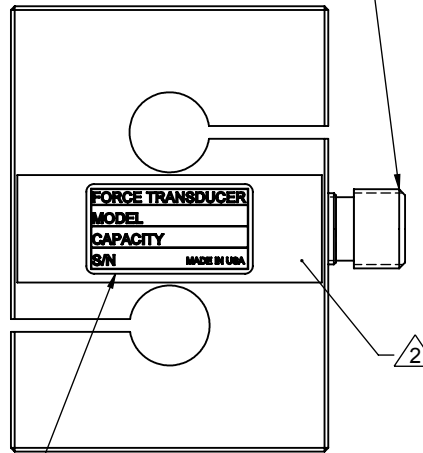

IDENTIFICATION LABEL INCLUDING: MODEL, CAPACITY & SERIAL NUMBER

²/₂ COVER COLOR: BLUE.

¹/₁ STANDARD CABLE LENGTH IS 10 FT [3M] NON-STANDARD CABLE LENGTH PER OPTION CODE.

UNLESS OTHERWISE SPECIFIED DIMENSIONS ARE IN INCHES [mm] TOLERANCES ARE: ANGLES ± 0° 30' .XX ± .01 [0.25] .XXX ± .005 [0.13]

interface
ADVANCED FORCE MEASUREMENT
7401 E. BUTHERUS DR. SCOTTSDALE, AZ USA 85260

TITLE: OUTLINE MODEL: SSM-5000 & 20KN

CREATOR	DATE
DESIGNED:	
DETAILED: PER	01/02/1996
WEIGHT: (APPROX)	

SIZE: A	DWG. NO: 80033	REV: C
SCALE: 2:3	SHEET 1 OF 1	

LOAD CELL CHARACTERISTICS			
#	CAPACITY	US CAPACITIES	S.I. CAPACITIES
		5000, 10K (lbf)	25, 50 (kN)
①	FLEXURE THREAD (BOTH ENDS)	.75-16 UNF-2B ∇ .75	M20 X 1.5-6H ∇ (18.5)

Interface Inc. claims proprietary rights in the information disclosed herein. This drawing is furnished in confidence on the express understanding that neither it nor any reproduction thereof will be disclosed to others or used for the purpose of manufacture or procurement of the article or part shown herein without written permission of Interface Inc. The drawing shall remain the property of Interface Inc. and shall be returned upon request by Interface Inc.

81222			
REVISIONS			
REV.	DESCRIPTION	DATE	APPROVED
A	INITIAL RELEASE	01/14/13	
B	ADDED TABLE FOR METRIC MODELS	11/14/13	<i>Ma</i>
C	UPDATED TO CURRENT STANDARDS	3/30/2017	BB

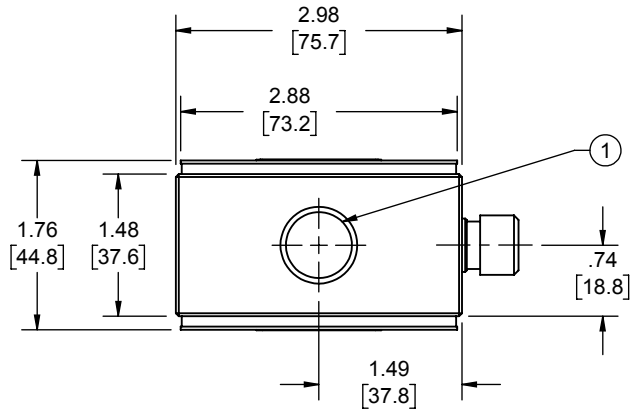

INTEGRAL CABLE MODELS \triangle 2

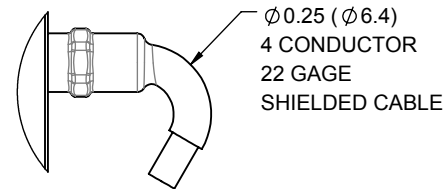

CABLE CONNECTION	
COLOR	FUNCTION
RED	+ EXCITATION
GREEN	+ SIGNAL
WHITE	- SIGNAL
BLACK	- EXCITATION
SHIELD	N / C
TENSION UPSCALE	

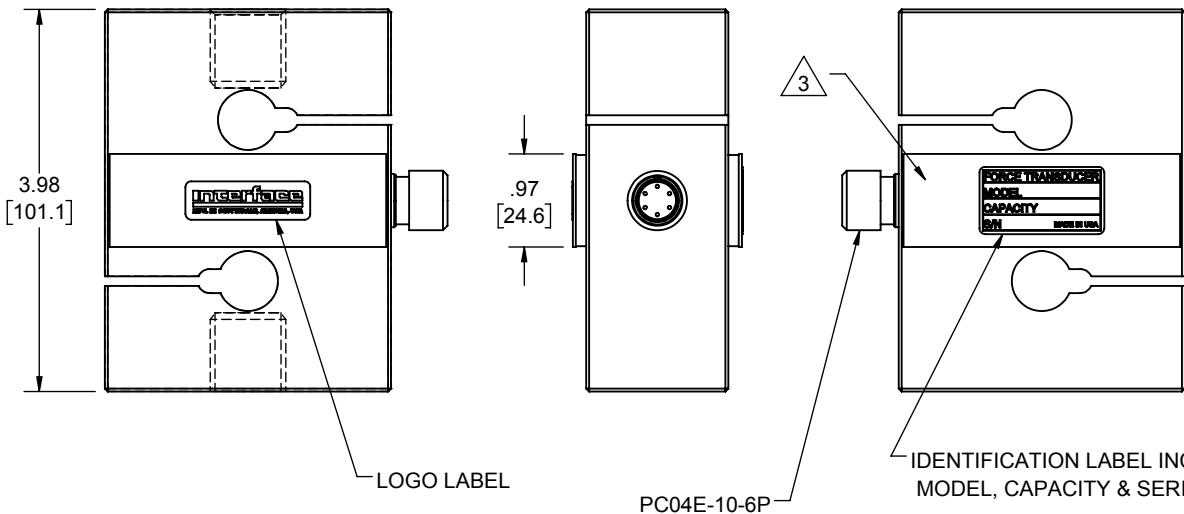

CONNECTOR MODELS

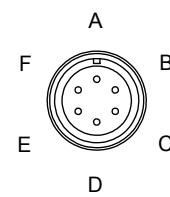

CONNECTOR PINOUT	
PIN	FUNCTION
A	+ EXCITATION
B	+ SIGNAL
C	- SIGNAL
D	- EXCITATION
E	N / C
F	N / C
TENSION UPSCALE	

\triangle 3 COVER COLOR: BLUE.

\triangle 2 STANDARD CABLE LENGTH: 10 FEET (3 METERS).
NON-STANDARD CABLE LENGTH PER OPTION CODE.

1. FLEXURE MATERIAL: STEEL, NICKEL PLATED.

UNLESS OTHERWISE SPECIFIED DIMENSIONS ARE IN INCHES [mm] TOLERANCES ARE: ANGLES $\pm 0^\circ 30'$.XX $\pm .01$ [0.25] .XXX $\pm .005$ [0.13]		interface ADVANCED FORCE MEASUREMENT 7401 E. BUTHERUS DR. SCOTTSDALE, AZ USA 85260	
CREATOR	DATE	TITLE: OUTLINE, MODEL SSM2	
DESIGNED: LARRY B.	01/07/2013	SIZE: A	DWG. NO: 81222
DETAILED: J.A.S.	01/07/2013	SCALE: 1:2	SHEET 1 OF 1
WEIGHT: (APPROX) 4.5 (lbs)			REV: C