

Vergleichstabelle 6-Achsen Sensoren / Comparison table for 6-axis sensors

	Technische Daten / <i>technical data</i>	Einheit / <i>unit</i>	F6D45 20N/1Nm	F6D80-40 100N/10Nm	F6D80-40 300N/30Nm
Sensortyp / sensor type	Bauform / <i>design</i>		Robotik Flansch / <i>robotics flange</i> FT Sensor	Robotik Flansch/ <i>robotics flange</i> FT Sensor	Robotik Flansch / <i>robotics flange</i> FT Sensor
	Messprinzip / <i>measuring principle</i>		6x DMS Vollbrücke / 6x <i>strain gauge full bridge</i>	6x DMS Vollbrücke / 6x <i>strain gauge full bridge</i>	6x DMS-Vollbrücke / 6x <i>strain gauge full bridge</i>
	Konstruktion / <i>construction</i>		3x Biegering / <i>bending element</i>	3x Biegering / <i>bending element</i>	3x Biegering / <i>bending element</i>
	Material / <i>material</i>		Al Legierung / <i>al alloy</i>	Al Legierung / <i>al alloy</i>	Stahl / <i>steel</i> , 1.4542
	Gewicht / <i>weight</i>	kg			
Abmessungen / dimensions	Durchmesser / <i>diameter</i>	mm	45	80	80
	Höhe / <i>height</i>	mm	26	40	40
	Teilkreis / <i>pitch circle</i>	mm	20	40	40
Mechanische Daten / mechanical data	Nennkraft / <i>rated force</i> Fx	N	20	100	300
	Nennkraft / <i>rated force</i> Fy	N	20	100	300
	Nennkraft / <i>rated force</i> Fz	N	50	200	600
	Nennmoment / <i>rated torque</i> Mx	Nm	1	10	30
	Nennmoment / <i>rated torque</i> My	Nm	1	10	30
	Nennmoment / <i>rated torque</i> Mz	Nm	1	10	30
	Gebrauchskraft / <i>operating force</i> Fx	N	60	900	2100
	Gebrauchskraft / <i>operating force</i> Fy	N	60	900	2100
	Gebrauchskraft / <i>operating force</i> Fz	N	150	3000	5400
	Grenzbiegemoment / <i>bending moment limit</i> Mx	Nm	1,5	60	150
Grenzbiegemoment / <i>bending moment limit</i> My	Nm	1,5	60	150	
Grenzdrehmoment / <i>bending moment limit</i> Mz	Nm	1,5	30	90	

Vergleichstabelle 6-Achsen Sensoren / Comparison table for 6-axis sensors

	Technische Daten / <i>technical data</i>	Einheit / <i>unit</i>	F6D45 20N/1Nm	F6D80-40 100N/10Nm	F6D80-40 300N/30Nm	
Elektrische Daten / <i>electrical data</i>	Nennkennwert / <i>rated characteristic value</i> Fx	mV/V	0,5	0,23	0,3	
	Nennkennwert / <i>rated characteristic value</i> Fy	mV/V	0,5	0,23	0,3	
	Nennkennwert / <i>rated characteristic value</i> Fz	mV/V	0,8	0,13	0,22	
	Nennkennwert / <i>rated characteristic value</i> Mx	mV/V	1,5	0,35	0,4	
	Nennkennwert / <i>rated characteristic value</i> My	mV/V	1,5	0,35	0,4	
	Nennkennwert / <i>rated characteristic value</i> Mz	mV/V	1,5	0,68	0,7	
	kleinster Anzeigeschritt mit GSV-1, GSV-6 (Rauschamplitude) / <i>smallest display step with „GSV-1, GSV-6“ (noise amplitude)</i>					
	Auflösung / <i>resolution</i> Fx	N	0,0080	0,0870	0,2000	
	Auflösung / <i>resolution</i> Fy	N	0,0080	0,0870	0,2000	
	Auflösung / <i>resolution</i> Fz	N	0,0125	0,3077	0,5455	
	Auflösung / <i>resolution</i> Mx	Nm	0,0001	0,0057	0,0150	
	Auflösung / <i>resolution</i> My	Nm	0,0001	0,0057	0,0150	
	Auflösung / <i>resolution</i> Mz	Nm	0,0001	0,0029	0,0086	
	kleinster Anzeigeschritt mit GSV-8 (Rauschamplitude) / <i>smallest display step with GSV-8 (noise amplitude)</i>					
	Auflösung / <i>resolution</i> Fx	N	0,0016	0,0174	0,0400	
	Auflösung / <i>resolution</i> Fy	N	0,0016	0,0174	0,0400	
	Auflösung / <i>resolution</i> Fz	N	0,0025	0,0615	0,1091	
	Auflösung / <i>resolution</i> Mx	Nm	0,00003	0,0011	0,0030	
	Auflösung / <i>resolution</i> My	Nm	0,00003	0,0011	0,0030	
	Auflösung / <i>resolution</i> Mz	Nm	0,00003	0,0006	0,0017	
	Merkmal / <i>characteristics</i>	Ursprung / <i>origin</i>		B	B	B
Anschluss / <i>connection</i>			CG	CG; MP11; M12	CG; MP11; M12	

Vergleichstabelle 6-Achsen Sensoren / Comparison table for 6-axis sensors

	Technische Daten / <i>technical data</i>	Einheit / <i>unit</i>	F6D100-50 200N/20Nm	F6D100-50 600N/60Nm	K6D27 50N/1Nm	K6D40 50N/5Nm
Sensortyp / sensor type	Bauform / <i>design</i>		Robotik Flansch/ <i>robotics flange</i> FT Sensor	Robotik Flansch/ <i>robotics flange</i> FT Sensor	Miniatur / <i>miniature</i> FT Sensor	FT Sensor
	Messprinzip / <i>measuring principle</i>		6x DMS Vollbrücke / <i>6x strain gauge full bridge</i>	6x DMS-Vollbrücke / <i>6x strain gauge full bridge</i>	6x DMS Vollbrücke / <i>6x strain gauge full bridge</i>	6x DMS Vollbrücke / <i>6x strain gauge full bridge</i>
	Konstruktion / <i>construction</i>		3x Biegering / <i>bending element</i>	3x Biegering / <i>bending element</i>	6x Druckstab / <i>pillar</i>	6x Druckstab / <i>pillar</i>
	Material / <i>material</i>		Al Legierung / <i>al alloy</i>	Stahl / <i>steel</i> , 1.4542	Al Legierung / <i>al alloy</i>	Al Legierung / <i>al alloy</i>
	Gewicht / <i>weight</i>	kg		1,070	0,030	0,160
Abmessungen / dimensions	Durchmesser / <i>diameter</i>	mm	100	100	27	60
	Höhe / <i>height</i>	mm	40	40	25	40
	Teilkreis / <i>pitch circle</i>	mm	50	50	20	47
Mechanische Daten / mechanical data	Nennkraft / <i>rated force</i> Fx	N	200	600	50	50
	Nennkraft / <i>rated force</i> Fy	N	200	600	50	50
	Nennkraft / <i>rated force</i> Fz	N	400	1200	200	200
	Nennmoment / <i>rated torque</i> Mx	Nm	20	60	1	5
	Nennmoment / <i>rated torque</i> My	Nm	20	60	1	5
	Nennmoment / <i>rated torque</i> Mz	Nm	20	60	1	5
	Gebrauchskraft / <i>operating force</i> Fx	N	600	1800	150	200
	Gebrauchskraft / <i>operating force</i> Fy	N	600	1800	150	200
	Gebrauchskraft / <i>operating force</i> Fz	N	2400	9600	600	800
	Grenzbiegemoment / <i>bending moment limit</i> Mx	Nm	200	180	3	20
Grenzbiegemoment / <i>bending moment limit</i> My	Nm	200	180	3	20	
Grenzdrehmoment / <i>bending moment limit</i> Mz	Nm	100	120	3	30	

Vergleichstabelle 6-Achsen Sensoren / Comparison table for 6-axis sensors

	Technische Daten / <i>technical data</i>	Einheit / <i>unit</i>	F6D100-50 200N/20Nm	F6D100-50 600N/60Nm	K6D27 50N/1Nm	K6D40 50N/5Nm	
Elektrische Daten / <i>electrical data</i>	Nennkennwert / <i>rated characteristic value</i> Fx	mV/V	0,75	0,6	0,6	0,2	
	Nennkennwert / <i>rated characteristic value</i> Fy	mV/V	0,75	0,6	0,6	0,2	
	Nennkennwert / <i>rated characteristic value</i> Fz	mV/V	0,33	0,25	0,8	0,2	
	Nennkennwert / <i>rated characteristic value</i> Mx	mV/V	0,2	0,68	0,7	0,3	
	Nennkennwert / <i>rated characteristic value</i> My	mV/V	0,2	0,68	0,7	0,3	
	Nennkennwert / <i>rated characteristic value</i> Mz	mV/V	0,4	0,9	0,6	0,4	
	kleinster Anzeigeschritt mit GSV-1, GSV-6 (Rauschamplitude) / <i>smallest display step with „GSV-1, GSV-6“ (noise amplitude)</i>						
	Auflösung / <i>resolution</i> Fx	N	0,0533	0,2000	0,0167	0,0500	
	Auflösung / <i>resolution</i> Fy	N	0,0533	0,2000	0,0167	0,0500	
	Auflösung / <i>resolution</i> Fz	N	0,2424	0,9600	0,0500	0,2000	
	Auflösung / <i>resolution</i> Mx	Nm	0,0200	0,0176	0,0003	0,0033	
	Auflösung / <i>resolution</i> My	Nm	0,0200	0,0176	0,0003	0,0033	
	Auflösung / <i>resolution</i> Mz	Nm	0,0100	0,0133	0,0003	0,0025	
	kleinster Anzeigeschritt mit GSV-8 (Rauschamplitude) / <i>smallest display step with GSV-8 (noise amplitude)</i>						
	Auflösung / <i>resolution</i> Fx	N	0,0107	0,0400	0,0033	0,0100	
	Auflösung / <i>resolution</i> Fy	N	0,0107	0,0400	0,0033	0,0100	
	Auflösung / <i>resolution</i> Fz	N	0,0485	0,1920	0,0100	0,0400	
	Auflösung / <i>resolution</i> Mx	Nm	0,0040	0,0035	0,0001	0,0007	
	Auflösung / <i>resolution</i> My	Nm	0,0040	0,0035	0,0001	0,0007	
	Auflösung / <i>resolution</i> Mz	Nm	0,0020	0,0027	0,0001	0,0005	
Merkmal / <i>characteristics</i>	Ursprung / <i>origin</i>		B	B	B	B	
	Anschluss / <i>connection</i>		CG; MP11; M12	CG; MP11; M12	CG	MP11, CG	

Vergleichstabelle 6-Achsen Sensoren / Comparison table for 6-axis sensors

	Technische Daten / <i>technical data</i>	Einheit / <i>unit</i>	K6D40 200N/5Nm	K6D40 500N/20Nm	K6D68 1kN/20Nm	K6D68 2kN/50Nm
Sensortyp / sensor type	Bauform / <i>design</i>		FT Sensor	FT Sensor	FT Sensor	FT Sensor
	Messprinzip / <i>measuring principle</i>		6x DMS Vollbrücke / 6x strain gauge full bridge	6x DMS Vollbrücke / 6x strain gauge full bridge	6x DMS Vollbrücke / 6x strain gauge full bridge	6x DMS Vollbrücke / 6x strain gauge full bridge
	Konstruktion / <i>construction</i>		6x Druckstab / <i>pillar</i>	6x Druckstab / <i>pillar</i>	6x Druckstab / <i>pillar</i>	6x Druckstab / <i>pillar</i>
	Material / <i>material</i>		Al Legierung / <i>al alloy</i>	Stahl / <i>steel</i> , 1.4542	Al Legierung / <i>al alloy</i>	Stahl / <i>steel</i> , 1.4542
	Gewicht / <i>weight</i>	kg	0,190	0,360	0,550	1,050
Abmessungen / dimensions	Durchmesser / <i>diameter</i>	mm	60	60	83	83
	Höhe / <i>height</i>	mm	40	40	64	64
	Teilkreis / <i>pitch circle</i>	mm	47	47	65	65
Mechanische Daten / mechanical data	Nennkraft / <i>rated force</i> Fx	N	200	500	1000	2000
	Nennkraft / <i>rated force</i> Fy	N	200	500	1000	2000
	Nennkraft / <i>rated force</i> Fz	N	500	2000	2000	4000
	Nennmoment / <i>rated torque</i> Mx	Nm	5	20	20	50
	Nennmoment / <i>rated torque</i> My	Nm	5	20	20	50
	Nennmoment / <i>rated torque</i> Mz	Nm	10	40	20	50
	Gebrauchskraft / <i>operating force</i> Fx	N	800	2000	3000	8000
	Gebrauchskraft / <i>operating force</i> Fy	N	800	2000	3000	8000
	Gebrauchskraft / <i>operating force</i> Fz	N	2000	8000	10000	20000
	Grenzbiegemoment / <i>bending moment limit</i> Mx	Nm	20	80	140	250
Grenzbiegemoment / <i>bending moment limit</i> My	Nm	20	80	140	250	
Grenzdrehmoment / <i>bending moment limit</i> Mz	Nm	30	120	140	300	

Vergleichstabelle 6-Achsen Sensoren / Comparison table for 6-axis sensors

	Technische Daten / <i>technical data</i>	Einheit / <i>unit</i>	K6D40 200N/5Nm	K6D40 500N/20Nm	K6D68 1kN/20Nm	K6D68 2kN/50Nm	
Elektrische Daten / <i>electrical data</i>	Nennkennwert / <i>rated characteristic value</i> Fx	mV/V	0,4	0,33	0,6	0,56	
	Nennkennwert / <i>rated characteristic value</i> Fy	mV/V	0,4	0,33	0,6	0,56	
	Nennkennwert / <i>rated characteristic value</i> Fz	mV/V	0,4	0,45	0,43	0,38	
	Nennkennwert / <i>rated characteristic value</i> Mx	mV/V	0,3	0,39	0,3	0,37	
	Nennkennwert / <i>rated characteristic value</i> My	mV/V	0,3	0,39	0,3	0,37	
	Nennkennwert / <i>rated characteristic value</i> Mz	mV/V	0,4	0,62	0,3	0,32	
	kleinster Anzeigeschritt mit GSV-1, GSV-6 (Rauschamplitude) / <i>smallest display step with „GSV-1, GSV-6“ (noise amplitude)</i>						
	Auflösung / <i>resolution</i> Fx	N	0,1000	0,3030	0,3333	0,7143	
	Auflösung / <i>resolution</i> Fy	N	0,1000	0,3030	0,3333	0,7143	
	Auflösung / <i>resolution</i> Fz	N	0,2500	0,8889	0,9302	2,1053	
	Auflösung / <i>resolution</i> Mx	Nm	0,0033	0,0103	0,0133	0,0270	
	Auflösung / <i>resolution</i> My	Nm	0,0033	0,0103	0,0133	0,0270	
	Auflösung / <i>resolution</i> Mz	Nm	0,0050	0,0129	0,0133	0,0313	
	kleinster Anzeigeschritt mit GSV-8 (Rauschamplitude) / <i>smallest display step with GSV-8 (noise amplitude)</i>						
	Auflösung / <i>resolution</i> Fx	N	0,0200	0,0606	0,0667	0,1429	
	Auflösung / <i>resolution</i> Fy	N	0,0200	0,0606	0,0667	0,1429	
	Auflösung / <i>resolution</i> Fz	N	0,0500	0,1778	0,1860	0,4211	
	Auflösung / <i>resolution</i> Mx	Nm	0,0007	0,0021	0,0027	0,0054	
	Auflösung / <i>resolution</i> My	Nm	0,0007	0,0021	0,0027	0,0054	
	Auflösung / <i>resolution</i> Mz	Nm	0,0010	0,0026	0,0027	0,0063	
	Merkmal / <i>characteristics</i>	Ursprung / <i>origin</i>		B	B	B	B
Anschluss / <i>connection</i>			CG	CG	CG	CG	

Vergleichstabelle 6-Achsen Sensoren / Comparison table for 6-axis sensors

	Technische Daten / <i>technical data</i>	Einheit / <i>unit</i>	K6D68 5kN/50Nm	K6D68 10kN/100Nm	K6D68 10kN/500Nm	K6D80 500N/20Nm
Sensortyp / sensor type	Bauform / <i>design</i>		FT Sensor	FT Sensor	FT Sensor	FT Sensor
	Messprinzip / <i>measuring principle</i>		6x DMS Vollbrücke / 6x strain gauge full bridge	6x DMS Vollbrücke / 6x strain gauge full bridge	6x DMS Vollbrücke / 6x strain gauge full bridge	6x DMS Vollbrücke / 6x strain gauge full bridge
	Konstruktion / <i>construction</i>		6x Druckstab / <i>pillar</i>	6x Druckstab / <i>pillar</i>	6x Druckstab / <i>pillar</i>	6x Druckstab / <i>pillar</i>
	Material / <i>material</i>		Stahl / <i>steel</i> , 1.4542	Stahl / <i>steel</i> , 1.4542	Stahl / <i>steel</i> , 1.4542	AL Legierung / <i>al alloy</i>
	Gewicht / <i>weight</i>	kg	1,050	1,050	1,050	0,800
Abmessungen / dimensions	Durchmesser / <i>diameter</i>	mm	83	83	83	80
	Höhe / <i>height</i>	mm	64	64	64	50
	Teilkreis / <i>pitch circle</i>	mm	65	65	65	60
Mechanische Daten / mechanical data	Nennkraft / <i>rated force</i> Fx	N	5000	10000	10000	500
	Nennkraft / <i>rated force</i> Fy	N	5000	10000	10000	500
	Nennkraft / <i>rated force</i> Fz	N	10000	10000	10000	1000
	Nennmoment / <i>rated torque</i> Mx	Nm	50	100	500	20
	Nennmoment / <i>rated torque</i> My	Nm	50	100	500	20
	Nennmoment / <i>rated torque</i> Mz	Nm	50	100	500	20
	Gebrauchskraft / <i>operating force</i> Fx	N	10000	20000	40000	1500
	Gebrauchskraft / <i>operating force</i> Fy	N	10000	20000	40000	1500
	Gebrauchskraft / <i>operating force</i> Fz	N	50000	50000	100000	3000
	Grenzbiegemoment / <i>bending moment limit</i> Mx	Nm	400	700	1500	60
Grenzbiegemoment / <i>bending moment limit</i> My	Nm	400	700	1500	60	
Grenzdrehmoment / <i>bending moment limit</i> Mz	Nm	450	800	1500	60	

Vergleichstabelle 6-Achsen Sensoren / Comparison table for 6-axis sensors

	Technische Daten / <i>technical data</i>	Einheit / <i>unit</i>	K6D68 5kN/50Nm	K6D68 10kN/100Nm	K6D68 10kN/500Nm	K6D80 500N/20Nm	
Elektrische Daten / <i>electrical data</i>	Nennkennwert / <i>rated characteristic value</i> Fx	mV/V	1	1	0,5	0,7	
	Nennkennwert / <i>rated characteristic value</i> Fy	mV/V	1	1	0,5	0,7	
	Nennkennwert / <i>rated characteristic value</i> Fz	mV/V	0,39	0,39	0,2	0,5	
	Nennkennwert / <i>rated characteristic value</i> Mx	mV/V	0,26	0,3	0,8	0,7	
	Nennkennwert / <i>rated characteristic value</i> My	mV/V	0,26	0,3	0,8	0,7	
	Nennkennwert / <i>rated characteristic value</i> Mz	mV/V	0,23	0,25	0,8	0,7	
	kleinster Anzeigeschritt mit GSV-1, GSV-6 (Rauschamplitude) / <i>smallest display step with „GSV-1, GSV-6“ (noise amplitude)</i>						
	Auflösung / <i>resolution</i> Fx	N	1,0000	2,0000	4,0000	0,1429	
	Auflösung / <i>resolution</i> Fy	N	1,0000	2,0000	4,0000	0,1429	
	Auflösung / <i>resolution</i> Fz	N	5,1282	5,1282	10,0000	0,4000	
	Auflösung / <i>resolution</i> Mx	Nm	0,0385	0,0667	0,1250	0,0057	
	Auflösung / <i>resolution</i> My	Nm	0,0385	0,0667	0,1250	0,0057	
	Auflösung / <i>resolution</i> Mz	Nm	0,0435	0,0800	0,1250	0,0057	
	kleinster Anzeigeschritt mit GSV-8 (Rauschamplitude) / <i>smallest display step with GSV-8 (noise amplitude)</i>						
	Auflösung / <i>resolution</i> Fx	N	0,2000	0,4000	0,8000	0,0286	
	Auflösung / <i>resolution</i> Fy	N	0,2000	0,4000	0,8000	0,0286	
	Auflösung / <i>resolution</i> Fz	N	1,0256	1,0256	2,0000	0,0800	
	Auflösung / <i>resolution</i> Mx	Nm	0,0077	0,0133	0,0250	0,0011	
	Auflösung / <i>resolution</i> My	Nm	0,0077	0,0133	0,0250	0,0011	
	Auflösung / <i>resolution</i> Mz	Nm	0,0087	0,0160	0,0250	0,0011	
	Merkmal / <i>characteristics</i>	Ursprung / <i>origin</i>		B	B	B	B; C
Anschluss / <i>connection</i>			CG	CG	CG	MP11	

Vergleichstabelle 6-Achsen Sensoren / Comparison table for 6-axis sensors

	Technische Daten / <i>technical data</i>	Einheit / <i>unit</i>	K6D80 1kN/50Nm	K6D80 2kN/100Nm	K6D80 5kN/250Nm	K6D110 1kN/100Nm
Sensortyp / sensor type	Bauform / <i>design</i>		FT Sensor	FT Sensor	FT Sensor	FT Sensor
	Messprinzip / <i>measuring principle</i>		6x DMS Vollbrücke / 6x strain gauge full bridge	6x DMS Vollbrücke / 6x strain gauge full bridge	6x DMS Vollbrücke / 6x strain gauge full bridge	6x DMS Vollbrücke / 6x strain gauge full bridge
	Konstruktion / <i>construction</i>		6x Druckstab / <i>pillar</i>	6x Druckstab / <i>pillar</i>	6x Druckstab / <i>pillar</i>	6x Druckstab / <i>pillar</i>
	Material / <i>material</i>		AL Legierung / <i>al alloy</i>	AL Legierung / <i>al alloy</i>	Stahl / <i>steel</i> , 1.4542	AL Legierung / <i>al alloy</i>
	Gewicht / <i>weight</i>	kg	0,450			0,880
Abmessungen / dimensions	Durchmesser / <i>diameter</i>	mm	80	80	80	110
	Höhe / <i>height</i>	mm	50	50	50	60
	Teilkreis / <i>pitch circle</i>	mm	60	60	60	80
Mechanische Daten / mechanical data	Nennkraft / <i>rated force</i> Fx	N	1000	2000	5000	1000
	Nennkraft / <i>rated force</i> Fy	N	1000	2000	5000	1000
	Nennkraft / <i>rated force</i> Fz	N	2500	5000	15000	2500
	Nennmoment / <i>rated torque</i> Mx	Nm	50	100	250	100
	Nennmoment / <i>rated torque</i> My	Nm	50	100	250	100
	Nennmoment / <i>rated torque</i> Mz	Nm	50	100	250	100
	Gebrauchskraft / <i>operating force</i> Fx	N	3000	6000	15000	3000
	Gebrauchskraft / <i>operating force</i> Fy	N	3000	6000	15000	3000
	Gebrauchskraft / <i>operating force</i> Fz	N	7500	15000	45000	7500
	Grenzbiegemoment / <i>bending moment limit</i> Mx	Nm	150	300	750	300
Grenzbiegemoment / <i>bending moment limit</i> My	Nm	150	300	750	300	
Grenzdrehmoment / <i>bending moment limit</i> Mz	Nm	150	300	750	300	

Vergleichstabelle 6-Achsen Sensoren / Comparison table for 6-axis sensors

	Technische Daten / <i>technical data</i>	Einheit / <i>unit</i>	K6D80 1kN/50Nm	K6D80 2kN/100Nm	K6D80 5kN/250Nm	K6D110 1kN/100Nm	
Elektrische Daten / <i>electrical data</i>	Nennkennwert / <i>rated characteristic value</i> Fx	mV/V	0,8	0,8	0,8	0,5	
	Nennkennwert / <i>rated characteristic value</i> Fy	mV/V	0,8	0,8	0,8	0,5	
	Nennkennwert / <i>rated characteristic value</i> Fz	mV/V	0,6	0,6	0,6	0,4	
	Nennkennwert / <i>rated characteristic value</i> Mx	mV/V	0,8	0,8	0,8	0,9	
	Nennkennwert / <i>rated characteristic value</i> My	mV/V	0,8	0,8	0,8	0,9	
	Nennkennwert / <i>rated characteristic value</i> Mz	mV/V	0,8	0,8	0,8	0,9	
	kleinster Anzeigeschritt mit GSV-1, GSV-6 (Rauschamplitude) / <i>smallest display step with „GSV-1, GSV-6“ (noise amplitude)</i>						
	Auflösung / <i>resolution</i> Fx	N	0,2500	0,5000	1,2500	0,4000	
	Auflösung / <i>resolution</i> Fy	N	0,2500	0,5000	1,2500	0,4000	
	Auflösung / <i>resolution</i> Fz	N	0,8333	1,6667	5,0000	1,2500	
	Auflösung / <i>resolution</i> Mx	Nm	0,0125	0,0250	0,0625	0,0222	
	Auflösung / <i>resolution</i> My	Nm	0,0125	0,0250	0,0625	0,0222	
	Auflösung / <i>resolution</i> Mz	Nm	0,0125	0,0250	0,0625	0,0222	
	kleinster Anzeigeschritt mit GSV-8 (Rauschamplitude) / <i>smallest display step with GSV-8 (noise amplitude)</i>						
	Auflösung / <i>resolution</i> Fx	N	0,0500	0,1000	0,2500	0,0800	
	Auflösung / <i>resolution</i> Fy	N	0,0500	0,1000	0,2500	0,0800	
	Auflösung / <i>resolution</i> Fz	N	0,1667	0,3333	1,0000	0,2500	
	Auflösung / <i>resolution</i> Mx	Nm	0,0025	0,0050	0,0125	0,0044	
	Auflösung / <i>resolution</i> My	Nm	0,0025	0,0050	0,0125	0,0044	
	Auflösung / <i>resolution</i> Mz	Nm	0,0025	0,0050	0,0125	0,0044	
	Merkmal / <i>characteristics</i>	Ursprung / <i>origin</i>		B; C	B; C	B; C	B; C
Anschluss / <i>connection</i>			MP11; CG	CG; MP11	CG; MP11	MP11	

Vergleichstabelle 6-Achsen Sensoren / Comparison table for 6-axis sensors

	Technische Daten / <i>technical data</i>	Einheit / <i>unit</i>	K6D110 4kN/250Nm	K6D110 8kN/500Nm	K6D110 10kN/750Nm	K6D130 1kN/200Nm
Sensortyp / sensor type	Bauform / <i>design</i>		FT Sensor	FT Sensor	FT Sensor	FT Sensor
	Messprinzip / <i>measuring principle</i>		6x DMS Vollbrücke / 6x strain gauge full bridge	6x DMS Vollbrücke / 6x strain gauge full bridge	6x DMS Vollbrücke / 6x strain gauge full bridge	6x DMS Vollbrücke / 6x strain gauge full bridge
	Konstruktion / <i>construction</i>		6x Druckstab / <i>pillar</i>	6x Druckstab / <i>pillar</i>	6x Druckstab / <i>pillar</i>	6x Druckstab / <i>pillar</i>
	Material / <i>material</i>		AL Legierung / <i>al alloy</i>	AL Legierung / <i>al alloy</i>	Stahl / <i>steel</i> , 1.4542	AL Legierung / <i>al alloy</i>
	Gewicht / <i>weight</i>	kg				
Abmessungen / dimensions	Durchmesser / <i>diameter</i>	mm	110	110	110	130
	Höhe / <i>height</i>	mm	60	60	60	80
	Teilkreis / <i>pitch circle</i>	mm	80	80	80	100
Mechanische Daten / mechanical data	Nennkraft / <i>rated force</i> Fx	N	4000	8000	10000	1000
	Nennkraft / <i>rated force</i> Fy	N	4000	8000	10000	1000
	Nennkraft / <i>rated force</i> Fz	N	10000	20000	25000	2500
	Nennmoment / <i>rated torque</i> Mx	Nm	250	500	750	200
	Nennmoment / <i>rated torque</i> My	Nm	250	500	750	200
	Nennmoment / <i>rated torque</i> Mz	Nm	250	500	750	200
	Gebrauchskraft / <i>operating force</i> Fx	N	12000	24000	30000	3000
	Gebrauchskraft / <i>operating force</i> Fy	N	12000	24000	30000	3000
	Gebrauchskraft / <i>operating force</i> Fz	N	30000	60000	100000	7500
	Grenzbiegemoment / <i>bending moment limit</i> Mx	Nm	750	1500	2250	400
Grenzbiegemoment / <i>bending moment limit</i> My	Nm	750	1500	2250	400	
Grenzdrehmoment / <i>bending moment limit</i> Mz	Nm	750	1500	2250	600	

Vergleichstabelle 6-Achsen Sensoren / Comparison table for 6-axis sensors

	Technische Daten / <i>technical data</i>	Einheit / <i>unit</i>	K6D110 4kN/250Nm	K6D110 8kN/500Nm	K6D110 10kN/750Nm	K6D130 1kN/200Nm	
Elektrische Daten / <i>electrical data</i>	Nennkennwert / <i>rated characteristic value</i> Fx	mV/V	0,8	0,8	0,8	0,4	
	Nennkennwert / <i>rated characteristic value</i> Fy	mV/V	0,8	0,8	0,8	0,4	
	Nennkennwert / <i>rated characteristic value</i> Fz	mV/V	0,6	0,5	0,5	0,4	
	Nennkennwert / <i>rated characteristic value</i> Mx	mV/V	0,8	0,8	0,8	0,8	
	Nennkennwert / <i>rated characteristic value</i> My	mV/V	0,8	0,8	0,8	0,8	
	Nennkennwert / <i>rated characteristic value</i> Mz	mV/V	0,8	0,8	0,8	0,8	
	kleinster Anzeigeschritt mit GSV-1, GSV-6 (Rauschamplitude) / <i>smallest display step with „GSV-1, GSV-6“ (noise amplitude)</i>						
	Auflösung / <i>resolution</i> Fx	N	1,0000	2,0000	2,5000	0,5000	
	Auflösung / <i>resolution</i> Fy	N	1,0000	2,0000	2,5000	0,5000	
	Auflösung / <i>resolution</i> Fz	N	3,3333	8,0000	10,0000	1,2500	
	Auflösung / <i>resolution</i> Mx	Nm	0,0625	0,1250	0,1875	0,0500	
	Auflösung / <i>resolution</i> My	Nm	0,0625	0,1250	0,1875	0,0500	
	Auflösung / <i>resolution</i> Mz	Nm	0,0625	0,1250	0,1875	0,0500	
	kleinster Anzeigeschritt mit GSV-8 (Rauschamplitude) / <i>smallest display step with GSV-8 (noise amplitude)</i>						
	Auflösung / <i>resolution</i> Fx	N	0,2000	0,4000	0,5000	0,1000	
	Auflösung / <i>resolution</i> Fy	N	0,2000	0,4000	0,5000	0,1000	
	Auflösung / <i>resolution</i> Fz	N	0,6667	1,6000	2,0000	0,2500	
	Auflösung / <i>resolution</i> Mx	Nm	0,0125	0,0250	0,0375	0,0100	
	Auflösung / <i>resolution</i> My	Nm	0,0125	0,0250	0,0375	0,0100	
	Auflösung / <i>resolution</i> Mz	Nm	0,0125	0,0250	0,0375	0,0100	
	Merkmal / <i>characteristics</i>	Ursprung / <i>origin</i>		B; C	B; C	B; C	B; C
Anschluss / <i>connection</i>			CG; MP11	MP11	CG; MP11	MP11	

Vergleichstabelle 6-Achsen Sensoren / Comparison table for 6-axis sensors

	Technische Daten / <i>technical data</i>	Einheit / <i>unit</i>	K6D130 5kN/500Nm	K6D130 15kN/1.2kNm	K6D150 2kN/200Nm	K6D150 4kN/500Nm
Sensortyp / sensor type	Bauform / <i>design</i>		FT Sensor	FT Sensor	FT Sensor	FT Sensor
	Messprinzip / <i>measuring principle</i>		6x DMS Vollbrücke / 6x strain gauge full bridge	6x DMS Vollbrücke / 6x strain gauge full bridge	6x DMS Vollbrücke / 6x strain gauge full bridge	6x DMS Vollbrücke / 6x strain gauge full bridge
	Konstruktion / <i>construction</i>		6x Druckstab / <i>pillar</i>	6x Druckstab / <i>pillar</i>	6x Druckstab / <i>pillar</i>	6x Druckstab / <i>pillar</i>
	Material / <i>material</i>		AL Legierung / <i>al alloy</i>	Stahl / <i>steel</i> , 1.4542	Al Legierung / <i>al alloy</i>	Al Legierung / <i>al alloy</i>
	Gewicht / <i>weight</i>	kg				
Abmessungen / dimensions	Durchmesser / <i>diameter</i>	mm	130	130	150	150
	Höhe / <i>height</i>	mm	80	80	90	90
	Teilkreis / <i>pitch circle</i>	mm	100	100	110	110
Mechanische Daten / mechanical data	Nennkraft / <i>rated force</i> Fx	N	5000	15000	2000	4000
	Nennkraft / <i>rated force</i> Fy	N	5000	15000	2000	4000
	Nennkraft / <i>rated force</i> Fz	N	15000	50000	5000	10000
	Nennmoment / <i>rated torque</i> Mx	Nm	500	1200	200	500
	Nennmoment / <i>rated torque</i> My	Nm	500	1200	200	500
	Nennmoment / <i>rated torque</i> Mz	Nm	500	1200	200	500
	Gebrauchskraft / <i>operating force</i> Fx	N	15000	45000	6000	12000
	Gebrauchskraft / <i>operating force</i> Fy	N	15000	45000	6000	12000
	Gebrauchskraft / <i>operating force</i> Fz	N	45000	100000	15000	30000
	Grenzbiegemoment / <i>bending moment limit</i> Mx	Nm	1500	2400	400	1000
Grenzbiegemoment / <i>bending moment limit</i> My	Nm	1500	2400	400	1000	
Grenzdrehmoment / <i>bending moment limit</i> Mz	Nm	1500	3600	600	1500	

Vergleichstabelle 6-Achsen Sensoren / Comparison table for 6-axis sensors

	Technische Daten / <i>technical data</i>	Einheit / <i>unit</i>	K6D130 5kN/500Nm	K6D130 15kN/1.2kNm	K6D150 2kN/200Nm	K6D150 4kN/500Nm	
Elektrische Daten / <i>electrical data</i>	Nennkennwert / <i>rated characteristic value</i> Fx	mV/V	0,8	0,8	0,8	0,8	
	Nennkennwert / <i>rated characteristic value</i> Fy	mV/V	0,8	0,8	0,8	0,8	
	Nennkennwert / <i>rated characteristic value</i> Fz	mV/V	0,8	0,9	0,8	0,8	
	Nennkennwert / <i>rated characteristic value</i> Mx	mV/V	0,8	1	0,8	0,8	
	Nennkennwert / <i>rated characteristic value</i> My	mV/V	0,8	1	0,8	0,8	
	Nennkennwert / <i>rated characteristic value</i> Mz	mV/V	0,8	0,8	0,8	0,8	
	kleinster Anzeigeschritt mit GSV-1, GSV-6 (Rauschamplitude) / <i>smallest display step with „GSV-1, GSV-6“ (noise amplitude)</i>						
	Auflösung / <i>resolution</i> Fx	N	1,2500	3,7500	0,5000	1,0000	
	Auflösung / <i>resolution</i> Fy	N	1,2500	3,7500	0,5000	1,0000	
	Auflösung / <i>resolution</i> Fz	N	3,7500	11,1111	1,2500	2,5000	
	Auflösung / <i>resolution</i> Mx	Nm	0,1250	0,2400	0,0500	0,1250	
	Auflösung / <i>resolution</i> My	Nm	0,1250	0,2400	0,0500	0,1250	
	Auflösung / <i>resolution</i> Mz	Nm	0,1250	0,3000	0,0500	0,1250	
	kleinster Anzeigeschritt mit GSV-8 (Rauschamplitude) / <i>smallest display step with GSV-8 (noise amplitude)</i>						
	Auflösung / <i>resolution</i> Fx	N	0,2500	0,7500	0,1000	0,2000	
	Auflösung / <i>resolution</i> Fy	N	0,2500	0,7500	0,1000	0,2000	
	Auflösung / <i>resolution</i> Fz	N	0,7500	2,2222	0,2500	0,5000	
	Auflösung / <i>resolution</i> Mx	Nm	0,0250	0,0480	0,0100	0,0250	
	Auflösung / <i>resolution</i> My	Nm	0,0250	0,0480	0,0100	0,0250	
	Auflösung / <i>resolution</i> Mz	Nm	0,0250	0,0600	0,0100	0,0250	
Merkmal / <i>characteristics</i>	Ursprung / <i>origin</i>		B; C	B; C	B; C	B; C	
	Anschluss / <i>connection</i>		CG; MP11	CG; MP11	MP11	MP11	

Vergleichstabelle 6-Achsen Sensoren / Comparison table for 6-axis sensors

	Technische Daten / <i>technical data</i>	Einheit / <i>unit</i>	K6D150 10kN/1kNm	K6D150 30kN/3kNm	K6D154 50N/5Nm	K6D154 100N/10Nm
Sensortyp / sensor type	Bauform / <i>design</i>		FT Sensor	FT Sensor	FT Sensor	FT Sensor
	Messprinzip / <i>measuring principle</i>		6x DMS Vollbrücke / 6x strain gauge full bridge	6x DMS Vollbrücke / 6x strain gauge full bridge	6x DMS Vollbrücke / 6x strain gauge full bridge	6x DMS Vollbrücke / 6x strain gauge full bridge
	Konstruktion / <i>construction</i>		6x Druckstab / <i>pillar</i>	6x Druckstab / <i>pillar</i>	6x Druckstab / <i>pillar</i>	6x Druckstab / <i>pillar</i>
	Material / <i>material</i>		Al Legierung / <i>al alloy</i>	Stahl / <i>steel</i> , 1.4542	Al Legierung / <i>al alloy</i>	Al Legierung / <i>al alloy</i>
	Gewicht / <i>weight</i>	kg			1,600	1,600
Abmessungen / dimensions	Durchmesser / <i>diameter</i>	mm	150	150	154	154
	Höhe / <i>height</i>	mm	90	90	100	100
	Teilkreis / <i>pitch circle</i>	mm	110	110	132	132
Mechanische Daten / mechanical data	Nennkraft / <i>rated force</i> Fx	N	10000	30000	50	100
	Nennkraft / <i>rated force</i> Fy	N	10000	30000	50	100
	Nennkraft / <i>rated force</i> Fz	N	25000	90000	100	200
	Nennmoment / <i>rated torque</i> Mx	Nm	1000	3000	5	10
	Nennmoment / <i>rated torque</i> My	Nm	1000	3000	5	10
	Nennmoment / <i>rated torque</i> Mz	Nm	1000	3000	5	10
	Gebrauchskraft / <i>operating force</i> Fx	N	30000	90000	200	400
	Gebrauchskraft / <i>operating force</i> Fy	N	30000	90000	200	400
	Gebrauchskraft / <i>operating force</i> Fz	N	75000	270000	600	1200
	Grenzbiegemoment / <i>bending moment limit</i> Mx	Nm	2000	6000	25	50
Grenzbiegemoment / <i>bending moment limit</i> My	Nm	2000	6000	25	50	
Grenzdrehmoment / <i>bending moment limit</i> Mz	Nm	3000	9000	25	50	

Vergleichstabelle 6-Achsen Sensoren / Comparison table for 6-axis sensors

	Technische Daten / <i>technical data</i>	Einheit / <i>unit</i>	K6D150 10kN/1kNm	K6D150 30kN/3kNm	K6D154 50N/5Nm	K6D154 100N/10Nm	
Elektrische Daten / <i>electrical data</i>	Nennkennwert / <i>rated characteristic value</i> Fx	mV/V	0,8	0,8	0,56	0,52	
	Nennkennwert / <i>rated characteristic value</i> Fy	mV/V	0,8	0,8	0,56	0,52	
	Nennkennwert / <i>rated characteristic value</i> Fz	mV/V	0,8	0,8	0,32	0,32	
	Nennkennwert / <i>rated characteristic value</i> Mx	mV/V	0,8	0,8	0,4	0,44	
	Nennkennwert / <i>rated characteristic value</i> My	mV/V	0,8	0,8	0,4	0,44	
	Nennkennwert / <i>rated characteristic value</i> Mz	mV/V	0,8	0,8	0,4	0,4	
	kleinster Anzeigeschritt mit GSV-1, GSV-6 (Rauschamplitude) / <i>smallest display step with „GSV-1, GSV-6“ (noise amplitude)</i>						
	Auflösung / <i>resolution</i> Fx	N	2,5000	7,5000	0,0179	0,0385	
	Auflösung / <i>resolution</i> Fy	N	2,5000	7,5000	0,0179	0,0385	
	Auflösung / <i>resolution</i> Fz	N	6,2500	22,5000	0,0625	0,1250	
	Auflösung / <i>resolution</i> Mx	Nm	0,2500	0,7500	0,0025	0,0045	
	Auflösung / <i>resolution</i> My	Nm	0,2500	0,7500	0,0025	0,0045	
	Auflösung / <i>resolution</i> Mz	Nm	0,2500	0,7500	0,0025	0,0050	
	kleinster Anzeigeschritt mit GSV-8 (Rauschamplitude) / <i>smallest display step with GSV-8 (noise amplitude)</i>						
	Auflösung / <i>resolution</i> Fx	N	0,5000	1,5000	0,0036	0,0077	
	Auflösung / <i>resolution</i> Fy	N	0,5000	1,5000	0,0036	0,0077	
	Auflösung / <i>resolution</i> Fz	N	1,2500	4,5000	0,0125	0,0250	
	Auflösung / <i>resolution</i> Mx	Nm	0,0500	0,1500	0,0005	0,0009	
	Auflösung / <i>resolution</i> My	Nm	0,0500	0,1500	0,0005	0,0009	
	Auflösung / <i>resolution</i> Mz	Nm	0,0500	0,1500	0,0005	0,0010	
	Merkmal / <i>characteristics</i>	Ursprung / <i>origin</i>		B; C	B; C	B; C	B; C
Anschluss / <i>connection</i>			MP11	MP11	UP13	UP13	

Vergleichstabelle 6-Achsen Sensoren / Comparison table for 6-axis sensors

	Technische Daten / <i>technical data</i>	Einheit / <i>unit</i>	K6D154 200N/20Nm	K6D154 500N/50Nm	K6D175 10kN/1kNm	K6D175 20kN/2kNm
Sensortyp / sensor type	Bauform / <i>design</i>		FT Sensor	FT Sensor	FT Sensor	FT Sensor
	Messprinzip / <i>measuring principle</i>		6x DMS Vollbrücke / <i>6x strain gauge full bridge</i>	6x DMS Vollbrücke / <i>6x strain gauge full bridge</i>	6x DMS Vollbrücke / <i>6x strain gauge full bridge</i>	6x DMS Vollbrücke / <i>6x strain gauge full bridge</i>
	Konstruktion / <i>construction</i>		6x Druckstab / <i>pillar</i>	6x Druckstab / <i>pillar</i>	6x Druckstab / <i>pillar</i>	6x Druckstab / <i>pillar</i>
	Material / <i>material</i>		Al Legierung / <i>al alloy</i>	Al Legierung / <i>al alloy</i>	Stahl / <i>steel, 1.4542</i>	Stahl / <i>steel, 1.4542</i>
	Gewicht / <i>weight</i>	kg	1,600	1,600		
Abmessungen / dimensions	Durchmesser / <i>diameter</i>	mm	154	154	175	175
	Höhe / <i>height</i>	mm	100	100	110	110
	Teilkreis / <i>pitch circle</i>	mm	132	132	164	164
Mechanische Daten / mechanical data	Nennkraft / <i>rated force</i> Fx	N	200	500	10000	20000
	Nennkraft / <i>rated force</i> Fy	N	200	500	10000	20000
	Nennkraft / <i>rated force</i> Fz	N	500	1000	20000	50000
	Nennmoment / <i>rated torque</i> Mx	Nm	20	50	1000	2000
	Nennmoment / <i>rated torque</i> My	Nm	20	50	1000	2000
	Nennmoment / <i>rated torque</i> Mz	Nm	20	50	2000	5000
	Gebrauchskraft / <i>operating force</i> Fx	N	800	2500	30000	60000
	Gebrauchskraft / <i>operating force</i> Fy	N	800	2500	30000	60000
	Gebrauchskraft / <i>operating force</i> Fz	N	3000	7000	80000	200000
	Grenzbiegemoment / <i>bending moment limit</i> Mx	Nm	100	250	3000	6000
Grenzbiegemoment / <i>bending moment limit</i> My	Nm	100	250	3000	6000	
Grenzdrehmoment / <i>bending moment limit</i> Mz	Nm	100	250	6000	15000	

Vergleichstabelle 6-Achsen Sensoren / Comparison table for 6-axis sensors

	Technische Daten / <i>technical data</i>	Einheit / <i>unit</i>	K6D154 200N/20Nm	K6D154 500N/50Nm	K6D175 10kN/1kNm	K6D175 20kN/2kNm	
Elektrische Daten / <i>electrical data</i>	Nennkennwert / <i>rated characteristic value</i> Fx	mV/V	0,52	0,4	0,68	0,6	
	Nennkennwert / <i>rated characteristic value</i> Fy	mV/V	0,52	0,4	0,68	0,6	
	Nennkennwert / <i>rated characteristic value</i> Fz	mV/V	0,36	0,3	0,45	0,5	
	Nennkennwert / <i>rated characteristic value</i> Mx	mV/V	0,44	0,4	0,64	0,6	
	Nennkennwert / <i>rated characteristic value</i> My	mV/V	0,44	0,4	0,64	0,6	
	Nennkennwert / <i>rated characteristic value</i> Mz	mV/V	0,4	0,4	0,64	0,6	
	kleinster Anzeigeschritt mit GSV-1, GSV-6 (Rauschamplitude) / <i>smallest display step with „GSV-1, GSV-6“ (noise amplitude)</i>						
	Auflösung / <i>resolution</i> Fx	N	0,0769	0,2500	2,9412	6,6667	
	Auflösung / <i>resolution</i> Fy	N	0,0769	0,2500	2,9412	6,6667	
	Auflösung / <i>resolution</i> Fz	N	0,2778	0,6667	8,8889	20,0000	
	Auflösung / <i>resolution</i> Mx	Nm	0,0091	0,0250	0,3125	0,6667	
	Auflösung / <i>resolution</i> My	Nm	0,0091	0,0250	0,3125	0,6667	
	Auflösung / <i>resolution</i> Mz	Nm	0,0100	0,0250	0,6250	1,6667	
	kleinster Anzeigeschritt mit GSV-8 (Rauschamplitude) / <i>smallest display step with GSV-8 (noise amplitude)</i>						
	Auflösung / <i>resolution</i> Fx	N	0,0154	0,0500	0,5882	1,3333	
	Auflösung / <i>resolution</i> Fy	N	0,0154	0,0500	0,5882	1,3333	
	Auflösung / <i>resolution</i> Fz	N	0,0556	0,1333	1,7778	4,0000	
	Auflösung / <i>resolution</i> Mx	Nm	0,0018	0,0050	0,0625	0,1333	
	Auflösung / <i>resolution</i> My	Nm	0,0018	0,0050	0,0625	0,1333	
Auflösung / <i>resolution</i> Mz	Nm	0,0020	0,0050	0,1250	0,3333		
Merkmal / <i>characteristics</i>	Ursprung / <i>origin</i>		B; C	B; C	B; C	B; C	
	Anschluss / <i>connection</i>		UP13	UP13	UP13	UP13	

Vergleichstabelle 6-Achsen Sensoren / Comparison table for 6-axis sensors

	Technische Daten / <i>technical data</i>	Einheit / <i>unit</i>	K6D175 50kN/5kNm	K6D225 50kN/10kNm	K6D225 100kN/15kNm	K6D225 200kN/20kNm
Sensortyp / sensor type	Bauform / <i>design</i>		FT Sensor	FT Sensor	FT Sensor	FT Sensor
	Messprinzip / <i>measuring principle</i>		6x DMS Vollbrücke / 6x strain gauge full bridge	12x DMS Vollbrücke / 12x strain gauge full bridge	12x DMS Vollbrücke / 12x strain gauge full bridge	12x DMS Vollbrücke / 12x strain gauge full bridge
	Konstruktion / <i>construction</i>		6x Druckstab / <i>pillar</i>	6x Druckstab / <i>pillar</i>	6x Druckstab / <i>pillar</i>	6x Druckstab / <i>pillar</i>
	Material / <i>material</i>		Stahl / <i>steel</i> , 1.4542	Stahl / <i>steel</i> , 1.4542	Stahl / <i>steel</i> , 1.4542	Stahl / <i>steel</i> , 1.4542
	Gewicht / <i>weight</i>	kg				
Abmessungen / dimensions	Durchmesser / <i>diameter</i>	mm	175	225	225	225
	Höhe / <i>height</i>	mm	110	140	140	140
	Teilkreis / <i>pitch circle</i>	mm	164	180	180	180
Mechanische Daten / mechanical data	Nennkraft / <i>rated force</i> Fx	N	50000	50000	100000	200000
	Nennkraft / <i>rated force</i> Fy	N	50000	50000	100000	200000
	Nennkraft / <i>rated force</i> Fz	N	100000	100000	250000	500000
	Nennmoment / <i>rated torque</i> Mx	Nm	5000	10000	15000	20000
	Nennmoment / <i>rated torque</i> My	Nm	5000	10000	15000	20000
	Nennmoment / <i>rated torque</i> Mz	Nm	10000	10000	15000	20000
	Gebrauchskraft / <i>operating force</i> Fx	N	150000	100000	200000	400000
	Gebrauchskraft / <i>operating force</i> Fy	N	150000	100000	200000	400000
	Gebrauchskraft / <i>operating force</i> Fz	N	400000	200000	500000	1000000
	Grenzbiegemoment / <i>bending moment limit</i> Mx	Nm	15000	45000	45000	60000
Grenzbiegemoment / <i>bending moment limit</i> My	Nm	15000	45000	45000	60000	
Grenzdrehmoment / <i>bending moment limit</i> Mz	Nm	30000	45000	45000	60000	

Vergleichstabelle 6-Achsen Sensoren / Comparison table for 6-axis sensors

	Technische Daten / <i>technical data</i>	Einheit / <i>unit</i>	K6D175 50kN/5kNm	K6D225 50kN/10kNm	K6D225 100kN/15kNm	K6D225 200kN/20kNm	
Elektrische Daten / <i>electrical data</i>	Nennkennwert / <i>rated characteristic value</i> Fx	mV/V	0,7	0,5	1	1	
	Nennkennwert / <i>rated characteristic value</i> Fy	mV/V	0,7	0,5	1	1	
	Nennkennwert / <i>rated characteristic value</i> Fz	mV/V	0,52	0,35	0,7	0,7	
	Nennkennwert / <i>rated characteristic value</i> Mx	mV/V	0,8	0,5	0,7	0,7	
	Nennkennwert / <i>rated characteristic value</i> My	mV/V	0,8	0,5	0,7	0,7	
	Nennkennwert / <i>rated characteristic value</i> Mz	mV/V	0,65	0,5	0,7	0,7	
	kleinster Anzeigeschritt mit GSV-1, GSV-6 (Rauschamplitude) / <i>smallest display step with „GSV-1, GSV-6“ (noise amplitude)</i>						
	Auflösung / <i>resolution</i> Fx	N	14,2857	20,0000	20,0000	40,0000	
	Auflösung / <i>resolution</i> Fy	N	14,2857	20,0000	20,0000	40,0000	
	Auflösung / <i>resolution</i> Fz	N	38,4615	57,1429	71,4286	142,8571	
	Auflösung / <i>resolution</i> Mx	Nm	1,2500	4,0000	4,2857	5,7143	
	Auflösung / <i>resolution</i> My	Nm	1,2500	4,0000	4,2857	5,7143	
	Auflösung / <i>resolution</i> Mz	Nm	3,0769	4,0000	4,2857	5,7143	
	kleinster Anzeigeschritt mit GSV-8 (Rauschamplitude) / <i>smallest display step with GSV-8 (noise amplitude)</i>						
	Auflösung / <i>resolution</i> Fx	N	2,8571	4,0000	4,0000	8,0000	
	Auflösung / <i>resolution</i> Fy	N	2,8571	4,0000	4,0000	8,0000	
	Auflösung / <i>resolution</i> Fz	N	7,6923	11,4286	14,2857	28,5714	
	Auflösung / <i>resolution</i> Mx	Nm	0,2500	0,8000	0,8571	1,1429	
	Auflösung / <i>resolution</i> My	Nm	0,2500	0,8000	0,8571	1,1429	
	Auflösung / <i>resolution</i> Mz	Nm	0,6154	0,8000	0,8571	1,1429	
Merkmal / <i>characteristics</i>	Ursprung / <i>origin</i>		B; C	C	C	C	
	Anschluss / <i>connection</i>		UP13	UP13	UP13	UP13	

Vergleichstabelle 6-Achsen Sensoren / Comparison table for 6-axis sensors

	Technische Daten / <i>technical data</i>	Einheit / <i>unit</i>	K6D300 400kN/40kNm
Sensortyp / sensor type	Bauform / <i>design</i>		FT Sensor
	Messprinzip / <i>measuring principle</i>		12x DMS Vollbrücke / <i>12x strain gauge full bridge</i>
	Konstruktion / <i>construction</i>		6x Druckstab / <i>pillar</i>
	Material / <i>material</i>		Stahl / <i>steel</i> , 1.4542
	Gewicht / <i>weight</i>	kg	
Abmessungen / dimensions	Durchmesser / <i>diameter</i>	mm	300
	Höhe / <i>height</i>	mm	175
	Teilkreis / <i>pitch circle</i>	mm	220
Mechanische Daten / mechanical data	Nennkraft / <i>rated force</i> Fx	N	400000
	Nennkraft / <i>rated force</i> Fy	N	400000
	Nennkraft / <i>rated force</i> Fz	N	800000
	Nennmoment / <i>rated torque</i> Mx	Nm	40000
	Nennmoment / <i>rated torque</i> My	Nm	40000
	Nennmoment / <i>rated torque</i> Mz	Nm	40000
	Gebrauchskraft / <i>operating force</i> Fx	N	800000
	Gebrauchskraft / <i>operating force</i> Fy	N	800000
	Gebrauchskraft / <i>operating force</i> Fz	N	1600000
	Grenzbiegemoment / <i>bending moment limit</i> Mx	Nm	80000
Grenzbiegemoment / <i>bending moment limit</i> My	Nm	80000	
Grenzdrehmoment / <i>bending moment limit</i> Mz	Nm	80000	

Vergleichstabelle 6-Achsen Sensoren / Comparison table for 6-axis sensors

	Technische Daten / <i>technical data</i>	Einheit / <i>unit</i>	K6D300 400kN/40kNm	
Elektrische Daten / <i>electrical data</i>	Nennkennwert / <i>rated characteristic value</i> Fx	mV/V	0,8	
	Nennkennwert / <i>rated characteristic value</i> Fy	mV/V	0,8	
	Nennkennwert / <i>rated characteristic value</i> Fz	mV/V	0,4	
	Nennkennwert / <i>rated characteristic value</i> Mx	mV/V	0,5	
	Nennkennwert / <i>rated characteristic value</i> My	mV/V	0,5	
	Nennkennwert / <i>rated characteristic value</i> Mz	mV/V	0,5	
	kleinster Anzeigeschritt mit GSV-1, GSV-6 (Rauschamplitude) / <i>smallest display step with „GSV-1, GSV-6“ (noise amplitude)</i>			
	Auflösung / <i>resolution</i> Fx	N	100,0000	
	Auflösung / <i>resolution</i> Fy	N	100,0000	
	Auflösung / <i>resolution</i> Fz	N	400,0000	
	Auflösung / <i>resolution</i> Mx	Nm	16,0000	
	Auflösung / <i>resolution</i> My	Nm	16,0000	
	Auflösung / <i>resolution</i> Mz	Nm	16,0000	
	kleinster Anzeigeschritt mit GSV-8 (Rauschamplitude) / <i>smallest display step with GSV-8 (noise amplitude)</i>			
	Auflösung / <i>resolution</i> Fx	N	20,0000	
	Auflösung / <i>resolution</i> Fy	N	20,0000	
	Auflösung / <i>resolution</i> Fz	N	80,0000	
	Auflösung / <i>resolution</i> Mx	Nm	3,2000	
	Auflösung / <i>resolution</i> My	Nm	3,2000	
	Auflösung / <i>resolution</i> Mz	Nm	3,2000	
	Merkmal / <i>characteristics</i>	Ursprung / <i>origin</i>		C
Anschluss / <i>connection</i>			UP13	

Vergleichstabelle 6-Achsen Sensoren / Comparison table for 6-axis sensors

Merkmal / characteristic	Abkürzung / abbreviation	Bedeutung / meaning
Ursprung / origin	A	<p>Ursprung im Zentrum des Sensors (nur bei K6D68); Bei der Kalibrierung werden die Kräfte F_x, F_y, F_z so eingeleitet, dass sich deren Wirkungslinien im Zentrum des Sensors schneiden. / <i>Origin in the center of the sensor (only for K6D68); During the calibration, the forces F_x, F_y, F_z are introduced in such way that their lines of action intersect at the center of the sensor.</i></p>
	B	<p>Der Ursprung des Koordinatensystems befindet sich außerhalb des Sensors in der Ebene der Auflagefläche und im Zentrum des Zentrierbunds. Methode B ist die Standard Kalibrierung. Um die Höhe des Zentrierbunds versetzt ist eine Gravierung mit den Koordinatenachsen vorhanden. / <i>The origin of the coordinate system is located outside the sensor in the level of the bearing surface and in the center of the centering collar. Method B is the standard calibration. An engraving with the coordinate axes is provided to displace the height of the centering collar.</i></p>
	C	<p>Der Ursprung des Koordinatensystems ist außerhalb des Sensors, auf der Mittelachse des Sensors (z-Achse) verschoben. Durch eine Kalibrierung, die weitgehend in der Einbausituation entspricht, lassen sich Messfehler durch Übersprechen reduzieren. Für die Sensoren K6D68, K6D80, K6D110, K6D130 ist eine Kalibrierung in 140mm Distanz von der Oberfläche (mit reduzierten Kräften) möglich. / <i>The origin of the coordinate system is displaced outside the sensor, on the central axis of the sensor (z-axis). A calibration, which largely corresponds to the installation situation, allows measurement errors to be reduced by means of crosstalk. For the sensors K6D68, K6D80, K6D110, K6D130 a calibration is possible at a distance of 140mm from the surface (with reduced forces).</i></p>
Temperatur- kompensation / temperature compensation	Std	<p>Standard Temperaturkompensation, insbesondere für Miniatur Sensoren K6D27, K6D40. Die Drift der Kalibrierfaktoren beträgt ca. $+0.07\%$ RD/°C für Sensoren aus Aluminium und $+0.02\%$ RD/°C für Sensoren aus Stahl. Im Temperaturbereich $20^\circ\text{C} \pm 10^\circ\text{C}$ beträgt die Drift der Kalibrierfaktoren $\pm 0,7\%$ RD (vom Istwert) für Sensoren aus Aluminium und $\pm 0.2\%$ RD (vom Istwert) für Sensoren aus Stahl. Das Nullsignal der Sensoren im unbelasteten Zustand liegt im Bereich ± 1.5 mV/V. Das Nullsignal im unbelasteten Zustand wird von der Auswerteelektronik abgeglichen. Die Drift des Nullsignals beträgt $\pm 0.1\%$ FS/°C. / <i>Standard temperature compensation, especially for miniature sensors K6D27, K6D40. The drift of the calibration factors is approx. $+0.07\%$ RD/°C for sensors made of aluminum and $+0.02\%$ RD/°C for sensors made of steel. In the temperature range of $20^\circ\text{C} \pm 10^\circ\text{C}$, the drift of the calibration factors is $\pm 0.7\%$ RD (of the actual value) for sensors made of aluminum and $\pm 0.2\%$ RD (of the actual value) for those of steel. The zero signal of the sensors in the unloaded state is in the range of ± 1.5 mV/V. The zero signal in the unloaded state is adjusted by the evaluation electronics. The drift of the zero signal is $\pm 0.1\%$ FS/°C.</i></p>
	ITC	<p>Typische Temperaturkompensation für 6-Achsen Kraft-/Momentensensoren. Die Drift der Kalibrierfaktoren beträgt ca. $\pm 0,005\%$ RD/°C. Das Nullsignal der Sensoren im unbelasteten Zustand liegt im Bereich -0.05 mV/V bis $+0.05$ mV/V. Die Drift des Nullsignals beträgt ca. $\pm 0.01\%$ FS/°C. / <i>Typical temperature compensation for 6-axis force/torque sensors. The drift of the calibration factors is approx. $\pm 0.005\%$ RD/°C. The zero signal of the sensors in the unloaded state is in the range of -0.05 mV/V to $+0.05$ mV/V. The drift of the zero signal is approx. $\pm 0.01\%$ FS/°C.</i></p>

Vergleichstabelle 6-Achsen Sensoren / Comparison table for 6-axis sensors

Merkmal / characteristic	Abkürzung / abbreviation	Bedeutung / meaning
	CG	<p>Kabelverschraubung. Der Sensor wird mit 5m Anschlusskabel geliefert. Für den Anschluss an den Messverstärker GSV-8DS SubD44HD wird eine Ausführung mit werkseitig konfektioniertem Sub-D44 HD Steckverbinder empfohlen. Für den Anschluss an den Messverstärker GSV-8AS (oder GSV-1A8USB M16/K6D) wird eine Ausführung mit werkseitig konfektioniertem M16-Rundsteckverbinder empfohlen. / <i>Cable gland. The sensor is supplied with a 5m connection cable. Für den Anschluss an den Messverstärker GSV-8DS SubD44HD wird eine Ausführung mit werkseitig konfektioniertem Sub-D44 HD Steckverbinder empfohlen. For the connection with the measuring amplifier GSV-8DS SubD44HD an implementation with an factory assembled Sub-D44 HD plug connector is recommended. For the connection with the measuring amplifier GSV-8AS (or GSV-1A8USB M16/K6D) an implementation with factory assembled M16-round plug connector is recommended.</i></p>
	MP11	<p>Extrem robuster 24-poliger Steckverbinder in IP68 Ausführung von Fischer. Im Sensor optional integriert bei den Sensoren F6D, K6D80, K6D110, K6D130. Anschlusskabel, 5m, MP11 (f) zum Sensor, Sub-D44 HD (m) zum GSV-8DS Sub-D44HD (ME Art.: SO044) / <i>Extremely robust 24-pole connector in IP68 version by Fischer. In the sensor optionally integrated with the sensors F6D, K6D80, K6D110, K6D130. Connection cable, 5m, MP11 (f) to the sensor, Sub-D44 HD (m) to the GSV-8DS Sub-D44HD (ME Art.: SO044) DE: http://www.fischerconnectors.com/germany/de/produkte/minimax US: http://www.fischerconnectors.com/us/en/products/minimax</i></p>

Merkmal / characteristic	Abkürzung / abbreviation	Bedeutung / meaning
Anschluss / connection	M16	<p>24-poliger Rundsteckverbinder, integriert bei den Sensoren K6D154 und K6D175</p> <p>Anschluss Sensor-Messverstärker: Anschlusskabel, 5m, M16 (f) zum Sensor, Sub-D44HD (m) zum GSV-8DS SubD44HD (ME Art.: SO045); Anschlusskabel, 5m, M16 (f) zum Sensor, M16 (m) zum GSV-8AS oder GSV-1A8USB M16/K6D (ME Art.: SO040);</p> <p>Rundsteckverbinder (f) zum Sensor: M16 Winkeldose, 24-polig, female, D=6-8mm Binder-Art.:99 5696 75 24 oder M16-Kabeldose, 24-polig, female, D=4-6mm, Binder-Art.:99 5496 15 24, oder M16-Kabeldose, 24-polig, female, D=6-8mm Binder-Art.:99 5696 15 24</p> <p>Rundsteckverbinder (m) zum Messverstärker: Binder-Art.:99 5495 00 24 für Kabel Durchmesser 4...6mm oder Binder-Art.:99 5695 00 24 für Kabel Durchmesser 6...8mm</p> <p>Einbaubuchse (f) im Messverstärker: Binder-Art.: 09-0498-80-24, Serie 723, 24polig; mit Einzellitzen 24x 0,14 120mm konfektioniert (ME Art.:7944)</p> <p>Einbaustecker (m) im Sensor: Binder-Art.: 09-0497-00-24, Serie 723, 24polig; mit Einzellitzen 24x0,027 (ME Art.: 5135) / <i>24-pole round plug connector, integrated in the K6D154 and K6D175 sensors</i></p> <p>Connection sensor-measuring amplifier: <i>connection cable, 5m, M16 (f) to the sensor, Sub-D44HD (m) to the GSV-8DS SubD44HD (ME Art.: SO045); connection cable, 5m, M16 (f) to the sensor, M16 (m) to the GSV-8AS or GSV-1A8USB M16/K6D (ME Art.: SO040);</i></p> <p>Round plug connector (f) to the sensor: <i>M16 angled socket, 24-pole, female, D=6-8mm binder-Art.:99 5696 75 24 or M16-cable socket, 24-pole, female, D=4-6mm, binder-Art.:99 5496 15 24, or M16-cable socket, 24-pole, female, D=6-8mm binder-Art.:99 5696 15 24</i></p> <p>Round plug connector (m) to the measuring amplifier: <i>Binder-Art.:99 5495 00 24 for cable diameter 4...6mm or Binder-Art.:99 5695 00 24 for cable diameter 6...8mm</i></p> <p>Built-in socket (f) in the measuring amplifier: <i>Binder-Art.: 09-0498-80-24, series 723, 24pole; assembled with single strands 24x 0,14 120mm (ME Art.:7944)</i></p> <p>Built-in socket (m) in sensor: <i>Binder-Art.: 09-0497-00-24, series 723, 24pole; with single strands 24x0,027 (ME Art.: 5135)</i> DE: https://www.binder-connector.de/de/produkte/miniatur-steckverbinder/m-16-steckverbinder-ip-67/ US: https://www.binder-connector.com/en/products/miniature-circular-connectors/m16-ip67/</p>

Vergleichstabelle 6-Achsen Sensoren / Comparison table for 6-axis sensors

Merkmal / characteristic	Abkürzung / abbreviation	Bedeutung / meaning
	M12	<p>Robuster 5-poliger Rundsteckverbinder, integriert bei den Sensoren F6D100-50e und F6D80-40e; Anschluss Sensor-Windows-PC mit GSVmulti: Anschlusskabel „Extension 5p/f/M12/5p/m/M12/5,0 (ME Art: 5625), Phoenix-Art:1536120 + F6D-CAN-Adapter + PCAN-USB-Adapter / <i>Robust 5-pole round plug connector, integrated with the sensors F6D100-50e and F6D80-40e;</i> Connection Sensor-Windows-PC with GSVmulti: Connection cable „Extension 5p/f/M12/5p/m/M12/5,0 (ME Art: 5625), Phoenix-Art:1536120 + F6D-CAN-Adapter + PCAN-USB-Adapter</p>
	UP13	<p>27-poliger Rundsteckverbinder UP13, integriert bei den Sensoren K6D225 und K6D300 Anschlusskabel, 5m, UP13 (m) zum Sensor, Sub-D44 HD (m) zum GSV-8DS Sub-D44HD / <i>27-pin round connector UP13, integrated in K6D225 and K6D300</i> Connection cable, 5 m, UP13 (m) to the sensor, Sub-D44 HD (m) to the GSV-8DS Sub-D44HD</p>

Abb. 1: Ursprung des Koordinatensystems



Abb. 2: Rundsteckverbinder Binder M16 und Fischer MP11



STRAIGHT OVERMOLDING

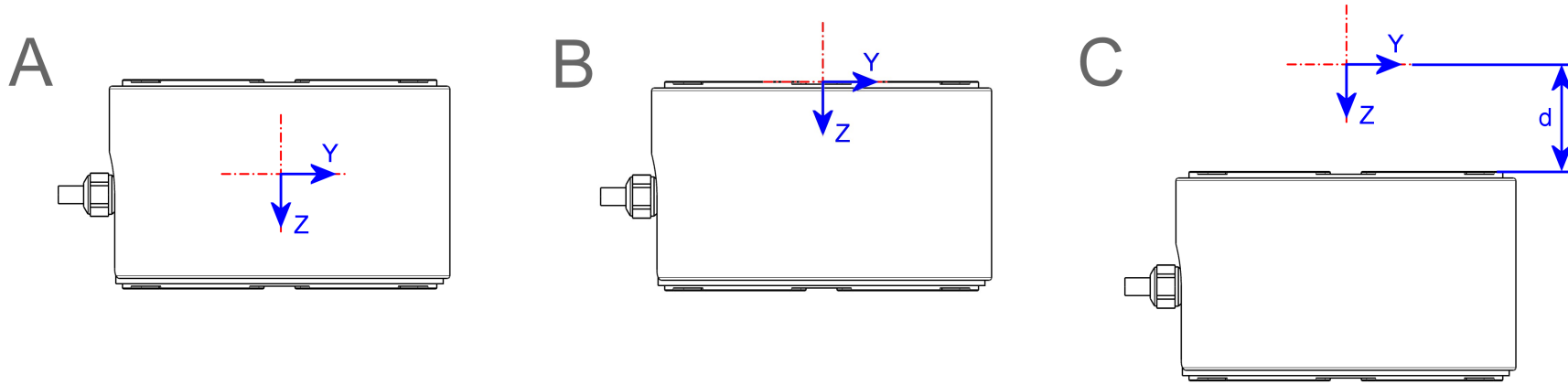
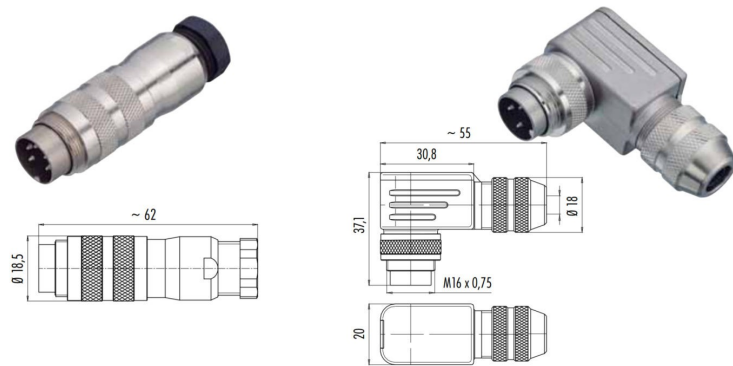
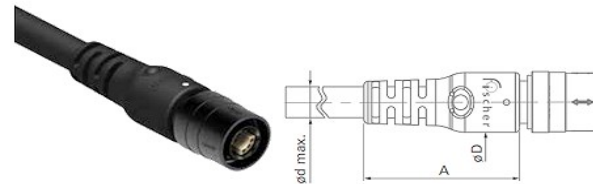

RIGHT-ANGLE OVERMOLDING

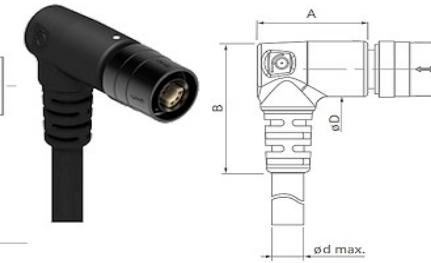

Angle	ød	øD	A	B
Straight	Ø 6.7	Ø 12.8	30	-
90°	Ø 6.7	Ø 12.8	23	30