



Mounting instructions for 3-axis sensors



Contents

General information.....	3
K3D40.....	4
K3D60a.....	7
K3D120.....	10
K3D160.....	13
K3D300.....	16
K3D400.....	19



General information

Please note the following instructions for mounting the K3D products of ME-Measuring systems GmbH.

For proper installation, the K3D sensor must be assembled to the special marked mounting surfaces.

K3D40

Mounting surface:

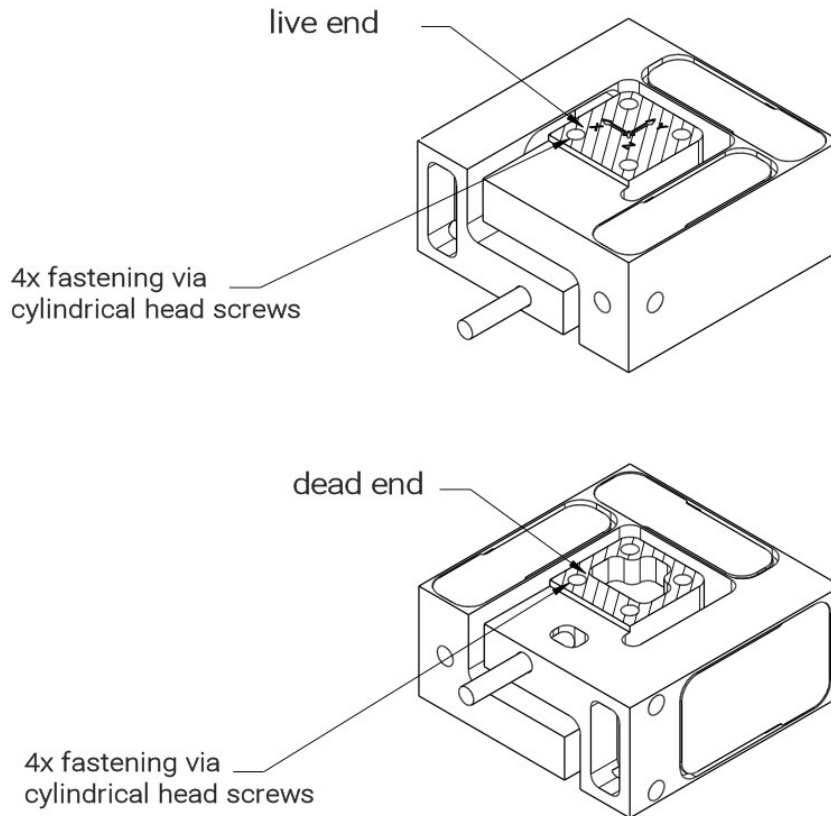

Mounting: live and dead end

The fastening of the measuring construction has to be done on the mounting surface live end / dead end of the K3D sensor. For this, the threads, pin holes and tightening torques specified in the table below must be used. The screw depth in the live end / dead end should be 5-7 mm.

Requirements for mounting surface

- screw depth for thread min. 1.0 up to 1.5 x Ø
- high stiffness of the mounting surface, no deformation under load
- flatness of mounting surface 0.05 to 0.1mm
- quality of the mounting surface Rz6.3Ø

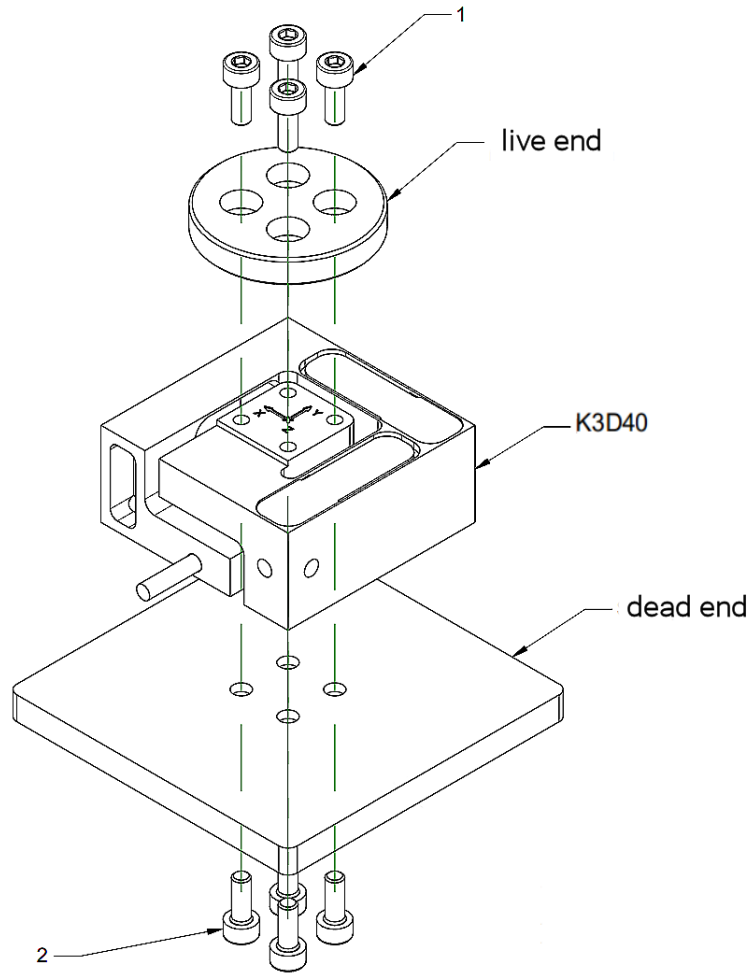

Pos.	Quantity	Designation	Material	Nominal load	Tightening torque (Nm) live end	Tightening torque (Nm) dead end
1	4	Cylindrical head screws DIN EN ISO 4762 M3	Aluminium alloy	±2N ±10N ±20N ±50N	1	1
2	4	Cylindrical head screws DIN EN ISO 4762 M3				



Note:

The distance between sensor body and fastening elements must be 1 mm.

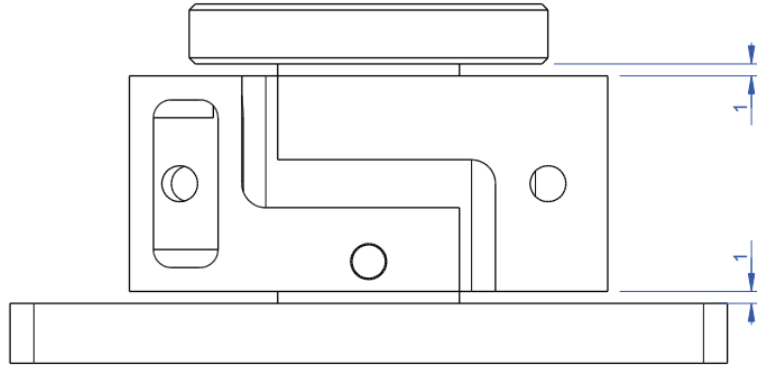

K3D60a

Mounting surface:

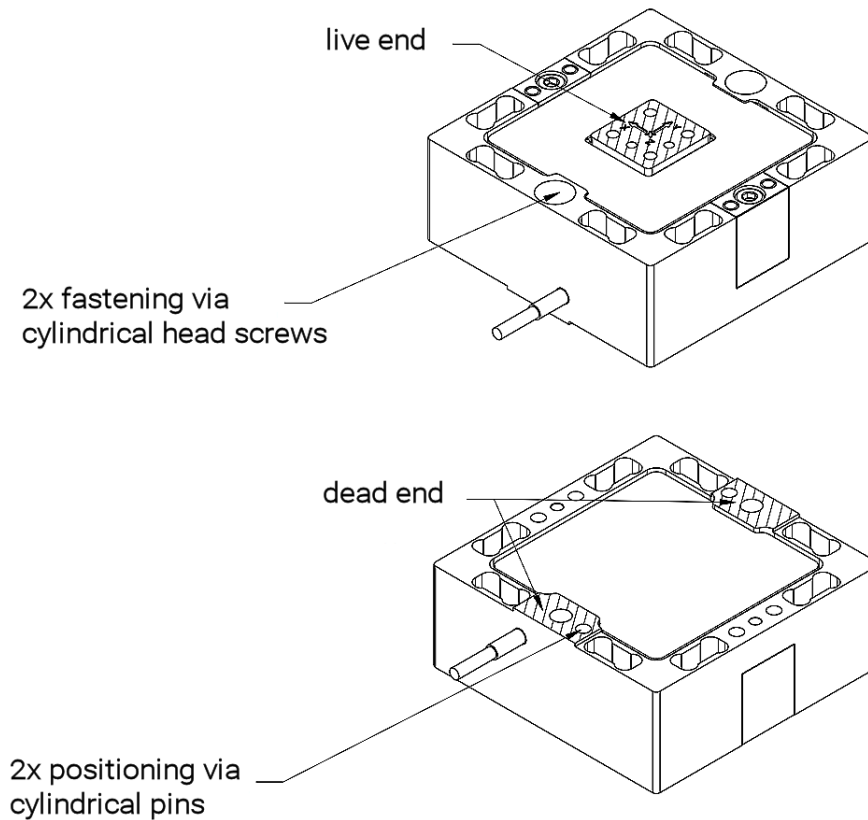

Mounting: live and dead end

The fastening of the measuring construction has to be done on the mounting surface live end / dead end of the K3D sensor. For this, the threads, pin holes and tightening torques specified in the table below must be used. The screw depth in the live end / dead end should be 6-10 mm.

Requirements for mounting surface

- screw depth for thread min. 1.0 up to $1.5 \times \varnothing$
- high stiffness of the mounting surface, no deformation under load
- flatness of mounting surface 0.05 to 0.1mm
- quality of the mounting surface $Rz6.3\varnothing$

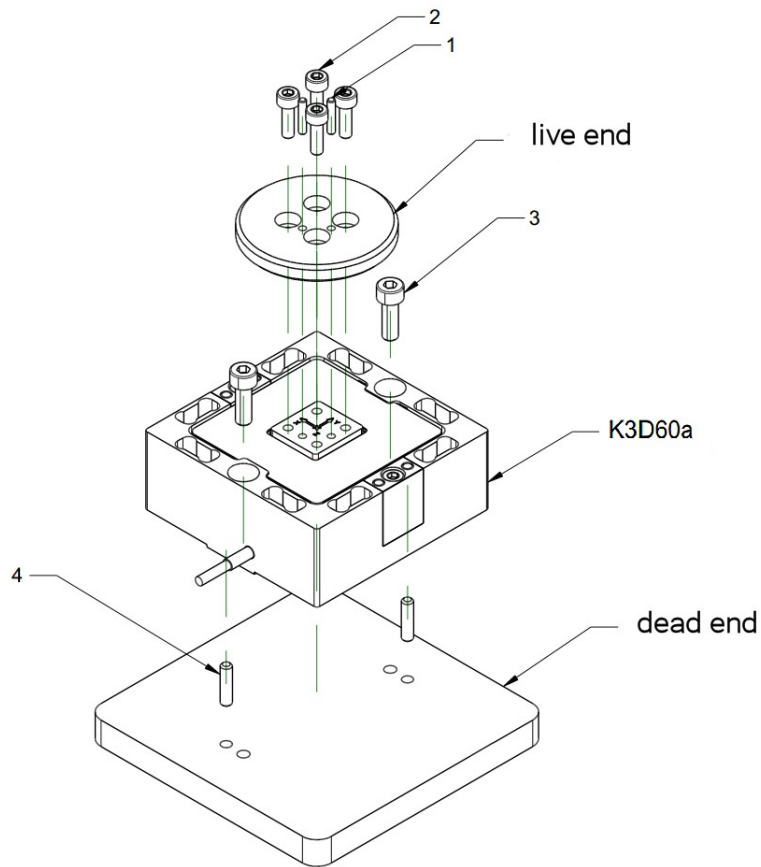

Pos.	Quantity	Designation	Material	Nominal load	Tightening torque (Nm) live end	Tightening torque (Nm) dead end
1	2	Cylindrical pins DIN6325 Ø2m6	Aluminium alloy	±10N ±20N ±50N ±100N	1	2
2	4	Cylindrical head screws DIN EN ISO 4762 M3				
3	2	cylindrical head screws DIN EN ISO 4762 M4	Stainless steel	±200N ±500N	1	2
4	2	Cylindrical pins DIN6325 Ø3m6				



Note:

The distance between sensor body and fastening elements must be 0,75 mm.

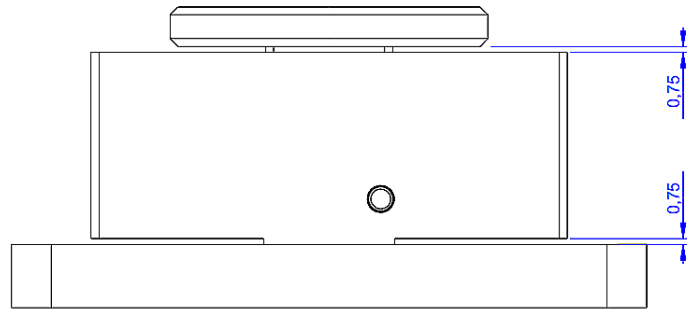

K3D120

Mounting surface:

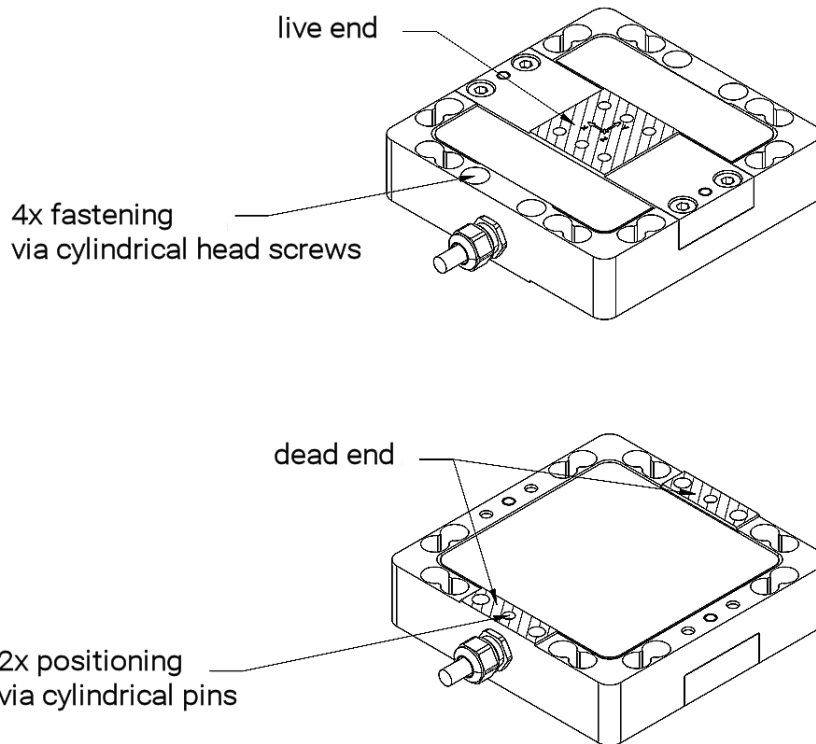

Mounting: live and dead end

The fastening of the measuring construction has to be done on the mounting surface live end / dead end of the K3D sensor. For this, the threads, pin holes and tightening torques specified in the table below must be used. The screw depth in the live end / dead end should be 6-10 mm.

Requirements for mounting surface

- screw depth for thread min. 1.0 up to 1.5 x \emptyset
- high stiffness of the mounting surface, no deformation under load
- flatness of mounting surface 0.05 to 0.1mm
- quality of the mounting surface Rz6.3 \emptyset

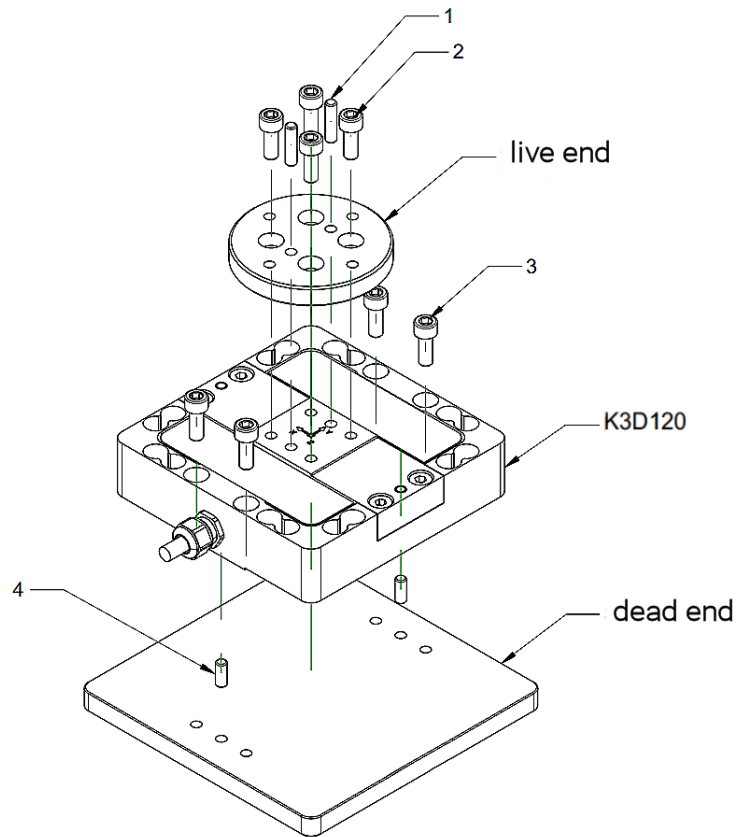

Pos.	Quantity	Designation	Material	Nominal load	Tightening torque (Nm) live end	Tightening torque (Nm) dead end
1	2	Cylindrical pins DIN6325 Ø5m6	Aluminium alloy	±50N ±100N ±200N ±500N ±1kN	10	10
2	4	Cylindrical head screws DIN EN ISO 4762 M6				
3	4	cylindrical head screws DIN EN ISO 4762 M6	Stainless steel	±1kN ±2kN ±5kN	15	15
4	2	Cylindrical pins DIN6325 Ø5m6				



Note:

The distance between sensor body and fastening elements must be 1 mm.

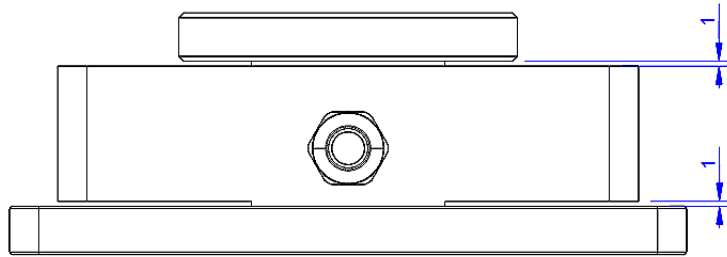

K3D160

Mounting surface:

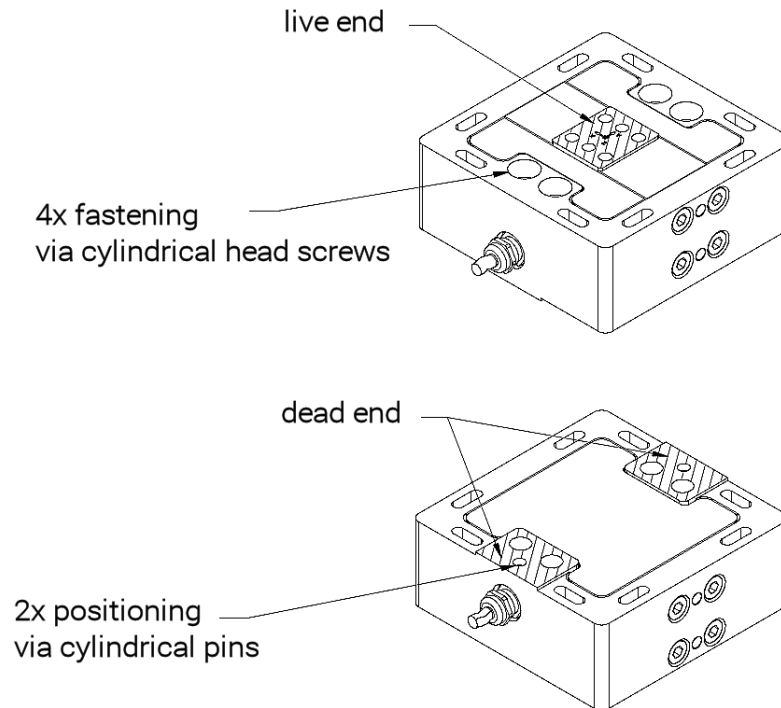

Mounting: live and dead end

The fastening of the measuring construction has to be done on the mounting surface live end / dead end of the K3D sensor. For this, the threads, pin holes and tightening torques specified in the table below must be used. The screw depth in the live end should be 12-15 mm and in the dead end 18-25 mm.

Requirements for mounting surface

- screw depth for thread min. 1.0 up to 1.5 x \emptyset
- high stiffness of the mounting surface, no deformation under load
- flatness of mounting surface 0.05 to 0.1 mm
- quality of the mounting surface Rz6.3 \emptyset

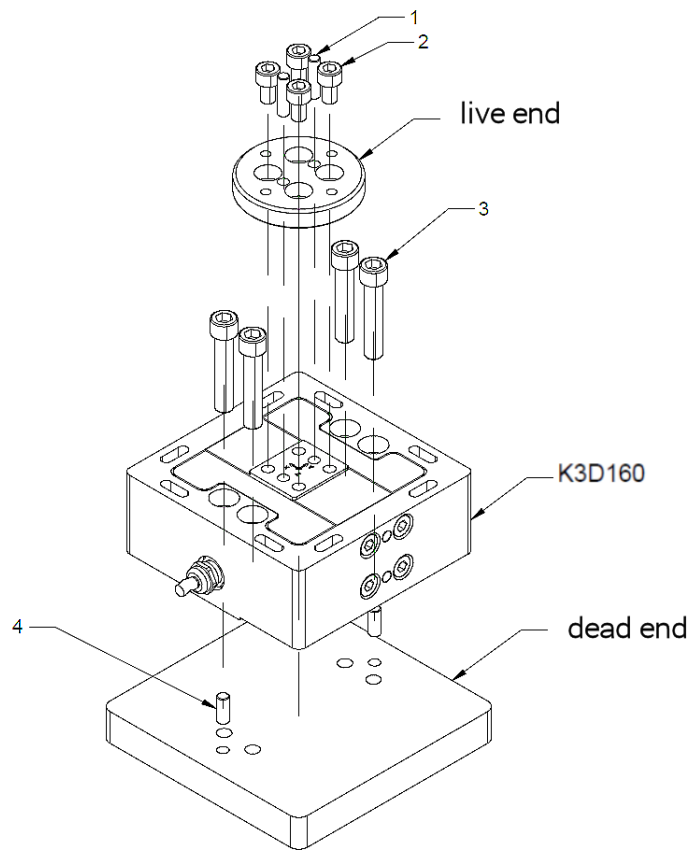

Pos.	Quantity	Designation	Material	Nominal load	Tightening torque (Nm) live end	Tightening torque (Nm) dead end
1	2	Cylindrical pins DIN6325 Ø8m6	Tool-steel	±2kN ±5kN	50	80
2	4	Cylindrical head screws DIN EN ISO 4762 M10				
3	4	cylindrical head screws DIN EN ISO 4762 M12		±10kN ±20kN ±50kN	60	100
4	2	Cylindrical pins DIN6325 Ø8m6				

Note:

The distance between sensor body and fastening elements must be 2 mm.

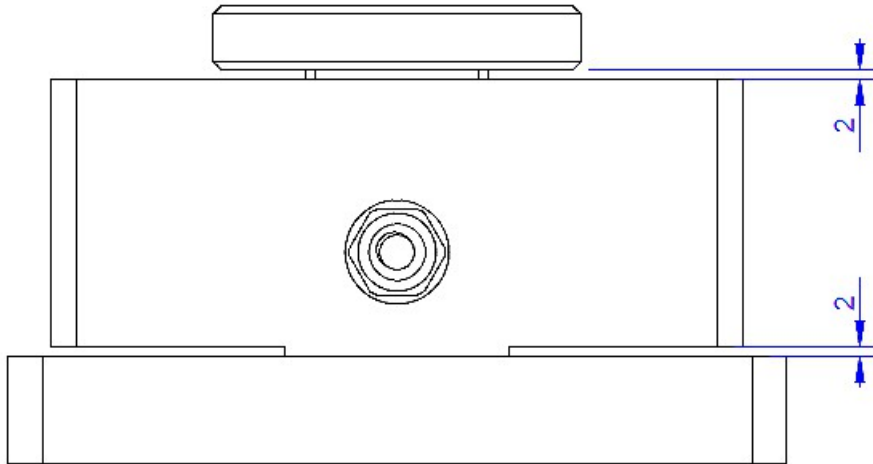

K3D300

Mounting surface:

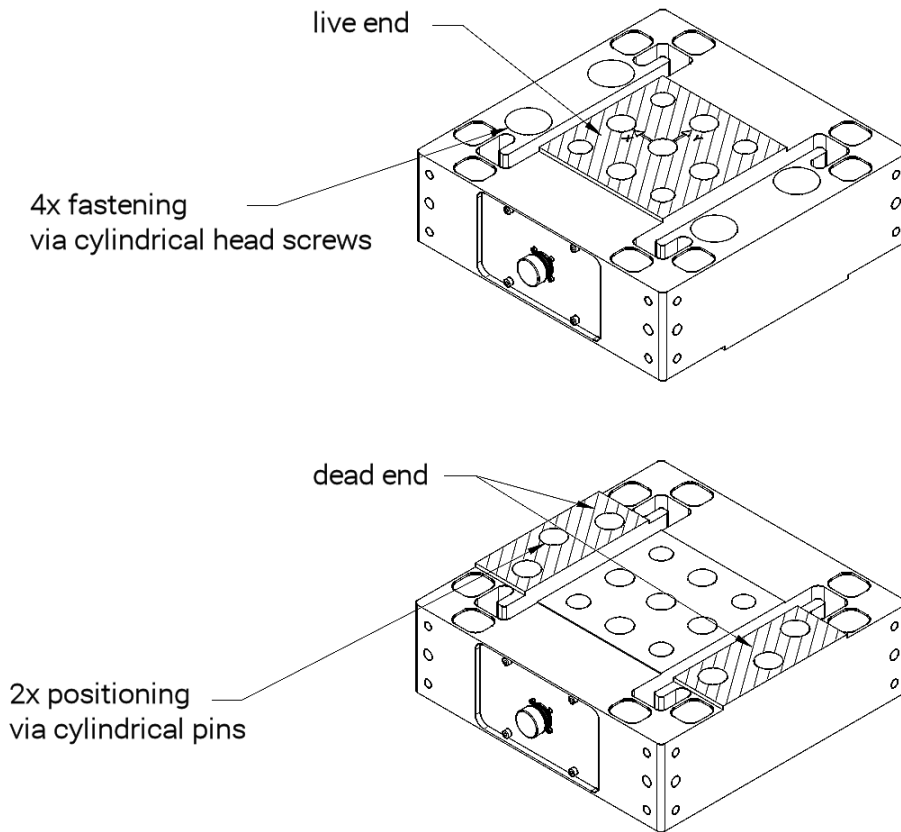

Mounting: live and dead end

The fastening of the measuring construction has to be done on the mounting surface live end / dead end of the K3D sensor. For this, the threads, pin holes and tightening torques specified in the table below must be used. The screw depth in the live end / dead end should be 30-40 mm.

Requirements for mounting surface

- screw depth for thread min. 1.0 up to $1.5 \times \varnothing$
- high stiffness of the mounting surface, no deformation under load
- flatness of mounting surface 0.05 to 0.1 mm
- quality of the mounting surface $Rz6.3\varnothing$

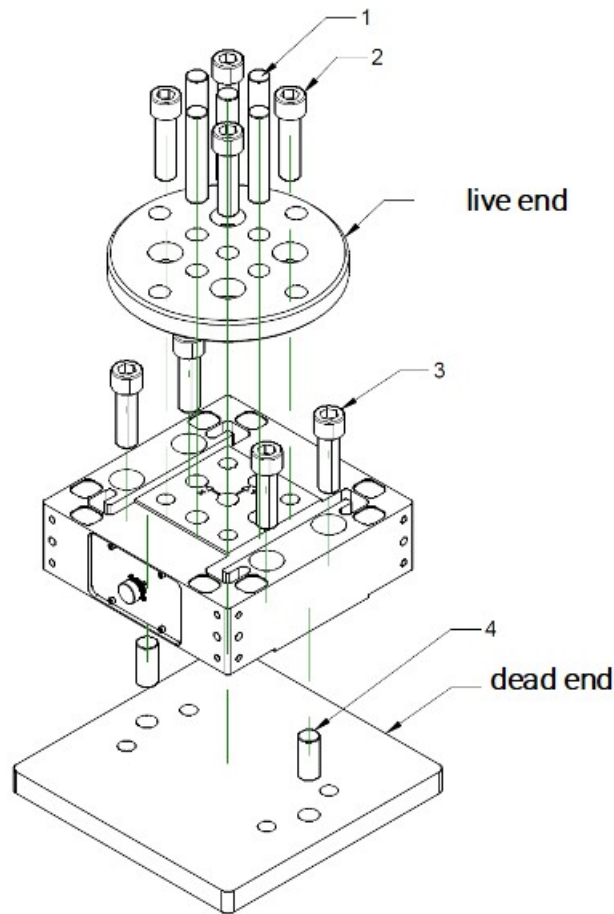

Pos.	Quantity	Designation	Material	Nominal load	Tightening torque (Nm) live end	Tightening torque (Nm) dead end
1	5	Cylindrical pins DIN6325 Ø25m6	Tool-steel	±50kN	500	500
2	4	Cylindrical head screws DIN EN ISO 4762 M24				
3	4	cylindrical head screws DIN EN ISO 4762 M24		±100kN ±200kN	800	800
4	2	Cylindrical pins DIN6325 Ø25m6				



Note:

The distance between sensor body and fastening elements must be 4 mm.

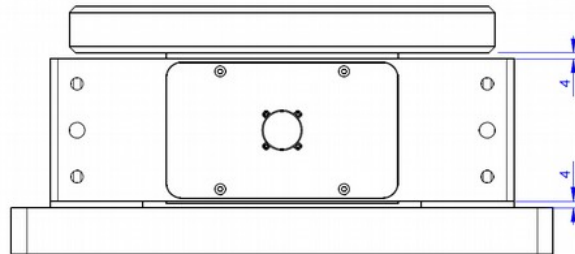

K3D400

Mounting surface:

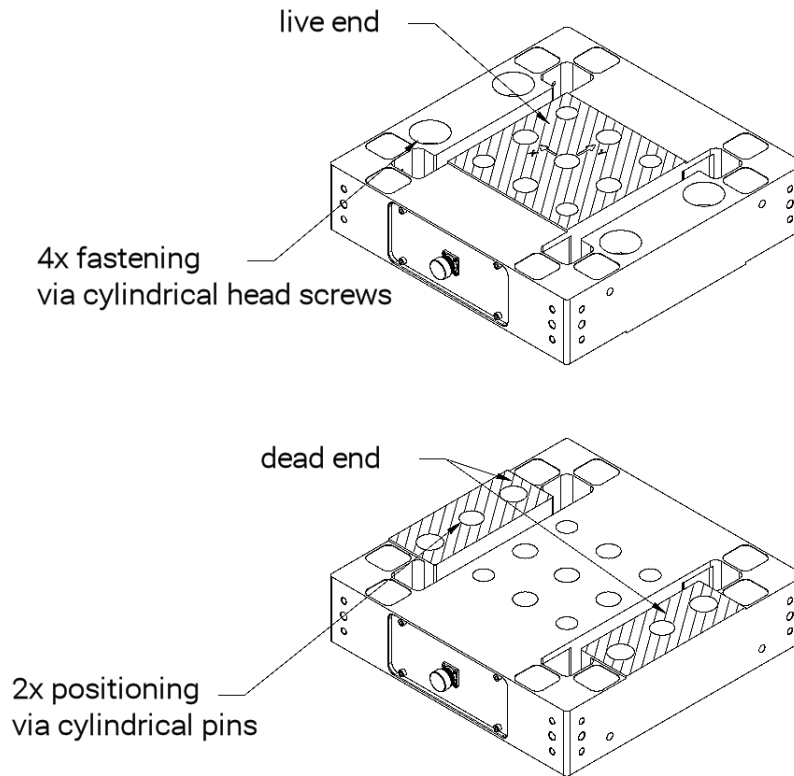

Mounting: live and dead end

The fastening of the measuring construction has to be done on the mounting surface live end / dead end of the K3D sensor. For this, the threads, pin holes and tightening torques specified in the table below must be used. The screw depth in the live end / dead end should be 40-60 mm.

Requirements for mounting surface

- screw depth for thread min. 1.0 up to $1.5 \times \varnothing$
- high stiffness of the mounting surface, no deformation under load
- flatness of mounting surface 0.05 to 0.1 mm
- quality of the mounting surface $Rz6.3\varnothing$

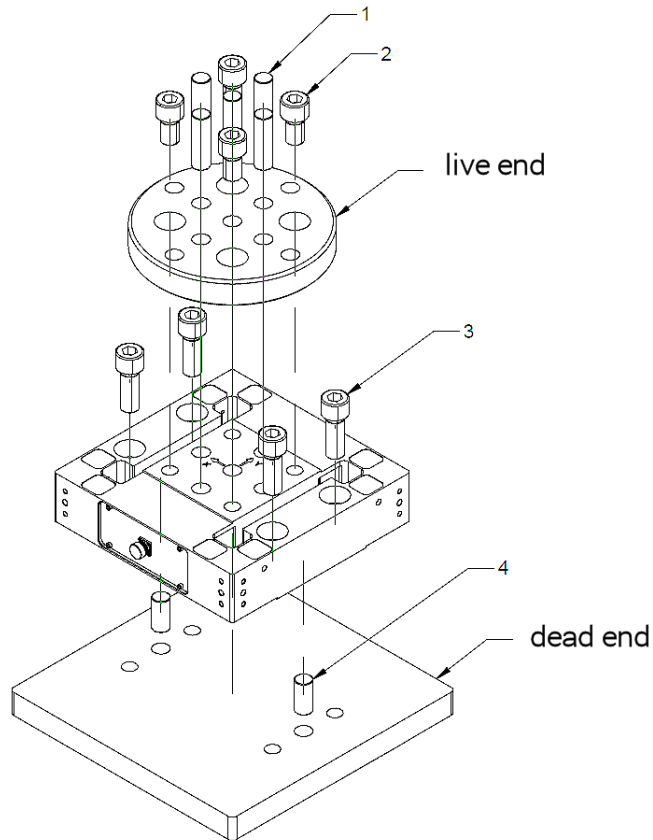

Pos.	Quantity	Designation	Material	Nominal load	Tightening torque (Nm) live end	Tightening torque (Nm) dead end
1	5	Cylindrical pins DIN6325 Ø30m6	Tool-steel	±500kN	1800	1800
2	4	Cylindrical head screws DIN EN ISO 4762 M30				
3	4	cylindrical head screws DIN EN ISO 4762 M30				
4	2	Cylindrical pins DIN6325 Ø30m6				

Note:

The distance between sensor body and fastening elements must be 3 mm.

