

# *Operation Instructions*

## *Torque Transducer*

### *Type DRBK-A*



**Important Advice:**

The torque transducers of type DRBK are suitable for applications in laboratories (for example in testing equipment) as well as in industrial environment.

The torque transducer is not designed with the usual safety factor (2...20), favoring high sensitivity instead.

Pay attention to the overload limit.

You have to protect users from danger of being hurt (metal cover etc.)

The torque transducer is not designed for explosion endangered areas.

Warranty is void if opened or disassembled.

The transducer must only be opened by authorized personnel.

**1. Introduction**

Torque transducers' measurement unit is Nm.

**2. Application**

Torque transducers are able to measure clockwise as well as counter clockwise torque. With clockwise torque the output is positive. The type label indicates the range of the transducer.

The torque transducers measure static torque as precise as dynamic torque. Yet you have to pay attention to the transducer's signal rise time. It is indicated in the Data sheet.

The torque transducers are maintenance-free.

Handle the torque transducer with care, especially when transporting or mounting. Because it can be damaged by hard shocks or by dropping to ground. Even a short peak torque above the allowed overload capacity can damage the measure shaft. In cases where this can happen you have to take precautions to avoid this.

The absolute maximum ratings regarding mechanical, thermal and electric parameters are listed in the data sheet and must be observed in design, mounting and operating.

### 3. Technical Details

#### 3.1 Torque Shaft

The shaft is fixed in the chasing with two ball bearings.

To measure the torque it causes a proportional bending of the shaft (within the elastic range) and this is measured with applied strain gages. The strain gages are connected as a wheatstone bridge. The adhesion is done by suitable coupling at the cylindrical shaft ends. Speed measurement is optionally available. (See the data sheet.)

#### 3.2 Case

The case of the torque transducer is aluminum with a special surface. The mounting of the torque transducer can be done either at foot or flange.

#### 3.3. Measurement

The torque causes the bending of the shaft and the strain gages. The resistance of the strain gages changes proportional to the change of their length. And this is converted into an electrical signal that causes a frequency modulation. This modulated signal is transmitted optically to an electronic circuit in the casing. There it is converted back to a proportional analog output voltage and current. With the optionally speed output, a square wave signal with 60 pulses per revolution is available for further evaluation.

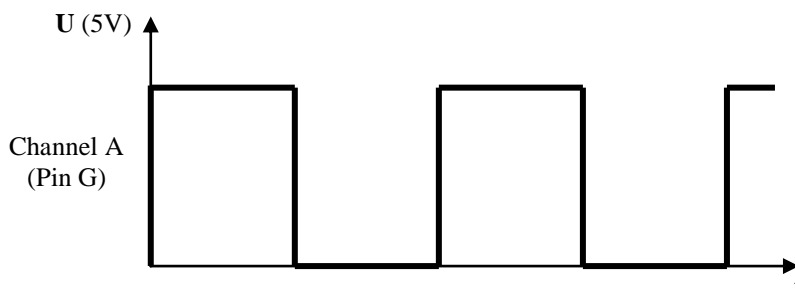

#### 3.4 Disturbances and their Compensation

Avoid bending, axial and radial forces. When you have problems with this, use **ETH** clutches. To connect the transducer to a measurement unit you need a shielded cable.

The transducers are EMC-tested and are complying with  
EN 55011:1998 + A1:1999 + A2:2002  
EN 61326-1:2006-05 and  
EN 61000-6-2:2005.

## **4. Operating Instructions**

### **4.1 Environment Temperature**

For best accuracy you have to meet the environment temperature specification. The temperature should be constant or slowly changing. The specified temperature errors apply only for changes less than 5 K/h. Radiation heat or cooling on one side has to be avoided. Or appropriate precautions have to be taken.

### **4.2 Humidity and Dust**

The torque transducer comply to IP40 after DIN 40050

***Advice: Don't let humidity seep into the transducer's connector!***

### **4.3 Chemically Resistance**

The torque transducers are not resistant against chemicals.

### **4.4 Deposition**

Dust, dirt and other particles mustn't accumulate so that they can get into the ball bearings and the connector.

## **5. Mounting**

### **5.1 Precautions at Assembly**

- \* Handle the transducer carefully
- \* Do not overload the transducer, not even temporarily. If possible, we suggest connecting the transducer to a display unit before mounting, so you can watch the torque while mounting.
- \* Avoid false axial and radial alignment.
- \* Provide good electrical ground contact to the casing.

### **5.2 General Mounting Instructions**

Don't mix up the transducer's drive side and the measuring side, as this causes errors (especially when accelerated).

**When you look at the type label the measuring side is on the left.**

**The measuring side also can be identified by a deepening on the cover.**

Bending, axial and radial forces are causing errors. Keep thermal expanding of the construction in mind.

## 6. Measuring Chain

For measuring with the transducer, a whole measuring chain is necessary.

- \* torque transducer
- \* Measuring cable
- \* Supply and display unit (e.g. SPC)

You need a supply and display unit to supply the transducer with power and to display the measured torque.

## 7. Connection

### Connection of a torque transducer

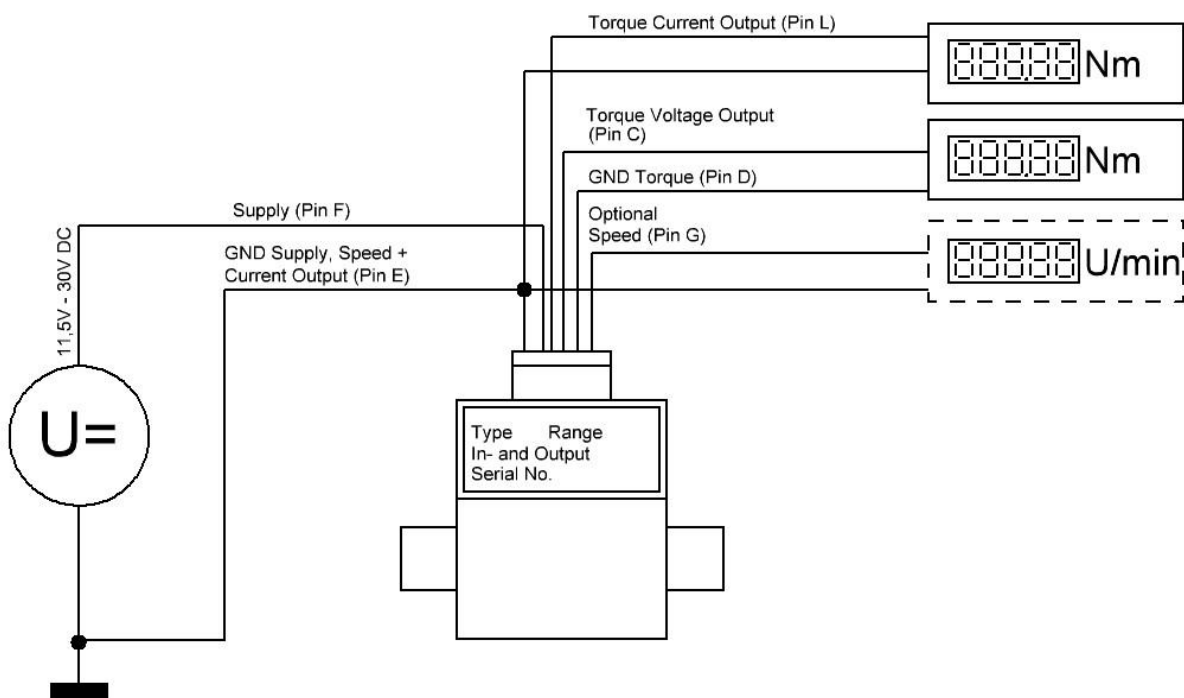

## **7.1 Hints for connection**

Electric and magnetic fields cause interference with the measuring signal. This interference is mainly caused by power cords, relays or motors installed nearby. Besides these, interference can be caused by multiple grounding of the measurement chain on more than one point.

Pay attention to the following:

- \* Use only shielded cables with low capacitance (like our measuring cables).
- \* Connect supply voltage correctly (no reverse polarity protection).
- \* Measuring cables shouldn't be nearby high voltage or control cables.
- \* Magnetic radiation from transformers, motors or relays must be avoided.
- \* Don't ground transducer and display unit multiple. Connect all devices of the measurement chain to the same ground.

## **7.2 Connector**

The transducer is equipped with a 12 pin fitted connector type Binder.

## **7.3 Pinout of the Connector**

The pinout of the connector is showed on the next page.

## **7.4 Prolongation of Cable**

Prolongation cables have to be shielded and of low capacity. We recommend the use of our cables.

Good electrical connection of the prolongation cables is essential. It is important to use a cable with sufficient diameter so that the voltage drop on the supply lines isn't too high.

For a long distance we recommend you to use the current output of the transducer.

## Pin Configuration

Torque transducer (with option speed sensing)

**Connector: 12 pin**

### Model DRBK(-n)

Pin	Connection	Colour (ETH measurement cable with flying leads)	
		AK12.2F	AK12.2DF (double shielded)
A	NC	Black	Brown
B	NC	Red	Brown/Green
C	Torque Voltage Output	Brown	Yellow
D	GND Voltage Output	White	White
E	GND Supply, Speed+ Current Output	Yellow	Black
F	Supply	Violet	Red
G	Speed (optionally)	Green	White/Green
H	NC	Pink	Pink
J	NC	Grey	Blue
K	NC	Grey/Pink	Grey
L	Moment Current Output	Blue/Red	Green
M	Shield	Blue+shield	Violet

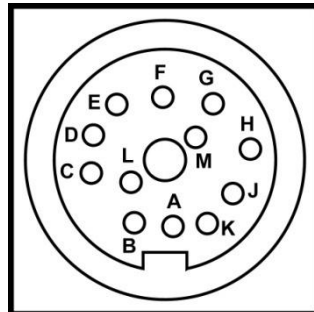

(Connector at the transducer, view from above.)

## 8. Output

The transducer's output is a proportional voltage of 0  $\pm$ 5V and a current of 10  $\pm$ 8mA.

With clockwise torque the output is positive; with counter clockwise torque the output voltage is negative.

The outputs for rotation speed and angle measurement have an open collector stage, with an internal 10 K $\Omega$  pull up resistor in series with a diode. See schematic below.

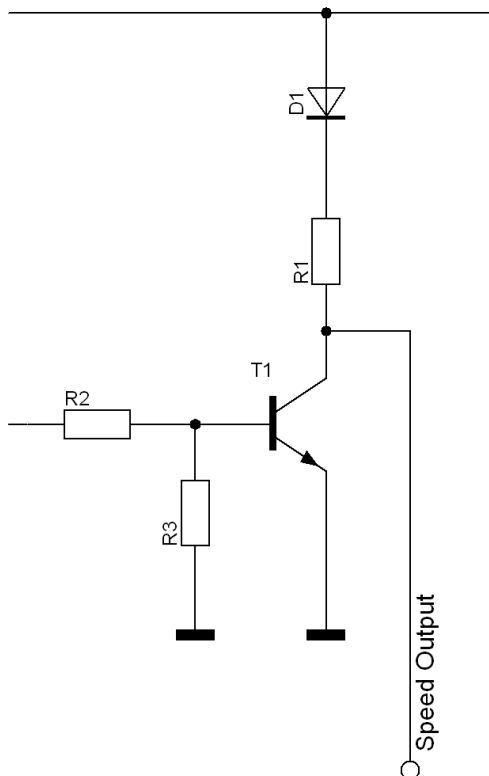

With this circuit you can measure speed of **more than 15,000 RPM** and with a cable of **up to 33 ft.**

The signal level of the circuit on the left hand side is suitable for opto couplers, frequency counters, oscilloscopes and for (H)CMOS logic. If you need standard TTL levels you can add the circuit on the right hand side.

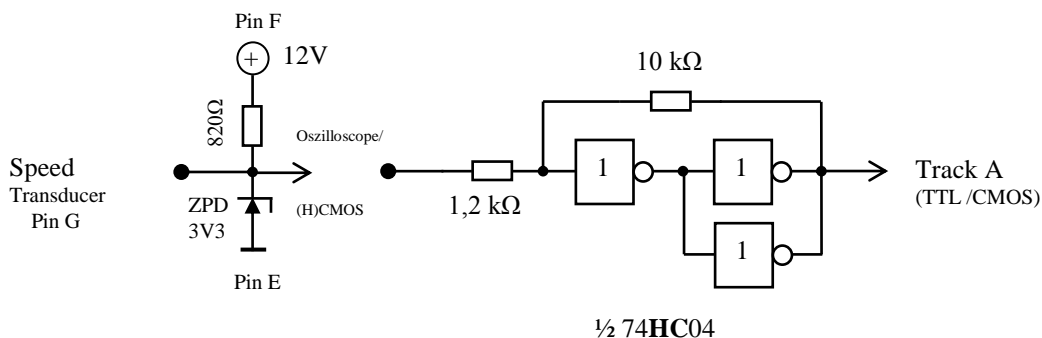



## 9. Display functions



The rated torque is always resolute in 4 digits. I.e. on a rated torque of 200Nm a value would be displayed as „200.0Nm“. The value gets actualized every 100ms.

The revolution speed is displayed as an integer. The allowed range lies between 0 and 32000rpm. The value gets actualized every second.

After a power cycle the transducer is always in track mode (LED off). To change the display mode, push the “PEAK/TRACK” button. In peak mode the LED below the display is on. The peak mode shows the maximum clockwise torque, above 5% of the rated torque. Values below 5% of the rated torque will not be shown, the Value will be 0.

In track mode the “TARE” button tares the display, if the absolute torque value is smaller 5% of the rated torque.

In peak mode, the tare button deletes the peak value.