

- ▶ Triaxial
- ▶ IEPE (Integrated Electronic Piezoelectric)
- ▶ Titanium Housing
- ▶ Voltage Output

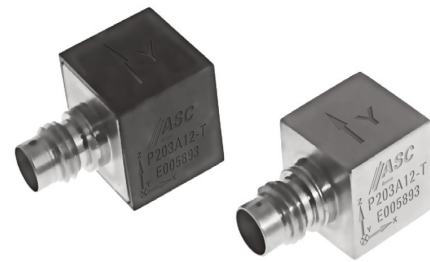

ASC P203A11

ASC P203A12



Features

- ▶ $\pm 50g$, $\pm 100g$, $\pm 500g$ and $\pm 2000g$ Dynamic Ranges
- ▶ Miniature Cube (6 grams)
- ▶ Wide Bandwidth (9kHz)
- ▶ Hermetically Sealed
- ▶ $-55^{\circ}C$ to $+125^{\circ}C$ Operating Range
- ▶ Shear Design
- ▶ TEDS

Options

- ▶ Case-Isolated Version (ASC P203A11)
- ▶ Customised Cable Length
- ▶ DAkKS Calibration

Applications

- ▶ Modal Analysis
- ▶ Automotive Testing
- ▶ Laboratory Testing
- ▶ General Purpose Vibration & Shock Monitoring
- ▶ Test & Measurement Applications
- ▶ High-Frequency Applications
- ▶ Structural Analysis Measurements

Piezoelectric IEPE Technology

ASC's Miniature Triaxial IEPE accelerometers are made of piezoelectric ceramics and are usable over a wide frequency range from 1Hz to 9kHz. The triaxial accelerometer is an IEPE (Integrated Electronics PiezoElectric) sensor that produces three simultaneous output voltages proportional to the input accelerations along X-, Y- and Z- axis. The sensor features three independent amplifiers that transform the high-impedance charge output from the piezoelectric ceramics (Lead Zirconate Titanate, PZT) into low-impedance voltage output that is suitable to drive long cables. ASC's miniature IEPE triaxial accelerometer operates on a 2-10mA constant-current supply and uses a four-wire cable for power input and signal output. The triaxial design incorporates three PZTs in annular shear mode where all three axes work independently, enabling single axial supply. This supply option provides the flexibility to power only one or two axes during uniaxial or biaxial measurements.

Description

ASC Type P203A12 is an analog voltage output sensor, which is designed for applications that demand compact triaxial sensors. The miniature size of this triaxial accelerometer enables simultaneous measurement of accelerations along three orthogonal axes of vibration on light-weight structures. The sensor is based on a piezoelectric annular shear design, which provides excellent immunity against base strain and temperature transients.

ASC Type P203A12 features a rugged titanium housing that is light-weight, corrosion proof and chemical resistant. ASC Type P203A12 operates over a wide temperature range from $-55^{\circ}C$ to $+125^{\circ}C$. The sensor incorporates a welded hermetic construction and can withstand shocks up to 5000g's. The industry standard 4-pin Microtech connector with side exit provides flexibility in mounting.

ASC Type P203A11 is the case-isolated version, with anodised aluminium alloy isolation cover. Both sensors feature built-in TEDS.

ASC P203A11

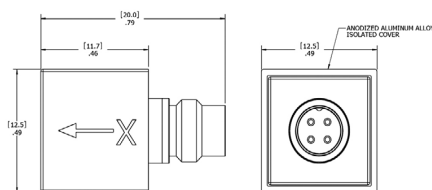

ASC P203A12

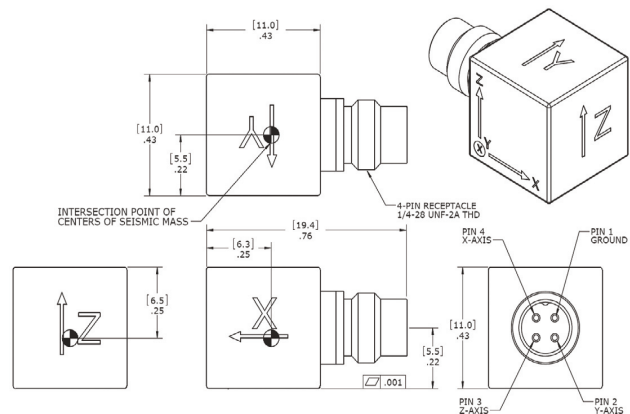

Typical Specifications

MODEL NUMBER: ASC P203A11 / ASC P203A12

Type: Piezoelectric IEPE Miniature Triaxial Accelerometer

DYNAMIC		Range (\pmg)			
		50	100	500	2000
Sensitivity (\pm 15%)	mV/g	100	50	10	2.5
Full Scale Output	V	\pm 5			
Amplitude response: (\pm 10%)	Hz	2.5 to 8k	1.5 to 8k	1 to 8k	1 to 9k
Phase response: (\pm 10°)		1 to 9k			
Non-linearity	%FSO	\pm 1			
Resonance Frequency	kHz	43			
Transverse sensitivity (Max.)	%	<5			
Shock limit	\pm g	5000 (half-sine, 300 μ s)			
Output Polarity		Acceleration in the direction of the arrow (see outline drawing) generates a positive output			

ELECTRICAL

Excitation voltage	V DC	18 to 30			
Supply current	mA	2 to 10			
Bias Voltage	V DC	10 \pm 2 (room temperature) 10 \pm 4 (in full temperature range)			
Output Impedance	Ω	<100			
Isolation		ASC P203A11: Case Isolated ASC P203A12: Case Grounded			
Startup time (to 90% of bias)	sec	1			
Spectral Noise	μ g/ \sqrt Hz	1Hz: 220; 10Hz: 90; 100Hz: 30; 1kHz: 15			
Broadband noise (1Hz to 10kHz)	milli g	0.4	0.5	1.2	3.2

ENVIRONMENTAL

Temperature coefficient of sensitivity (A: -55°C to +80°C) (B: +80°C to +125°C)	%/°C	A: +0.05; B: -0.05			
Thermal Transient Sensitivity	mg/°C	0.5			
Operating & Storage temperature range	°C	-55 to +125			
Sealing		Hermetic			

PHYSICAL

Sensing element / design		PZT / Shear			
Case material		Titanium			
Connector		4-pin Microtech			
Mounting		Adhesive / Stud mount			
Mounting thread		M2.5 x 0.45			
Weight (without cable)	gram	ASC P203A11: 7.3 ASC P203A12: 6			
Cable		4-pin, 1/4"-28 to 3xBNC Low-noise TPE			

Note: 1g = 9.80665m/s²

FACTORY CALIBRATION (SUPPLIED WITH THE SENSOR)

Range	50g	100g	500g	2000g
Sensitivity	at 160Hz and 10g	at 160Hz and 15g	at 160Hz and 25g	
Frequency Response	10Hz to 8kHz		10Hz to 9kHz	

CALIBRATION DIN ISO 17025 (ORDER SEPARATELY)*

Range	50g	100g	500g	2000g
Frequency Response	I: 1Hz to 100Hz (Long-stroke shaker calibration) II: 10Hz to 9kHz (High-frequency shaker calibration)			

ORDERING INFORMATION

ASC P203A1Y	T	XX
Sensor Type	TEDS	Range
ASC Triaxial miniature IEPE accelerometer		51 ±50g
Y: 1 (Case isolated version; anodized aluminium isolation cover)		12 ±100g
Y: 2 (standard version; titanium housing)		52 ±500g
		23 ±2000g

Example: ASC P203A12-T52

ACCESSORIES

Cable Assembly for ASC Triaxial IEPE Accelerometers	
KPT	XXX
	Cable length in meters
Cable for Triaxial IEPE Accelerometers	
4-pin Microtech to 3x BNC	003: 3m
-55°C to +125°C	006: 6m
	009: 9m

QUALITY

- 1) ASC is ISO 9001:2015 certified
- 2) The Deutsche Akkreditierungsstelle GmbH (DAkkS) has awarded to our calibration laboratory the DIN EN ISO/IEC 17025:2005 accreditation for calibrations and has confirmed our competence to perform calibrations in the field of mechanical acceleration measurements.

* accredited by the German accreditation body (Deutsche Akkreditierungsstelle, DAkkS) to DIN EN ISO / IEC 17025; the pictured DAkkS-ILAC logo refers exclusively to the accredited service