

K3R70 $\pm 50\text{N}/500\text{mNm}$



Description

The force sensor K3R70 is suitable for inspection tasks in quality assurance as well as in materials testing because of its compact design. This precision force sensor is characterized by flat design of only 12 mm thickness.

The axial force F_z and the bending moments M_x and M_y are calculated from the strain gage signals of the 4 cantilever springs.

With the aid of a simple calibration matrix the forces and distances can be calculated as well.

Dimensions

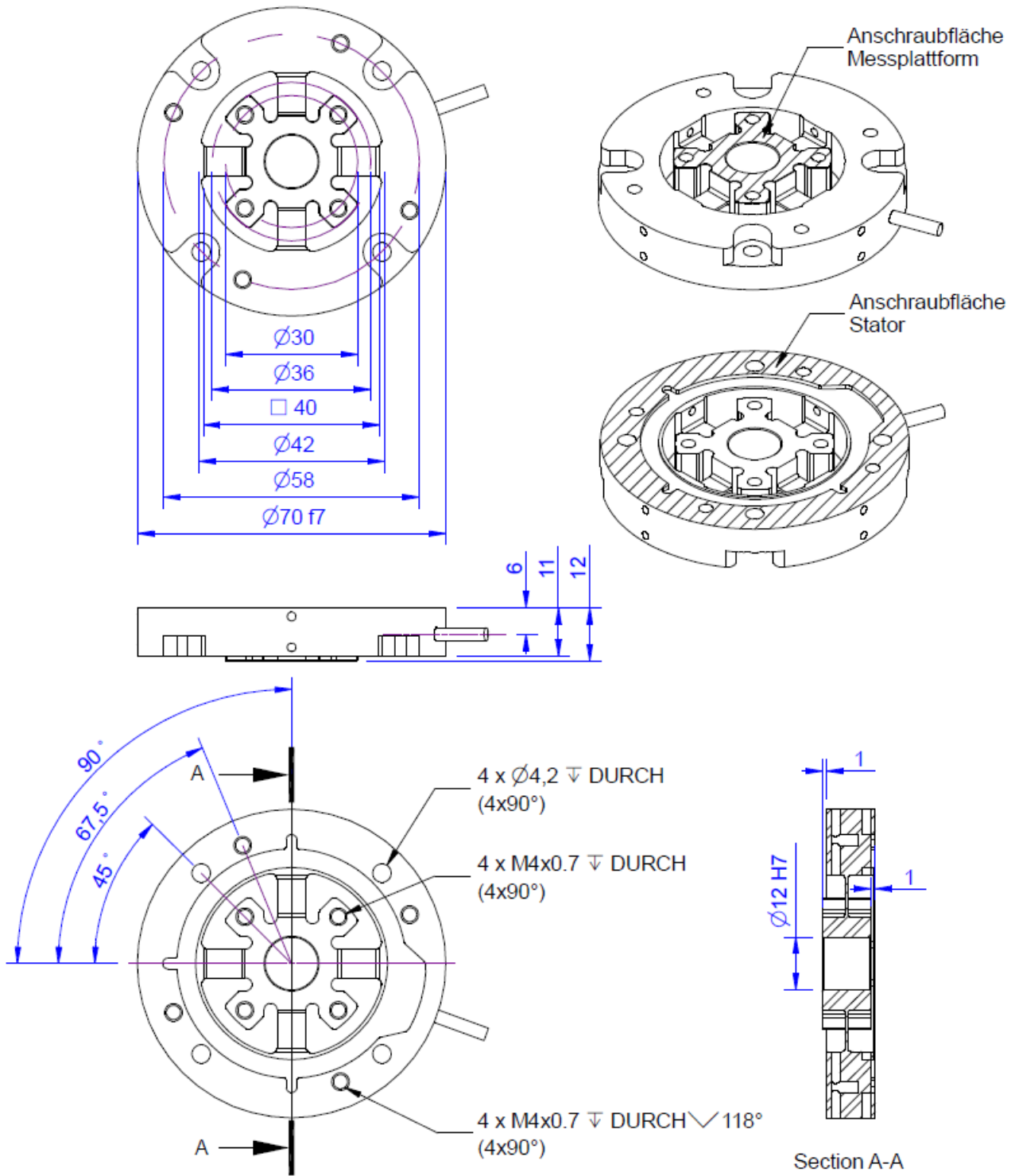

Technical Data

Force sensor

Type	3-axis force sensor
Force direction	Tension / Compression
Rated force Fz	50 N
Force introduction	Inner thread
Dimension 1	4x M4x0,7
Sensor Fastening	Inner thread
Dimension 2	4x M4x0,7
Operating force	150 %FS
Rated displacement	0.1 mm
Material	Aluminium alloy
Dimensions	Ø 70 x 12 mm x mm
Height	12 mm
Length or Diameter	70 mm
Rated torque Mx	500 mNm
Rated torque My	500 mNm
Torque limit	200 %

Electrical Data

Input resistance	87 Ohm
Tolerance input resistance	2 Ohm
Output resistance	350 Ohm
Tolerance output resistance	5 Ohm
Insulation resistance	2 GOhm
Rated range of excitation voltage f	2.5 ... 5 V
Operating range of excitation voltage f	1 ... 5 V
Zero signal	0.05 mV/V
Rated output	1 mV/V / FS

Precision

Accuracy class	0,1%
Relative linearity error	0.1 %FS
Relative zero signal hysteresis	0.1 %FS
Temperature effect on zero signal	0.01 %FS/K
Temperature effect on characteristic value	0.01 %RD/K
Relative creep	0.1 %FS

Connection Data

Connection type	10-Leiter offen
Name of the connection	ME-SYSTEME.DE / 30-12 PUR / 12x0,061mm ²
Cable length	3 m

Temperature

Rated temperature range f	-10 ... 70 °C
---------------------------	---------------



Operating temperature range f	-10 ... 85 °C
Storage temperature range f	-10 ... 85 °C
Environmental protection	IP66



Abbreviation : RD: „Reading“; FS: „Full Scale“;

1) The exact rated output is reported in the test report .

Pin Configuration

Channel	Symbol	Description	Wire colour
1	+Us	positive bridge supply	brown, orange
	-Us	negative bridge supply	white, transparent
	+Ud	positive bridge output	green
	-Ud	negative bridge output	yellow
2	+Us	positive bridge supply	brown, orange
	-Us	negative bridge supply	white, transparent
	+Ud	positive bridge output	grey
	-Ud	negative bridge output	pink
3	+Us	positive bridge supply	brown, orange
	-Us	negative bridge supply	white, transparent
	+Ud	positive bridge output	blue
	-Ud	negative bridge output	red
4	+Us	positive bridge supply	brown, orange
	-Us	negative bridge supply	white, transparent
	+Ud	positive bridge output	black
	-Ud	negative bridge output	purple

accessories

Description	Description
	K3R-CalibrationMatrix Calibration matrix with 12 calibration factors for scaling of the sensor output signals on forces Fz and moments Mx and My.
	GSV-8DS 8-channel amplifier with USB port, analog output, UART interface. Other versions GSV-8AS CAN with Canbus and GSV-8AS EC with EtherCAT fieldbus.
	Configuration D-Sub44/m/HD Assembling the connector to sensor cable; Connector Type SubD, 44 pins, male (male), with hood