



# Clamping Battery Telemetry Model: CBT-mini

## Installation Manual



Copyright © 2020 Michigan Scientific Corporation

Details and specifications provided in this document are purely for informational purposes and are subject to alterations. No liability is accepted for errors or omissions.

Michigan Scientific Corporation  
8500 Ance Road  
Charlevoix, MI 49720  
(1-231-547-5511)  
michsci.com

Revision A2: 03/23/2022 7:30 a.m. twnachazel

# Contents

Introduction	4
System Overview	6
Full System	6
Telemetry System Schematic	6
CBT-mini transmitting unit	7
Batteries	7
M540 Transmitter	8
M540 Receiver	8
Power Cable	9
Receiving Antennas	9
Signal Output Cable	10
System Set-Up	11
Strain Gauge Bridge Connection	11
Install Batteries	11
Install CBT-mini on Shaft	12
Power Switch and Shunt Sequence	13
Transmitter Full Scale and Shunt	13
Receiver Box Set-up	14
Analog Signal Output Cable	16
Sensitivity (Shunt Calibration)	17
Appendix	18
System Troubleshooting	18
Mounting	19
CBT Mounting	19
Required Tools	19
Full System	19
Mounting Location	20
Mounting	21

## Clamping Battery Telemetry-mini

- Clamps to any shaft 25 mm (1.00 inch) or larger
- Small package
- One strain gauge bridge channel
- Up to 28 hours of battery life
- Lightweight rugged IP67 housing
- Digital 2.4 GHz RF link for reliable transmission without interference or spikes

## Specifications

RF Frequency Range	2.4 GHz
Channel Type	Strain Gauge, Full Bridge, 350 $\Omega$ or higher
Channel Count	1
Power	Transmitter: Two CR123a 3.3-Volt lithium Batteries Receiver: 9-36 VDC, 1A max. each
Continuous Battery Life	28 hours for non-rechargeable. 15 hours for re-chargeable
Weight	145 grams (181 grams with batteries installed)
Gain Type	Fixed gain
Input Type	0.1 mV/V to 10 mV/V
Shunt Resistor	Fixed 100 k $\Omega$ standard, other shunt resistor values available
Typical Broadcast Distance	3 m to 4 m, line of sight
Channel Sampling Rate	7 kHz
Signal Output	$\pm$ 10 Volt Analog
System Resolution	14 Bit
Operating Temperature	Transmitter: -40°F to 158°F (-40°C to 70°C) Receiver: -20°F to 160°F (-30°C to 70°C)
Power Requirement	9 Vdc to 36 Vdc, 4.5 W
Total System Delay	<200 $\mu$ s
RF Channels Available	16
Output Signal	$\pm$ 10 Volt Maximum
Data Bandwidth	Low-pass 2-pole Bessel, Factory set at 1000 Hz, (100 Hz optional)

# System Overview

The CBT-mini System is comprised of the following components: CBT-mini transmitting unit, M540 Receiver, two receiving antennas, receiver power cable, and receiver signal output cable.

## Full System

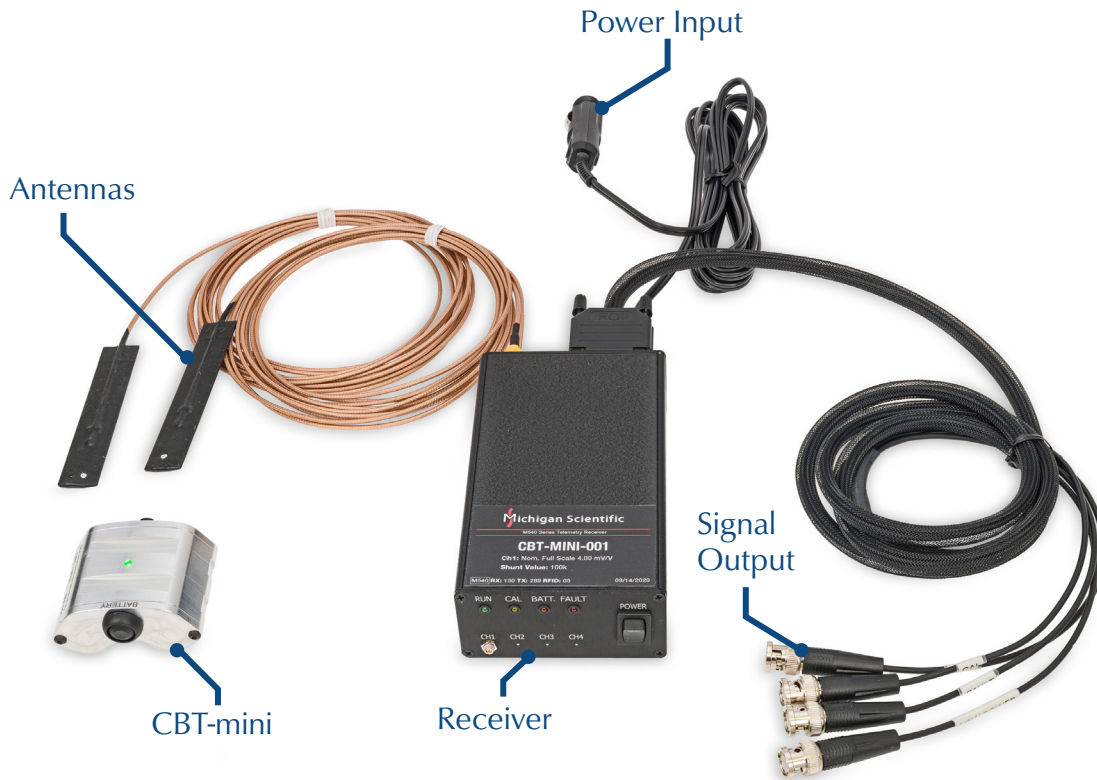

## Telemetry System Schematic

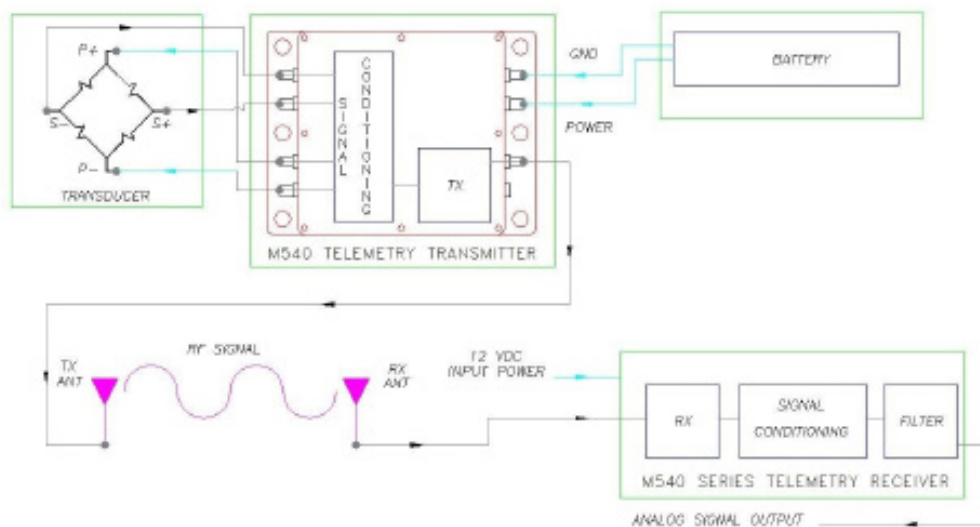

## CBT-mini transmitting unit

The CBT-mini transmitting unit contains a Michigan Scientific M540 Series Digital Telemetry Transmitter, two CR123a batteries, an On/Off switch, a power indicating LED, and an input connector. The M540 Transmitter conditions low level strain gauge bridge signals, transmits signals wirelessly, and ultimately provides a high level analog voltage signal for recording. The two CR123a batteries wired in series provide power to the Telemetry Transmitter. The On/Off switch turns on the Transmitter, when the switch is depressed. The LED indicator turns on when the transmitter has power. The input connector is for connection to a full strain gauge bridge.



## Batteries

Each CBT-mini transmitting unit is powered by two CR123a batteries. These are available in Lithium metal (non-rechargeable) and Lithium Ion (rechargeable) packages. Both battery packages are available on Amazon. With Lithium Metal 1550 mAh batteries, 28 hours of battery life is expected. With Lithium Ion (rechargeable) 800 mAh batteries, 15 hours of battery life is expected.



## M540 Transmitter

The M540 transmitter includes a strain gauge driver, amplifier, and anti-alias filter within the signal conditioning block. It sends the bridge output signal (measured across S+ to S-) via radio frequency (RF). The RF carrier transmits the digital data. Each time the power is switched on to the transmitter, a 3-second-long shunt calibration sequence is initiated. This is the best way to set-up strain gauge bridge sensitivity. This will be explained in more detail on page 13.



## M540 Receiver

After detection by a receiving antenna, the digital signal is converted to a high level analog signal by the Receiver. A jumper selectable low-pass filter in the receiver provides data output bandwidths of either 100 Hz or 1000 Hz. The system shipped to you has been set at the factory for a bandwidth of 1000 Hz.



## Power Cable

The Receiver must be powered by a DC power source between 10-36 Volts. A cigarette plug power cable is provided.



## Receiving Antennas

Two receiving Antennas are provided with the system. For best reception, use both antennas and place them on opposite sides of the shaft from each other.



## Signal Output Cable

A signal output cable is provided which mates to the 15 pin D-sub connector on the back of the receiver. The Signal output cable has four BNC connectors. The connectors are labeled: CH1, FAULT, LOW POWER, & CAL.



CH1: Channel 1, which is the strain gauge bridge connected to the CBT-mini

The remaining 3 signals are diagnostic signals.

FAULT: RF Fault (loss of telemetry signal)

LOW BATTERY: Indicates low battery or insufficient power to transmitter

CAL: Indicates an active Shunt Calibration Sequence

# System Set-Up

## Strain Gauge Bridge Connection

Wire your full 350 Ohm strain gauge bridge to the provided Deutsch connector that mates with the CBT-mini. Proper wiring to the strain gauge bridge is shown below.

Pin #	Deutsch conn (6S)	Transmitter
1	Red	P+
2	Green	S+
3	White	S-
4	Black	P-



## Install Batteries

Install two CR123a batteries as shown below. The battery lid can be removed with Allen wrench. The transmitter lid (connector side) should not be removed.



## Install CBT-mini on Shaft

CBT-mini can be installed with metal hose clamps, load rated plastic ties, or even taped to the shaft. Attachment method depends on shaft speed and diameter. Consult with Michigan Scientific on appropriate installation for shaft diameter and speed. After CBT-mini is secure, the strain gauge wires should also be secured with adhesive or tape.

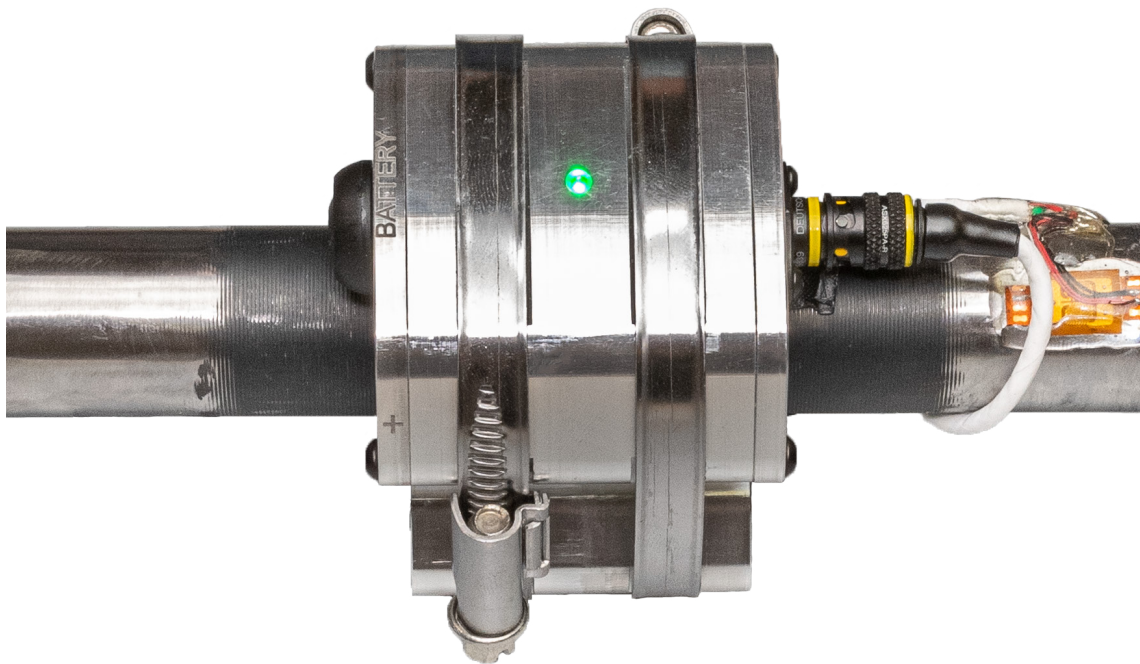

## Power Switch and Shunt Sequence

Depress the power switch to turn on power to the Telemetry Transmitter. The green LED should illuminate. Immediately Upon power up a 3 second Shunt Sequence is initiated. The Shunt Sequence can be used to set-up sensitivity of your strain gauge bridge.



## Transmitter Full Scale and Shunt

The Telemetry Transmitter Gain and Shunt are fixed in the transmitter. The nominal full scale and Shunt calibration resistor value for your



system can be found on the Receiver label, like the one below.

## Receiver Box Set-up

The receiver box should be placed in an area protected from the weather. The power cable and the antenna cables need to connect to the rear panel. It is important for the receiver to have adequate ventilation.

Plug the antenna coax into the appropriate connector on the back panel of the receiver box. With the transmitter off, power-on the receiver. The front panel RF FAULT LED should be lit. Now turn on the transmitter and mount the antenna as close to the CBT-mini as practical. It is usually better to position the antenna away from large bodies of metal that will weaken or block the transmitted and received RF signals. The RF FAULT LED on the front panel of the receiver box will help determine the best antenna position and orientation during installation. RF FAULT LED on is bad, off is good. Some experimentation with antenna location and orientation will be needed to obtain the best signal as indicated by the RF FAULT LED.

Each receiver can accept two receiving antennas. The receiving radio listens to both inputs and selects the input with the best reception. Receiving antennas should be in different locations, ideally 180 degrees apart.

There is an RF FAULT LED on the front panel of the receiver box. The FAULT LED will light to indicate to the user any faults in the received RF signal. The receiver checks each transmission from the transmitter. If a fault is detected, the LED is turned on. When the power to the transmitter is off, the FAULT LED is on constantly.

The BATT LED on the front panel will light when the Voltage from the batteries is too low. When this LED is lit, replace the batteries in the CBT-mini.

The CAL LED will be lit when the transmitter is in the start-up calibration sequence. This calibration sequence lasts for approximately three seconds immediately after the transmitter is powered. Additional information on the calibration sequence can be found below.

The front panel has a zero adjustment potentiometer. This potentiometer can be used to adjust for minor zero offset at zero load. To use, first insure that there is zero torque applied to the strain gauge bridge or transducer. With a voltmeter connected to the CH 1 output connector, adjust the voltage output level to zero by turning the potentiometer. You may also monitor your data acquisition system, and after putting the transducer in a zero torque condition, Zero your data acquisition equipment.

During operation, it is not uncommon to observe some flickering of the RF Fault LED. If the receiver detects a fault, the output D/A converter in the receiver holds the last valid sample. The sample rate for each transmitter is approximately 3000 samples per second.

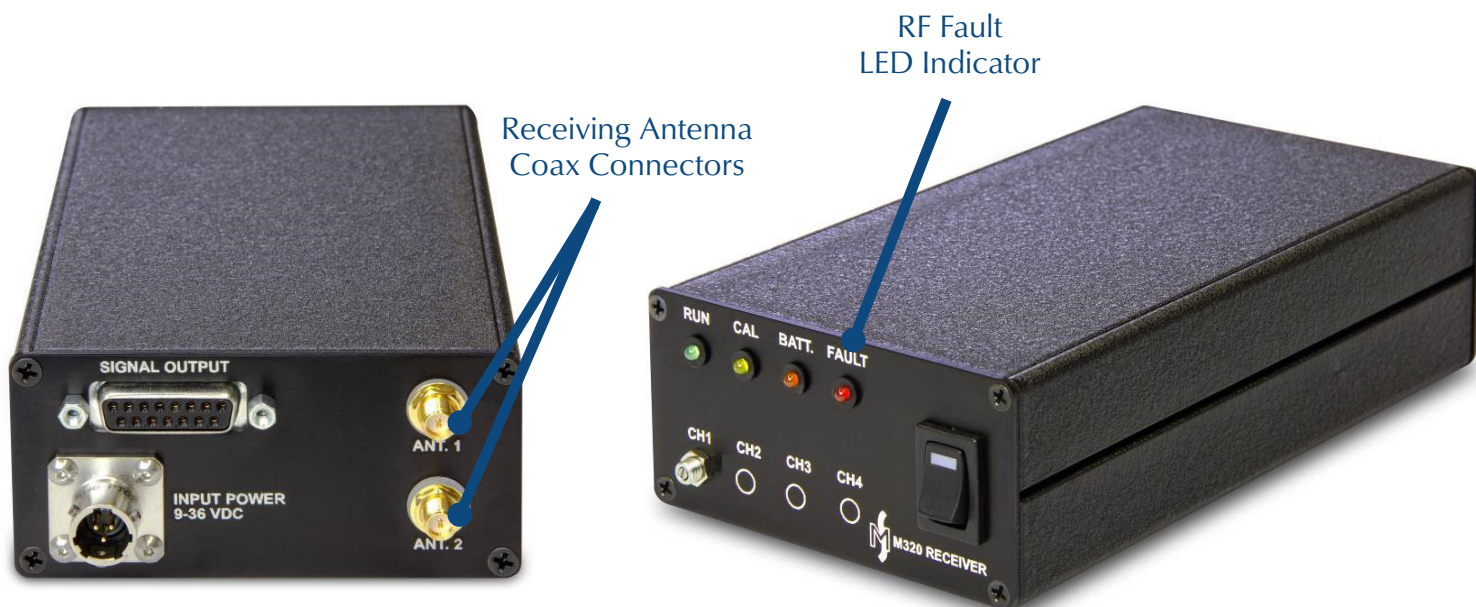

## Notes

There is NO provision for zeroing the transducer bridge at the transmitter. If the bridge unbalance is too high (above about 5% of full scale), the strain gauge bridge can be padded with a resistor across one arm.

## Analog Signal Output Cable

Each receiver has its own analog signal cable. Analog signals are output on BNC connectors. The connectors are labeled and a brief description of each signal is given below:



- CH1: Channel 1 analog output.  $\pm 10$  V. Half Shaft Torque Channel.
- CAL: On (1.8 V) during start up calibration sequence. Off (0 V) otherwise.
- LOW POWER: Low battery indicator. When the batteries reach the end of it's useful life and the voltage level to the transmitter drops, this indicator will come on. LOW POWER off (0 V) is good. LOW POWER on (1.8 V) indicates that the battery needs to be replaced.
- FAULT: RF FAULT indicator. 0 V is good - no faults. 1.8 V indicates RF faults. Check antenna connections and make sure that the transmitter is powered.

# Sensitivity (Shunt Calibration)

A power-up calibration sequence is generated to provide the user a means to relate output voltage (the voltage recorded) to engineering units of torque. This sequence also allows for background noise checking. The calibration sequence can also help the user monitor bridge-offset or gain changes which may indicate a problem.

When powered up, the transmitter generates a calibration sequence that lasts approximately 3 seconds. An example of this sequence is shown in Figure 13.

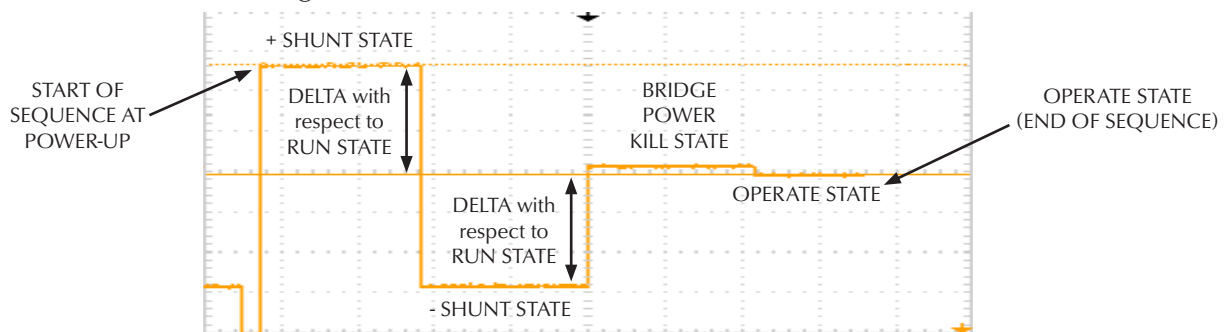

The sequence begins with a shunt calibration resistor applied across the positive excitation (P+) and positive signal (S+). This is referred to as the +SHUNT MODE. This shunting produces an electrical unbalance of the bridge that produces a positive voltage shift as shown. The amount of voltage shift (or delta) is equivalent to a corresponding voltage shift that would result from a physical strain applied to the transducer as determined by the factory calibration of the transducers.

The next part of the sequence directly following the +SHUNT mode is the -SHUNT MODE. As for the +SHUNT mode this likewise electrically offsets the bridge but now in the negative direction due to placement of the shunt resistor across the positive excitation (P+) and negative signal (S-) leads of the transducer bridge.

The next sequence mode is BRIDGE KILL MODE. During this mode the bridge excitation is removed but the signal amplifiers remain active. This provides an opportunity to check for background noise (for example due to EMI). The vehicle should be running (wheels turning) to best evaluate the level of background noise. Any dynamic signal that is present during bridge kill mode is noise.

The end of the sequence is noted by OPERATE MODE. This is the normal “measurement-taking” mode.

## Notes

The calibration sequence may show a negative voltage shift, then a positive shift, if the receiver internal polarity jumper has been changed. A polarity change will not affect the system calibration or channel sensitivity (other than changing the sign of the output).

## System Troubleshooting

The following are guidelines to help in determining the cause of problems you may experience with the telemetry torque measurement system. These guidelines are arranged in categories of failure symptoms. Areas to check for problems are listed for each specific symptom.

1. Receiver Power Indicator Light Does Not Come On
  - a) Insure that the power cord is plugged into a reliable 9-36 Vdc source.
  - b) Check the fuses inside the enclosure and in the wire harness connected to the battery.
2. Fault/Signal strength LED is always ON
  - a) Try a different antenna location or orientation.
  - b) Check the battery voltage level. Replace batteries as required.
3. Calibration sequence generated differs from expected
  - d) Check battery power level to the transmitter. Replace batteries as required.
  - e) Check the transducer bridge zero balance offset. Zero balance of the transducer bridge should be within 5 % of the rated full-scale value. If the bridge balance exceeds 5%, balancing resistors can be installed on the transducer to correct for this offset.

## CBT Mounting

### Required Tools

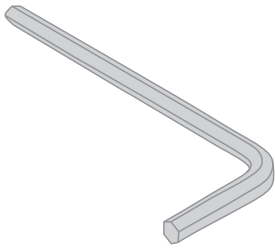

Allen Wrench



Zip Ties or Hose Clamps



Cable Tie Gun

### Full System

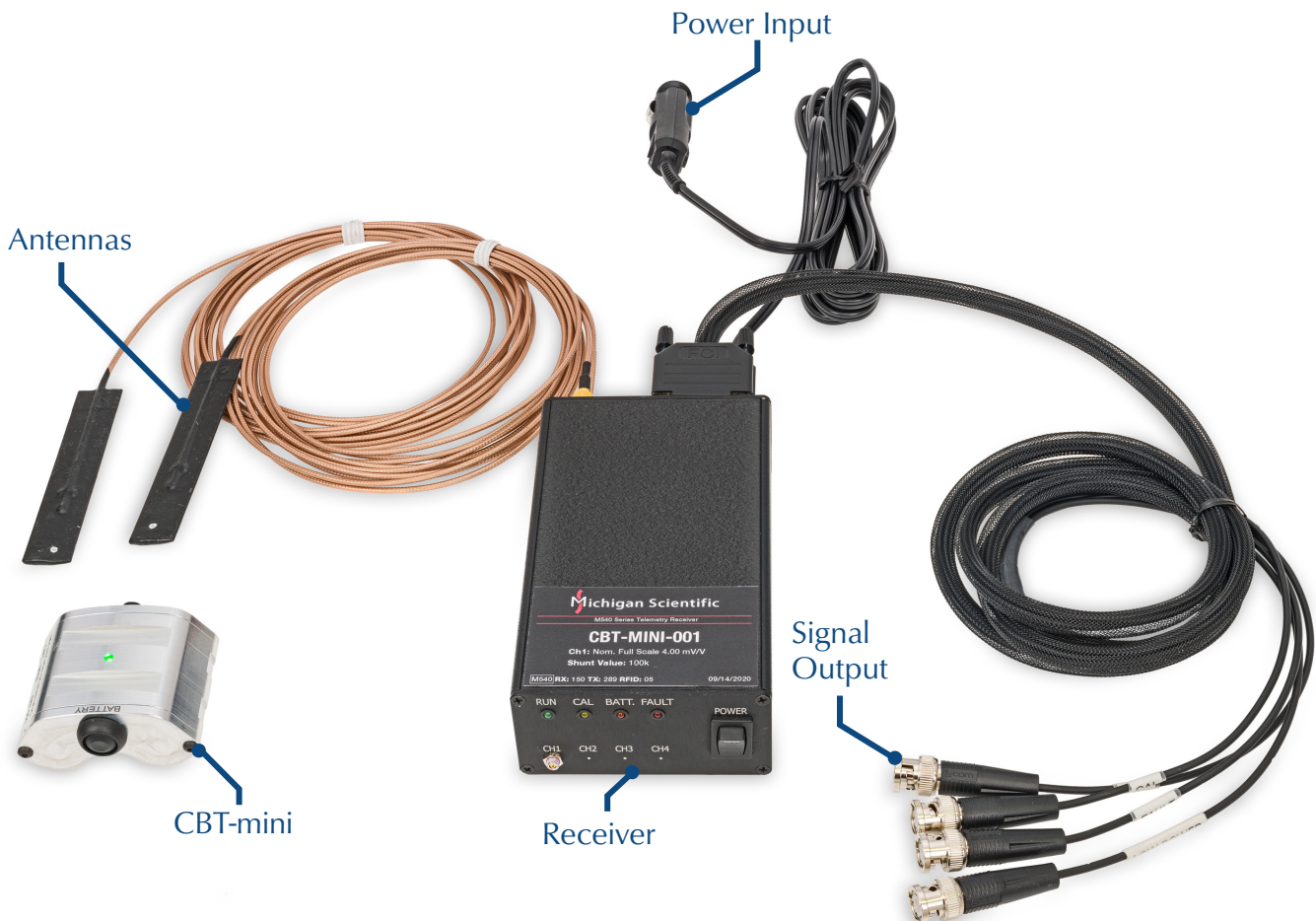

## Mounting Location

1. Ensure the gauge location leaves enough clearance and space to comfortably fit the CBT.
2. Include space to take the lid off and slide the batteries out.
3. Mark desired gauge location

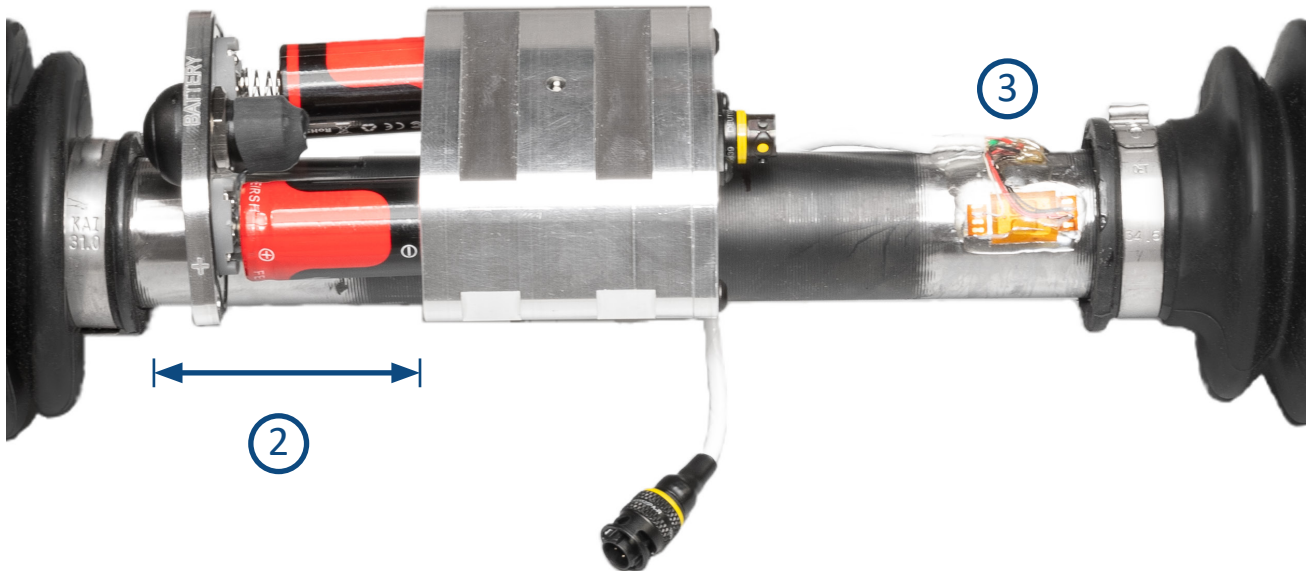
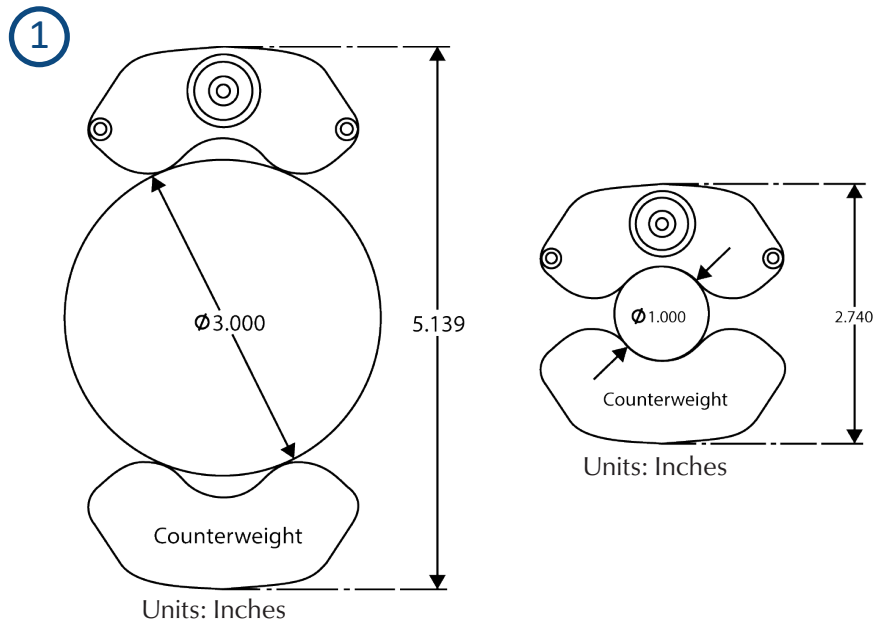

## Mounting

Apply fusion tape to prevent slip during rotation.



Pre-attach zip ties / metal bands.



Connect auto sport connector.

Mount CBT on fusion tape, lid slightly overhanging.



Partially tighten retention band.

Adjust counterweight to be 180 degrees from CBT.



Tighten partially tightened retention band.

Tighten second retention band

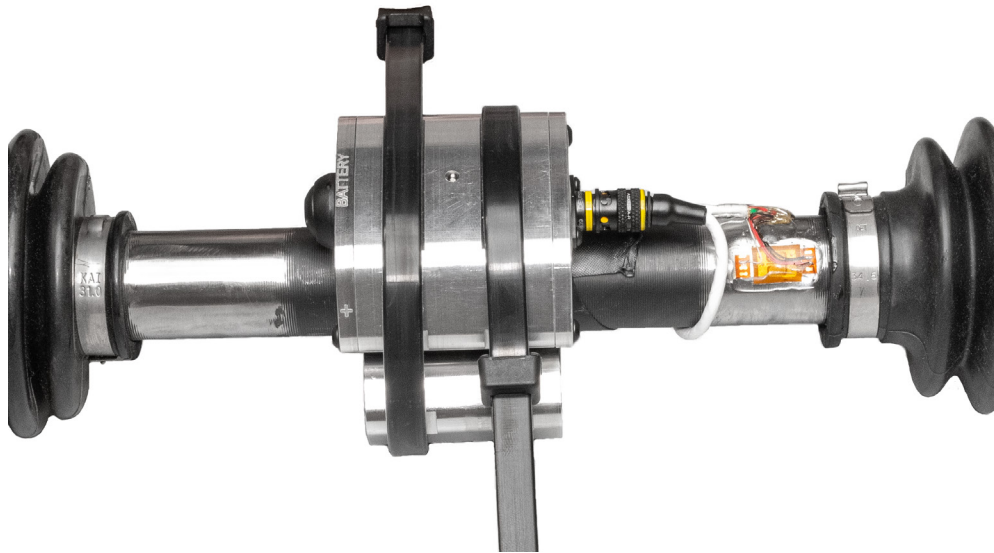

Zip tie tool for zip ties or 30 lb-in for hose clamp



Internal magnets used to remove / guide batteries.

