

\*HOUSING BORE TO SUIT PROBE:  $\phi 20.10$  TO  $\phi 20.15$  (§ 16.7% TO 11.4% SQUEEZE WITH 16x2.4 O-RING). RETAIN PROBE WITH GRUB SCREW.

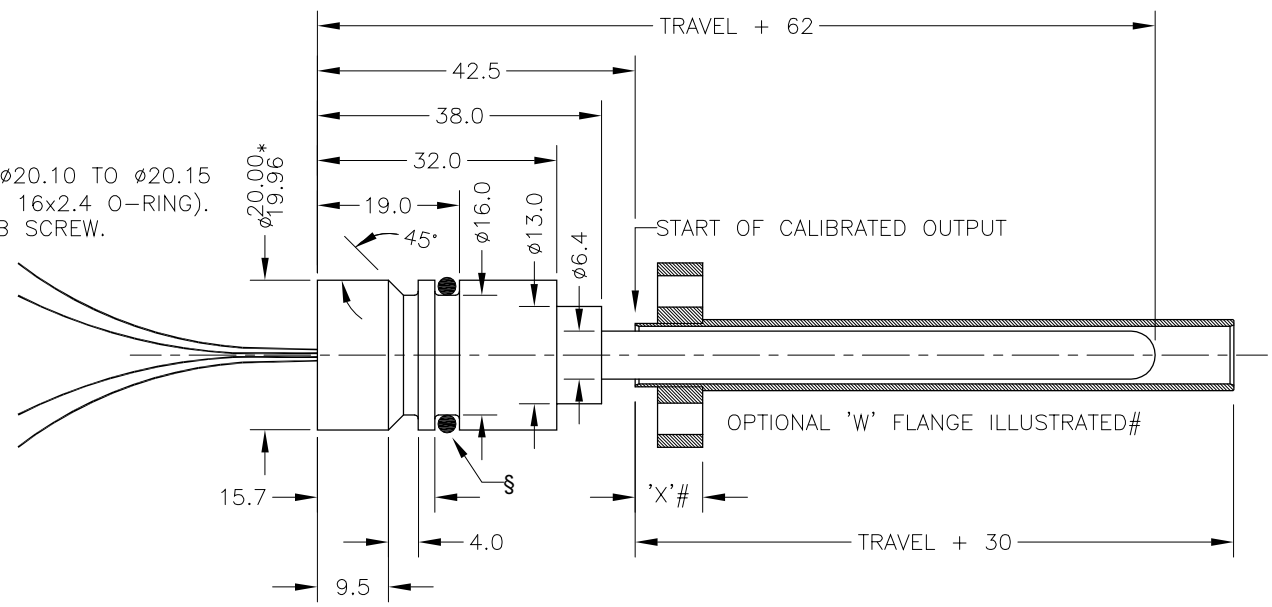

**ELECTRICAL OPTIONS/ SPECIFICATIONS**

OUTPUT	SUPPLY
0.5 TO 4.5V RATIOMETRIC	5V
SUPPLY CURRENT 12mA TYP. 20mA MAX.	

CABLE: 0.2mm<sup>2</sup>, O/A SCREEN, PUR JACKET – SUPPLIED WITH 50cm OR REQUIRED LENGTH IN cm (15000cm MAX).  
 STANDARD 3-CORE: JACKET  $\phi 4$ mm BLACK e.g. L50  
 OPTIONAL 5-CORE: JACKET  $\phi 4.6$ mm BLUE e.g. LQ50

CABLE/CONNECTOR\* CONNECTIONS;

3 CORE	5 CORE	CONNECTOR
RED	RED	:1 +Ve
-	ORG	:1 +SENSE (5-WIRE ONLY)
BLACK	BLACK	:3 0V
-	GRY	:3 -SENSE (5-WIRE ONLY)
WHITE	WHITE	:2 OUTPUT
SCREEN	SCREEN	:4 BODY

\*CONNECTORS; MAXIMUM CONDUCTOR CROSS SECTION 0.75mm<sup>2</sup>  
 RANGE OF DISPLACEMENT FROM 0–5mm TO 0–800mm e.g.76, IN INCREMENTS OF 1mm.

BODY TUBE/PROBE HOUSING MATERIAL: STAINLESS STEEL.  
 35 A/F BASE MATERIAL: STAINLESS STEEL (CODE 'P')  
 FLANGE MATERIAL: STAINLESS STEEL (CODE 'T')

FURTHER OPTIONS:  
 SEE DRAWING TG24-11 FOR #OPTIONAL FLANGE DETAILS AND ORDERING INFORMATION.

TARGET TUBE:  
 STAINLESS STEEL 316  $\phi 9.45$  OPTION 'R'  
 SEE P100-12 FOR DETAILS TYPICAL TARGET TUBE MOUNTING ARRANGEMENTS

NOTE:- READ INSTALLATION SHEET X106-19 FOR FULL INSTRUCTIONS FOR USE.

**ATEX / IECEx APPROVED TO**

**Ex ia IIC T4 Ga (Ta= -40° to +80°C)**  
 Ui 11.4V, li 0.2A, Pi 0.51W

APPROVED FOR USE IN CONJUNCTION WITH A GALVANICALLY ISOLATED BARRIER.

NOTE: APPROVAL ONLY APPLIES AT NORMAL ATMOSPHERIC PRESSURE!

CONNECTIONS BETWEEN PROBE AND ELECTRONICS MODULE: FOUR WIRES; RED, BLACK, GREEN AND YELLOW, LENGTH: 300, CROSS SECTION: 0.25mm<sup>2</sup>, WIRES POTTED IN PROBE HOUSING. INTERCONNECTIONS MUST BE PROTECTED FROM WATER INGRESS AND STRAIN RELIEVED.

G	ADDITIONAL DIMS/VIEWS ADDED.	PDM
H	APPROVAL STANDARDS UPDATED - RAN465.	PDM
J	OPTION 'S' REMOVED - RAN1035.	PDM
K	RANGE WAS 50-600mm RAN1056	RDS
L	TARGET NOTES AMENDED ~ RAN1114	PDM
M	5-CORE OPTION ADDED ~ RAN1102	PDM
N	RANGE NOTE AMENDED ~ RAN1200	PDM



DRAWINGS NOT TO BE CHANGED WITHOUT REFERENCE TO THE CHANGE PROCEDURE. CHANGES TO PARTS USED IN INTRINSICALLY SAFE PRODUCT MUST BE APPROVED BY THE AUTHORISED PERSON. THIS IS AN UNCONTROLLED PRINT AND WILL NOT BE UPDATED.

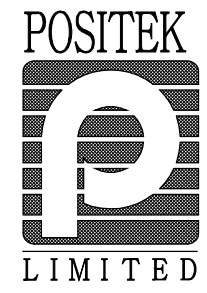

G	05/07/11		CHECKED BY	X	±0.4
H	10/03/14		RDS	X.X	±0.2
J	29/06/15			X.XX	±0.1
					DIMS mm
K	9/11/15	DESCRIPTION			
L	18/10/16	X106 IS INT'NAL MOUNTED			
M	11/04/17	CYLINDER SENSOR WITH			
N	30/08/17	EXTERNAL ELECTRONICS			
SCALE		DRAWING NUMBER		X106-11	REV N
10mm					SHEET 1 OF 1

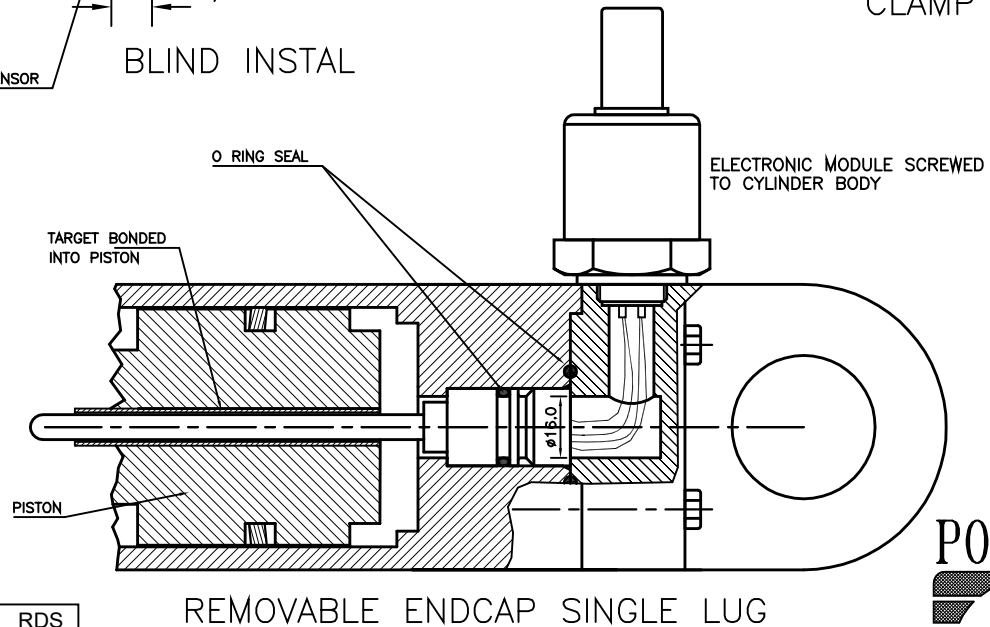
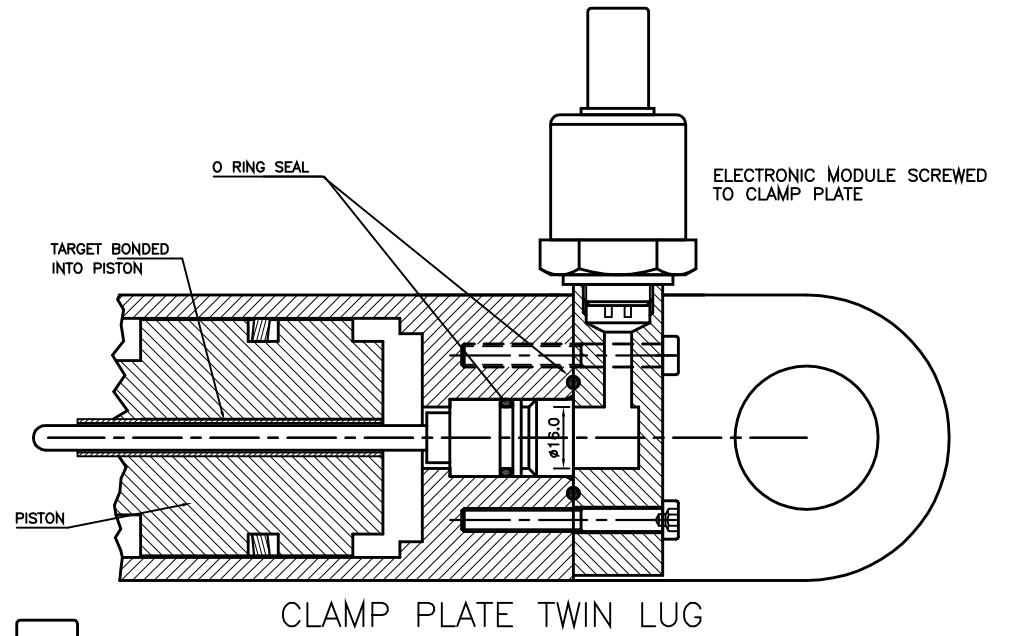
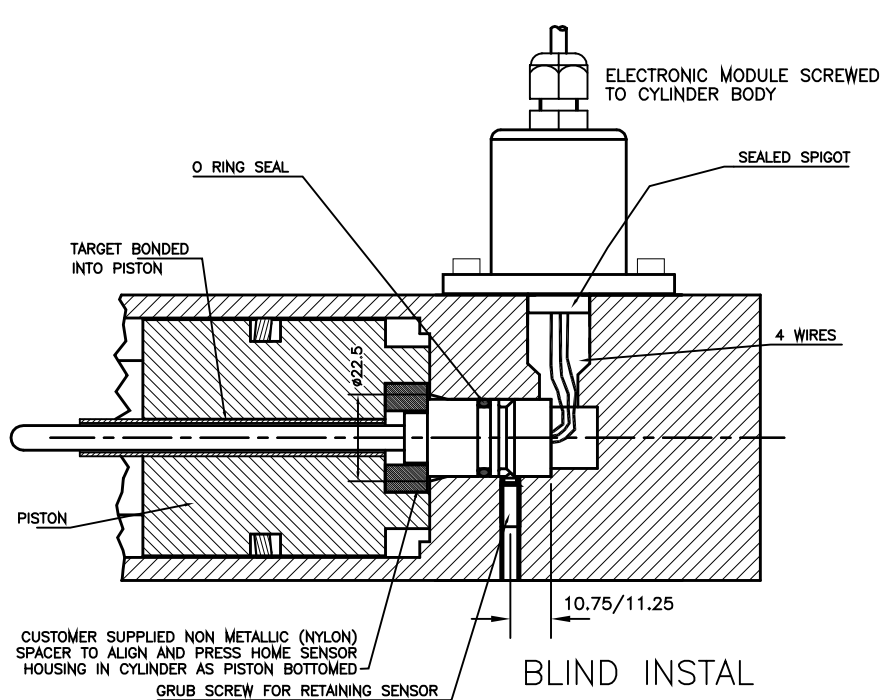

A	FIRST ISSUE	RDS
B	ELECTRONICS HOUSING UPDATED	RDS
C	ENDCAP VERSION ADDED	RDS
D	BLIND INSTAL VIEW AMENDED.	RDS

DRAWINGS NOT TO BE CHANGED WITHOUT REFERENCE TO THE CHANGE PROCEDURE.  
 CHANGES TO PARTS USED IN INTRINSICALLY SAFE PRODUCT MUST BE APPROVED  
 BY THE AUTHORISED PERSON  
 THIS IS AN UNCONTROLLED PRINT AND WILL NOT BE UPDATED.

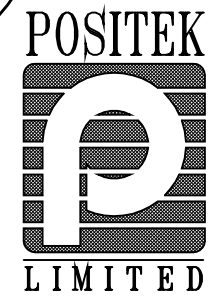

A	27/06/97		CHECKED BY	X	±0.4
B	05/05/02		RDS	X.X	±0.2
C	15/12/15			X.XX	±0.1
D	16/12/15				DIMS mm
DESCRIPTION		GENERAL ARRANGEMENT INTERNALLY MOUNTED CYLINDER SENSOR			
SCALE	NTS	DRAWING NUMBER		P106-13	REV <input type="checkbox"/> D
		SHEET		1	OF 1

TARGET TUBE OPTION NOTES:-

- SPECIFY TUBE MATERIAL; CODE:-  
'R' STAINLESS STEEL 316  $\phi$ 9.45.  
'S' ALUMINIUM 6063  $\phi$ 3/8" (9.2-9.8). NOTE! ONLY AVAILABLE WITH P100 OR P106 VERSIONS.
- SPECIFY FLANGE TYPE; CODE: 'U', 'Vx', 'Wx' OR 'Xx' ~ SEE DETAILS BELOW.
- SPECIFY DIMENSION 'x' (mm), NOT APPLICABLE CODE 'U' PLAIN TUBE.

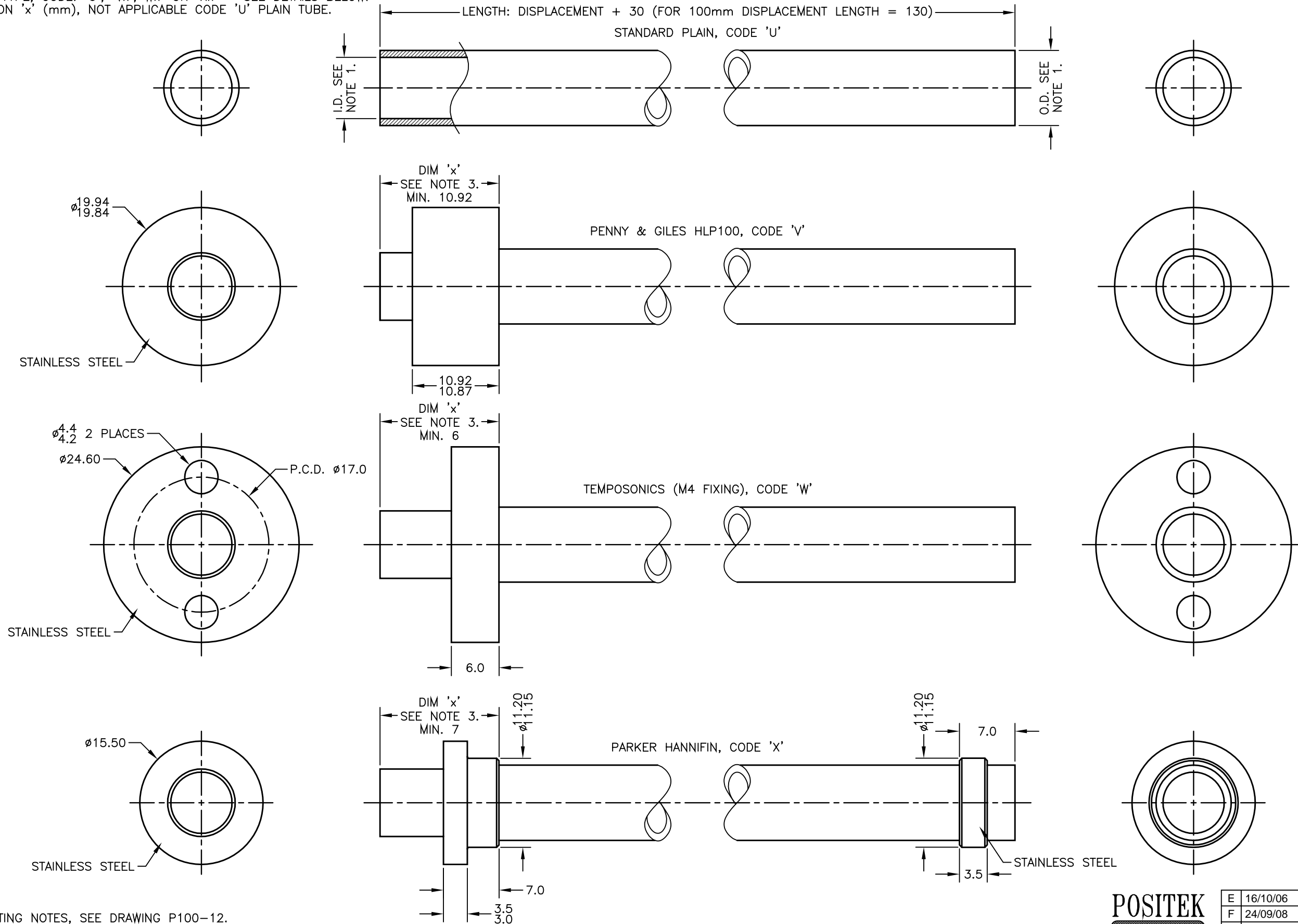

TARGET TUBE MOUNTING NOTES, SEE DRAWING P100-12.

E	MATERIAL OPTION REMOVED.	PDM
F	MAT'L OPTION REINSTATED RAN221.	PDM
G	X DIM FOR PH FLANGE SHOWN RAN225	RDS
H	9.45 WAS 9.5 RAN396	RDS
J	REDRAWN, PH FLANGE ROTATED RAN507.	PDM
K	NOTE 1 AMENDED ~ RAN1114.	PDM
L	'x' WAS 'n' ~ RAN1309	PDM

DRAWINGS NOT TO BE CHANGED WITHOUT REFERENCE TO THE CHANGE PROCEDURE.  
CHANGES TO PARTS USED IN INTRINSICALLY SAFE PRODUCT MUST BE APPROVED  
BY THE AUTHORISED PERSON  
THIS IS AN UNCONTROLLED PRINT AND WILL NOT BE UPDATED.



E	16/10/06	CHECKED BY X	±0.4
F	24/09/08		
G	13/11/08	RDM	X.XX ±0.1
H	11/12/12		DIMS mm
J	23/07/14	DESCRIPTION	
K	30/11/16	TARGET TUBE AND FLANGE	
L	08/11/22	OPTIONS (LIPS 100/106)	
SCALE		DRAWING NUMBER	
5mm		TG24-11	
↔		REV L	
		SHEET 1 OF 1	