

Brake Pedal Force Transducer

Model BPFT

- 500 lb capacity
- High accuracy for on and off center loading
- Fits standard brake pedals
- Fits parking brake pedals
- Rugged aluminum construction



Description

The Michigan Scientific *Brake Pedal Force Transducer (BPFT)* is a precision strain gage load cell. This transducer was designed to accommodate the brake pedals of most cars, as well as parking brake pedals. It features high accuracy for both on-center and off-center loading.

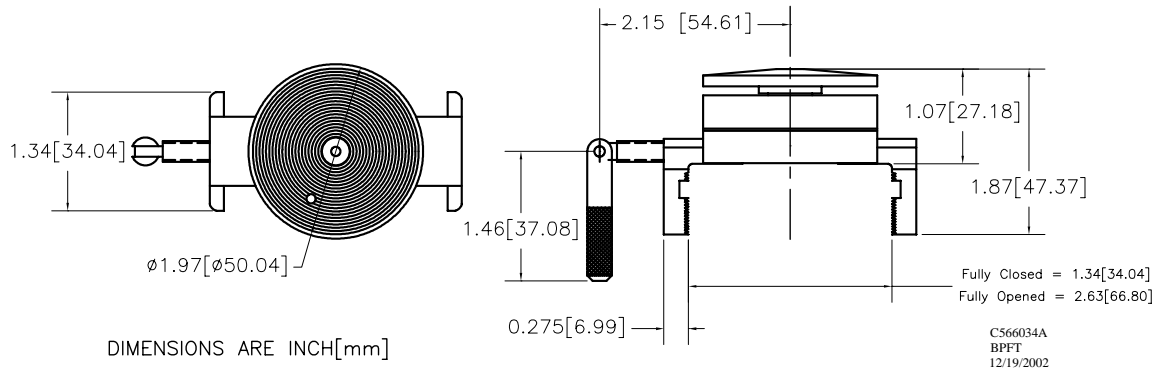

Specifications

Maximum Load Capacity	500 lbs (230 kg)
Full Scale Load	500 lbs (230 kg)
Weight	4.2 oz (119 g)
Fatigue Rating for Single Axis (full load)	>10 ⁶ cycles
Full Scale Output	1.5 mV/V, nominal, all channels
Sensor	1 four-arm strain gage bridges
Nonlinearity	2.0% of full scale output
Hysteresis	1.0% of full scale output
Repeatability	1.0% of full scale output
Zero Balance	Within ± 10.0% of rated output at zero load
Bridge Resistance	700Ω nominal Fx & Fy, 1400Ω nominal Fz
Temperature Effect on Zero	0.008% reading/ °F (0.0015% reading/ °C)
Temperature Range, Compensated*	75°F to 200°F (24°C to 93°C)
Temperature Range, Useable	-40°F to 300°F (-40°C to 149°C)
Excitation Voltage, Maximum	10V DC or AC rms
Insulation Resistance, Bridge/Case	Exceeds 5000 MΩ
Standard Cable Length (bare leads)	10 ft

* Contact factory for other compensated ranges

8500 Ance Road
Charlevoix, MI 49720
Tel: 231-547-5511
Fax: 231-547-7070
Rev: 8/27/03

MICHIGAN SCIENTIFIC
<http://www.michsci.com>
Email: mscinfo@michsci.com
corporation

321 East Huron Street
Milford, MI 48381
Tel: 248-685-3939
Fax: 248-684-5406

This page is intentionally blank.

8500 Ance Road
Charlevoix, MI 49720
Tel: 231-547-5511
Fax: 231-547-7070
Rev: 8/27/03

MICHIGAN SCIENTIFIC

corporation

<http://www.michsci.com>
Email: mscinfo@michsci.com

321 East Huron Street
Milford, MI 48381
Tel: 248-685-3939
Fax: 248-684-5406

Low Profile Brake Pedal Force Transducer

Model BPFT2

- 500 lb capacity
- High accuracy for on and off center loading
- Fits standard brake pedals
- Rugged construction



Description

Michigan Scientific's *Low Profile Brake Pedal Force Transducer (BPFT2)* is a precision strain gage load cell. It attaches directly onto a vehicle's brake pedal quickly and securely by removing the rubber pad and tightening the single retaining bolt. Designed to accommodate the brake pedal of most cars, the low profile and size closely duplicates the shape and feel of a production brake pedal, while adding minimal height and weight. It features high accuracy for both on-center and off-center loading.

Specifications

Maximum Load Capacity	500 lbs
Full Scale Load	500 lbs
Full Scale Output	2.75 mV/V, nominal
Sensor	1 four-arm strain gage bridge
Nonlinearity	2.0% of full scale output
Hysteresis	1.0% of full scale output
Repeatability	1.0% of full scale output
Zero Balance	Within $\pm 10.0\%$ of rated output at zero load
Bridge Resistance	350 Ω
Temperature Effect on Zero	0.008% reading/ $^{\circ}\text{F}$ (0.0015% reading/ $^{\circ}\text{C}$)
Temperature Range, Useable	-40 $^{\circ}\text{F}$ to 200 $^{\circ}\text{F}$ (-40 $^{\circ}\text{C}$ to 95 $^{\circ}\text{C}$)
Excitation Voltage, Maximum	10V DC or AC rms
Insulation Resistance, Bridge/Case	Exceeds 5000 M Ω
Standard Cable Length (bare leads)	10 ft (3 M)
Weight	12.4 oz (350 g)

Low Profile Brake Pedal Force Transducer

BPFT2 Configuration

