

LCI 360 Inclinometer

**BEST OF
CLASS**



The Jewell LCI-360 is a biaxial unit that meets the needs of high accuracy applications with low shock and vibration. The LCI employs a torsion flexure suspension that offers superior repeatability and low hysteresis at low frequencies.

LCI 360 Specifications

Performance

Input Range ¹ , °:	±14.5	±30.0	±90.0
Full Range Output (FRO), ±0.50% ² VDC:	±5.0	±5.0	±5.0
Nonlinearity, % FRO ³ , maximum:	0.02	0.02	0.05
Scale Factor, volts/g, nominal:	20.0	10.0	5.0
Scale Factor Temp Sensitivity, PPM/°C:	100.0	100.0	100.0
Natural Frequency, Hz, nominal ⁴ :	5.0	5.0	5.0
Bandwidth (-3dB) Hz, nominal:	5.0	5.0	5.0
Output Axis Misalignment, °, maximum:	0.50	0.50	0.50
Pendulous Axis Misalignment, °, maximum:	1.00	1.00	1.00
Output at 0° Tilt, volts, maximum:	0.050	0.050	0.025
0° Output Temp Sensitivity, volts/°C, maximum:	0.0005	0.0003	0.0001
Resolution and Threshold:	1μradian		

Electrical

Input Voltage, VDC, ⁵ :	±12 to ±18		
Input Current, mA, nominal:	30		
Output Impedance, ohms, nominal:	100		
Noise, Vrms, maximum:	0.0005	0.0003	0.0001

Environmental

Operating Temp Range:	-55° C to +85° C		
Survival Temp Range:	-60° C to +90° C		
Shock:	3 foot drop		
Seal:	MIL-STD 202, Method 112		
Weight:	8.0 oz.		

¹ Other ranges are also available. Please contact us for special request.

² Full Range is defined "from negative full input angle to positive full input angle, independent of misalignment.

³ Nonlinearity is specified as deviation of output referenced to theoretical sine function value.

⁴ Output Phase angle = -90°.

⁵ Unit Power connections can be easily adapted for operations from single-ended, floating power supplies of 24 to 36 Volts DC.

Applications

- ▶ Machine Tool Leveling
- ▶ Laboratory Testing
- ▶ Geophysical Measurement
- ▶ Antenna Orientation
- ▶ Dam Monitoring



LCI 360 Inclinometer

Dimensional Drawing for the LCI Inclinometer (inch/mm)

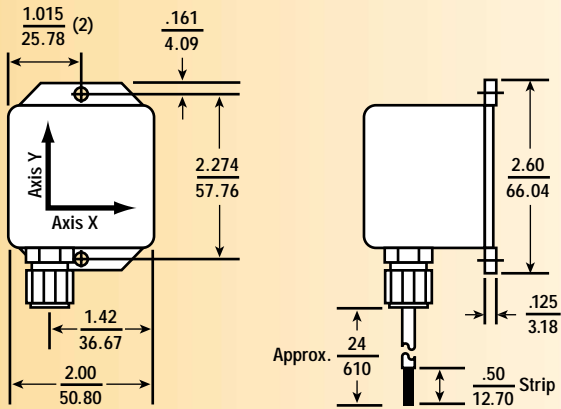

Wire Function

Black - Power/Signal Com.
 White - -12 to -18 Vdc
 Red - +12 to +18 Vdc
 Green - Output, Axis X
 Orange - Case Com
 Blue - Output, Axis Y

Block Diagram for the LCI Inclinometer

