



LCI Series Flexure Suspension Servo Inclinometer

**BEST OF
CLASS**



The Jewell LCI Series Inclinometer is a $\pm 14.5^\circ$ to $\pm 90^\circ$ device designed for low frequency tilt sensing applications. LCI units are characterized by excellent turn on repeatability and very low hysteresis.

LCI Series Flexure Suspension Servo Inclinometer Specifications

Performance

Input Range, ° (Note 1)	± 14.5	± 30	± 90
Full Range Output (FRO), VDC $\pm 0.5\%$	± 5.0	± 5.0	± 5.0
Nonlinearity % FRO max (Note 2)	0.02	0.02	0.05
Scale Factor, volts/g nominal	20.0	10.0	5.0
Scale Factor Temp Sens, PPM/°C max	100	100	100
Natural Frequency, Hz nominal (Note 3)	5	5	5
Bandwidth (-3dB), Hz nominal	5	5	5
Input Axis Misalignment, ° max	0.50	1.00	1.00
Bias, volts max	0.050	0.050	0.025
Zero Tilt Temp Sens, volts/°C max	0.0005	0.0003	0.0003
Resolution and Threshold, μ rad max	1	1	1

Electrical

Input Voltage, VDC	± 12 to ± 18
Input Current, mA nominal	± 25
Output Impedance, ohms nominal	100 ohms
Noise, Vrms max	0.0005

Environmental

Operating Temp Range	-55 to +85°C
Survival Temp Range	-60 to +90°C
Shock	3-foot drop
Seal	Epoxy

NOTE 1: Full Range is defined as “from negative full input angle to positive full input angle.”

The Inclinometer output is proportional to the sine of the tilt angle.

NOTE 2: Referenced to theoretical sine value independent of misalignment.

NOTE 3: Output phase angle = -90° .

Applications

- Robotics Orientation
- Antenna Leveling
- Laboratory Testing



LCI Series Accelerometer

Block Diagram

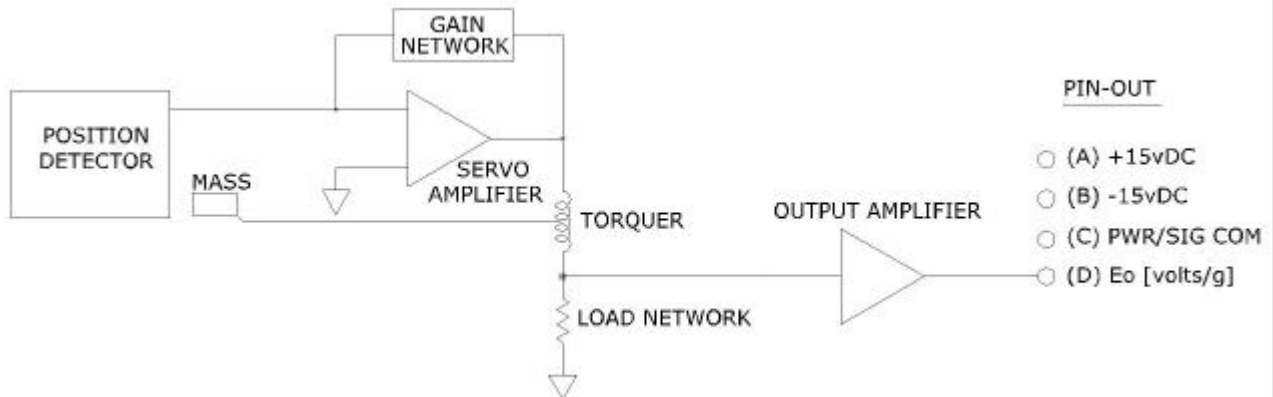

Outline Diagram

