

DUAL AXIS INCLINOMETER $\pm 10^\circ$.. $\pm 45^\circ$

DAS-XX-MC-V (analog voltage output)

DAS-XX-MC-I (4..... 20 mA output)

PROFILE

The inclinometer working principle is based on a micro machined silicon capacitive transducer (developed with MEMS technology). Output signal from the sensing element, coming as a duty-cicle modulated waveform with carrying frequency of 100 Hz, is acquired by a microprocessing unit. The microprocessor provides continuous sampling of X and Y axes every 25 ms and gives as an output the angular information after performing Arcsin (X,Y) calculation. The inclinometer have a compact design , low vibration sensitivity , low price and find application in a variety of industrial and automotive application .

Main Characteristics

- Measuring range $\pm 10^\circ$, $\pm 30^\circ$, $\pm 45^\circ$
- Voltage supply 7 to 30 VDC;
- Operating temperature range -20°C to 70°C
- MEMS sensors high stability
- Low power consumption
- High resistance to mechanical shocks;
- No trimmers used for settings;
- Extremely low cross sensitivity;
- Alluminium housing IP67

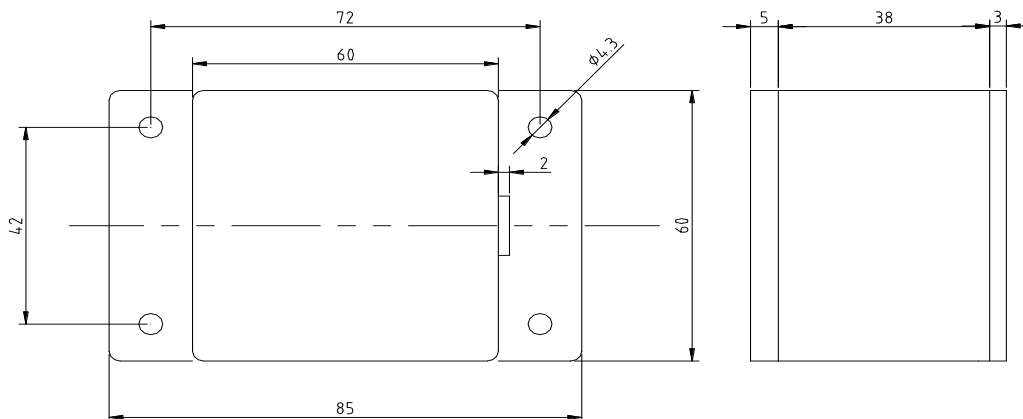
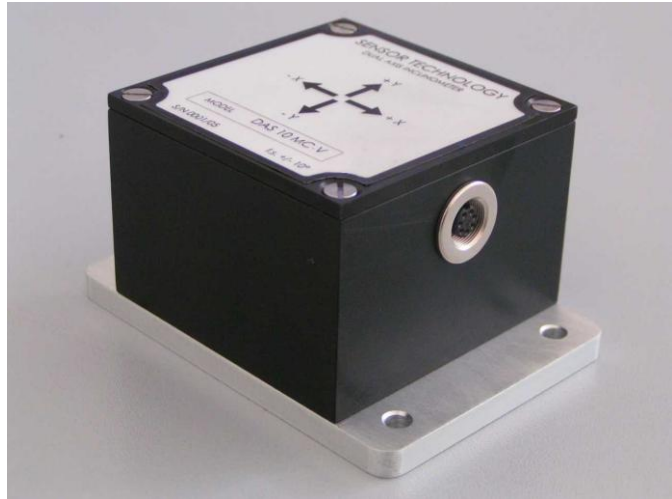

Technical characteristics

DAS-XX-MC-V (analog voltage output)		
Meas range	°	+/- 10 , +/- 30 , +/- 45
Input Voltage	Volt	7 to 30 volt
Y-X out zero	Volt	2.5 V +/- 50mV
Sensitivity	V	0,5 to 4,5 Volt 4-20 mA
Linearity	% FS	< 1 max %
Resolution	°	0,005 per 10 ° 0,015 per 30 ° 0,02 per 45
Insulating resistance	Mohm	> 100 Mohm @500Vdc
Compansated temperature range	° C	0°C to 60°C -20 °C + 70 ° C
Stocking temeprature	° C	-40+ 80 °C
Frequency response	s	0.3 (factory calibrated)
Zero drift (T from 0° to 60°)	°	< 0.10
Temperature Sensivity drift (T from 0° to 60°)	°	< 0.1
Cross axis error	% FS	<1 % at max tilt
Shock resistance	According MIL- STD 202 E 213 B	1000 g
Vibration resistance	According MIL STD 202E 204 C	20 g (10 to 2000 Hertz)
Dimensions	mm	Vedi Disegno
Weight	G	500

DAS-XX-MC-V

DAS-XX-MC-I

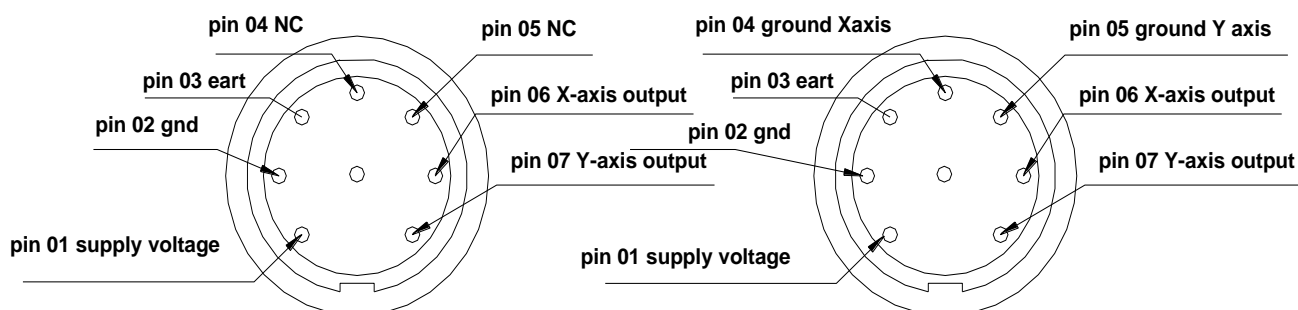

Connettore Binder serie 712

SN 09-0428-00-08