

Electronic Protractor System

The Anglestar® Protractor System (APS) is a ready to use, stand alone system for angle measurements. The system incorporates the AccuStar® Electronic Clinometer, a digital display, and a four foot cable. (Cable lengths up to 200 feet are available. Consult factory for details.) This system works on a 9 volt battery and needs no external power.

The display can be mounted up to 200 feet from the sensor. There are three systems to choose from, ± 20 degrees with a 0.01 degree resolution, $\pm 45^\circ$, or a $+90^\circ$ with 0.1 degree resolution.

Features

- ❑ **Three-part system – sensor, LCD display and cable**
- ❑ **Remote sensing – 200 feet for display**
- ❑ **Ranges: $\pm 20^\circ$, $\pm 45^\circ$ or $+90^\circ$**

Applications

- ❑ **Platform leveling**
- ❑ **Antenna positioning**
- ❑ **Mining equipment**
- ❑ **Machine tooling**

Performance Specifications

Standard (P/N 02160001-000)

Linear Range $\pm 45^\circ$
Threshold & Resolution 0.1°

High Resolution (P/N 02160003-000)

Linear Range $\pm 19.99^\circ$
Threshold & Resolution 0.01°

90 Degree (P/N 02160005-000)

Linear Range 0° to 90°
Threshold & Resolution 0.1°

Linearity*

Null to 10° 0.1°
 10° to 45° $\pm 1\%$ of angle

Null Repeatability $\pm 0.1^\circ$
Cross Axis Error $< 1\%$ up to 45°
Sensor Time Constant 0.3 second
Sensor Frequency Response 0.5 Hz

Electrical Specifications

Voltage Supply 9 volt battery
Battery Life (approx.) 1000 hours
Temperature Range -18° to 55°C
Interconnect Cable

Four Conductor, AWG 26, PVC Jacket
Standard Length 4 feet (≈ 1.2 meters)
Maximum Length 200 feet (≈ 61.5 meters)

*Linearity specification applies to standard and high resolution systems only.



Dimensions in (mm)

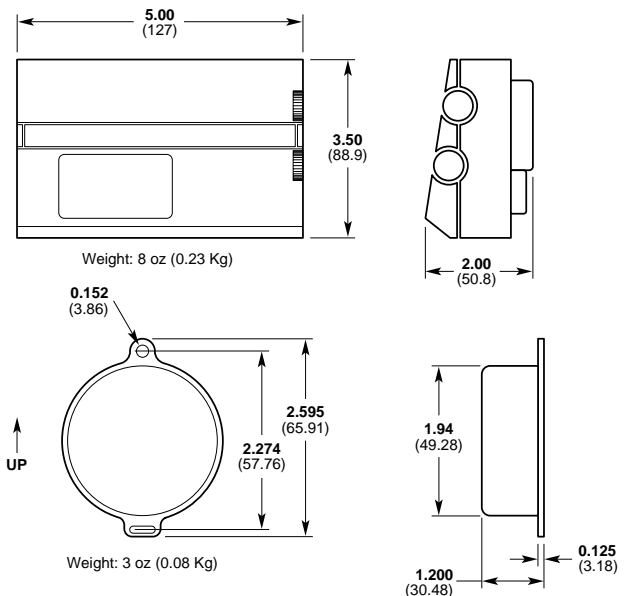

How to Order

Model Number	Range
02160001-000	$\pm 45^\circ$
02160003-000	$\pm 20^\circ$
02160005-000	0° to 90°