

AccuStar[®] Electronic Clinometer



Single Axis $\pm 60^\circ$ Range

The AccuStar[®] Electronic Clinometer is an extremely accurate angle measurement device. This compact and rugged sensor is ideal where space is critical and environmental conditions are serious design concerns.

The heart of the system is a patented, capacitance-based sensor with no moving parts. When rotated about its sensitive axis, this unique sensor provides an exceedingly linear variation in capacitance, which is electronically converted into angular data. The sensor and low-power CMOS electronics are encased in a rugged plastic housing ready to install as a system component or as a stand-alone device.

Designed for easy integration, with a choice of analog, ratiometric, digital or serial models, the clinometer produces an output signal corresponding to direction and magnitude of angular displacement.

Features

- CE certified*
- Just 2" in diameter*
- Rugged plastic housing*
- Extremely accurate*
- Weighs only 2 oz.*

Applications

- Wheel alignment*
- Construction equipment*
- Antenna positioning*
- Robotics*



Performance Specifications

Total Range	$\pm 60^\circ$
Linear Range	$\pm 45^\circ$
Threshold	0.001 $^\circ$
Linearity	
Null to 10 $^\circ$	$\pm 0.1^\circ$
10 to 45 $^\circ$	$\pm 1\%$
45 to 60 $^\circ$	Monotonic
Null Repeatability	0.05 $^\circ$
Cross Axis Error	<1% up to 45 $^\circ$
Time Constant	0.3 sec
Freq. Response (-3db)	0.5 Hz
RF Susceptibility	< $\pm 2^\circ$

Environmental Specifications

Temperature Range	
Operating	-30 $^\circ$ to 65 $^\circ$ C
Storage	-55 $^\circ$ to 65 $^\circ$ C
Temperature Coefficient	
Null	0.008 $^\circ$ / $^\circ$ C
Scale Factor	0.1%/ $^\circ$ C
EMC	
Emissions	EN55022 (CISPR 22) Limit B
Radiated Immunity	IEC 801-3 Level 3 10V/m
Burst Transients	IEC 801-4 Level 3 (2 kV)
ElectroStatic Discharge	IEC 801-2 Level 2 (8 kV air, 6 kV contact)
Conducted RF	MIL-STD 461D, CS114, Curve 2
Cable Length	18" standard length with flying lead terminator



+33 (0)1 46 91 93 32

Capteurs et Systèmes de mesure

59, rue Émile Deschanel - 92400 COURBEVOIE - France - Fax : 33 (0)1 46 91 93 39 - contact@pm-instrumentation.com



AccuStar®
 Range: $\pm 60^\circ$
 Resolution: 0.001°
 Choice of Outputs

Design Concept

The unique design is based on a common capacitor plate sandwiched between sensor housing halves. The plate has been etched to form two variable capacitors. The assembled sensor is half filled with a dielectric liquid and inert gas. Rotation of the sensor produces a linear change in capacitance resulting in a corresponding output signal.

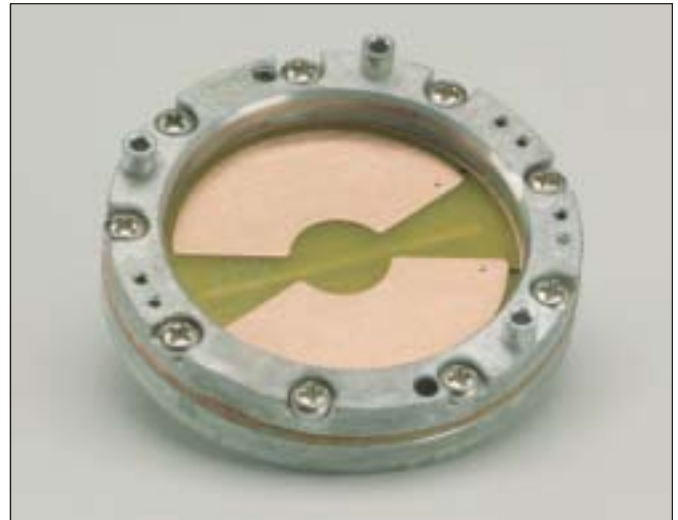

How to Order

Model Number	Description
Ratiometric	
02110002-000	Vertical Flange
02110102-000	Horizontal Flange
Analog	
02111002-000	Vertical Flange
02111102-000	Horizontal Flange
Digital	
02112002-000	Vertical Flange
02112102-000	Horizontal Flange
Serial	
02113002-000	Vertical Flange
02113102-000	Horizontal Flange

Dimensions in (mm)

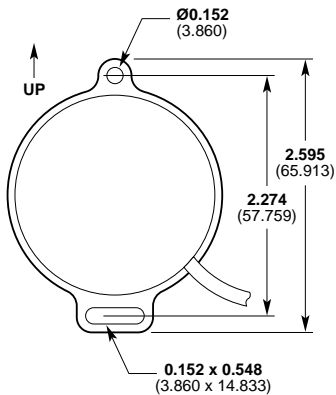

Vertical Flange Mount

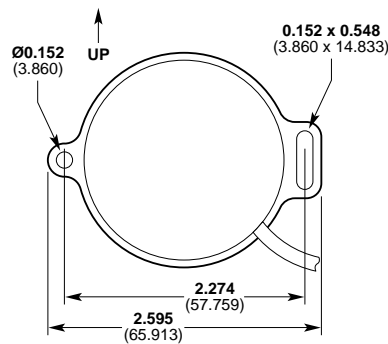

Horizontal Flange Mount

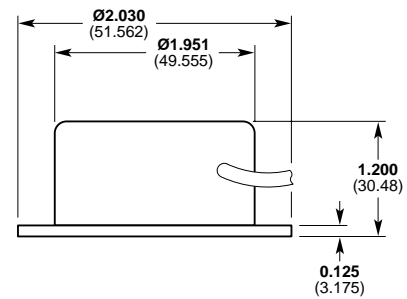

+33 (0)1 46 91 93 32 **Capteurs et Systèmes de mesure**

59, rue Émile Deschanel - 92400 COURBEVOIE - France - Fax : 33 (0)1 46 91 93 39 - contact@pm-instrumentation.com



AccuStar[®] Electronic Clinometer

Ratiometric Output

Features

- ❑ **Low power consumption**
- ❑ **3 wire operation**

The Ratiometric clinometer is a signal conditioned sensor that has been designed to operate like a potentiometer. This is a three wire device: power; power ground; and signal. The signal is referenced to power ground. A regulated power supply is required since the output is supply dependent. The midscale output, zero degrees, is 1/2 the supply voltage while the scale factor is also supply dependent. With its low power consumption, 0.5 mA, this device is ideal for battery supplied applications. The Ratiometric clinometer was designed with EMI and ESD suppression circuitry on every line.

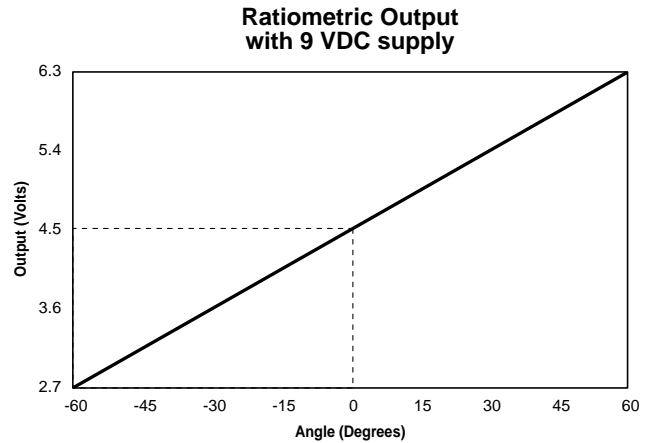

Ratiometric I/O Block Diagram

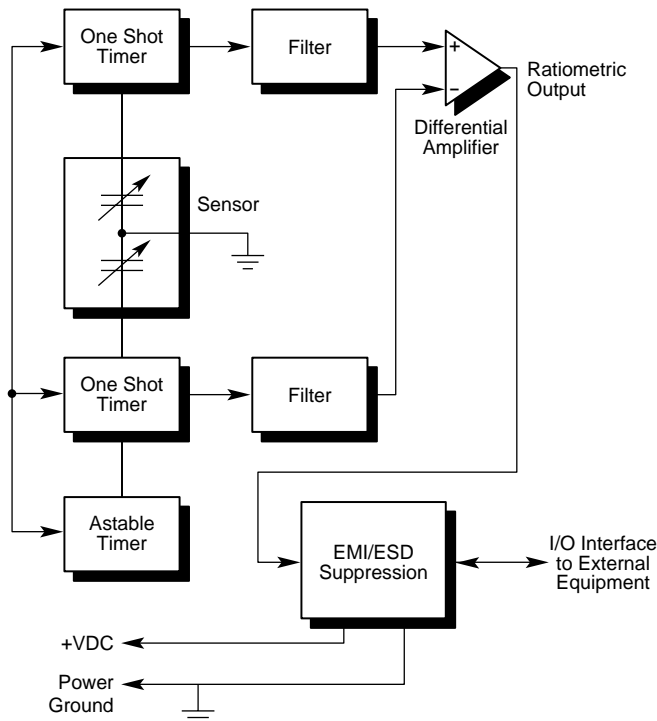

Ratiometric Electrical Specifications

Voltage

Voltage Supply

Nominal +9 VDC

Range (regulated) +5 to +15 VDC

Current 0.5mA

Scale Factor

Nominal (@9VDC) 30mV/degree ±10%

Load Resistance (min.) 10 kOhms

Level Output (0°) 1/2V_{cc}

Electrical Connections

Wire	Source
Black	Power ground
Red	Reg. +5 to +15 VDC
Yellow	Signal output (reference to power ground)

Analog Output

Features

- ❑ **Internally regulated**
- ❑ **Bipolar input/output**

The Analog clinometer is a signal conditioned sensor which has been designed for dc voltage, bipolar operation. The clinometer requires a bipolar supply of ± 8 to ± 15 VDC and delivers an output of ± 3.6 VDC. This device is internally regulated for various applications. The output scale is fixed at a nominal 60mV per degree not dependent on the supply voltage. The Analog clinometer has full EMI and ESD suppression circuitry on every line.

Analog I/O Block Diagram

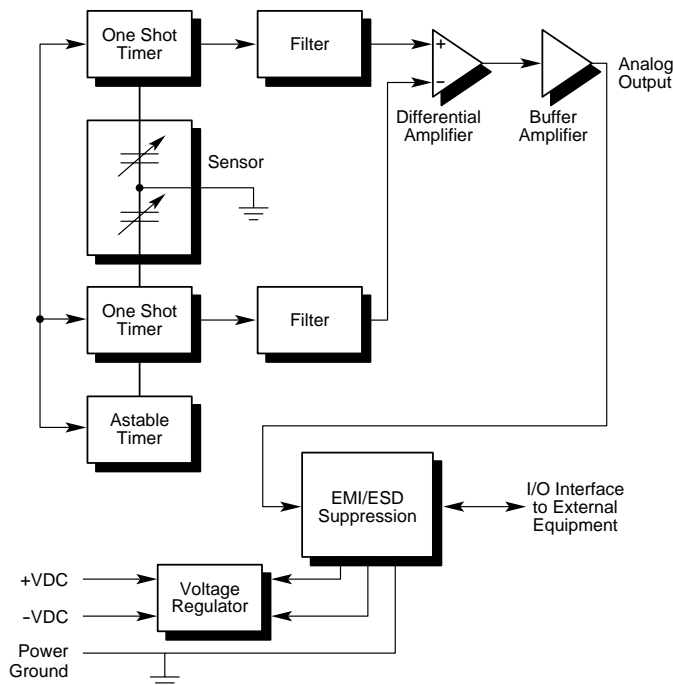

Analog Output

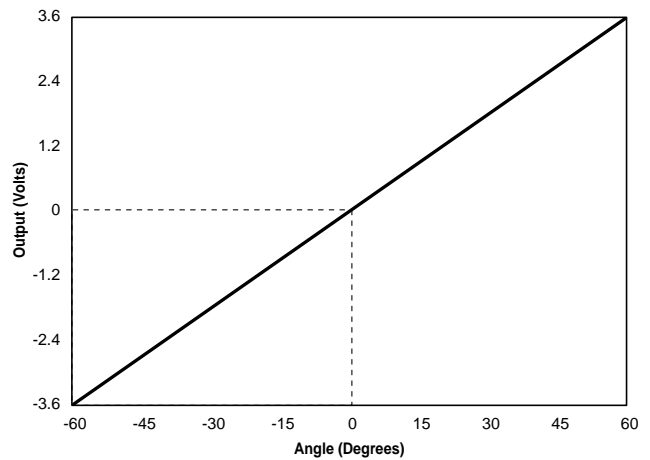

Analog Electrical Specifications

Voltage

Voltage Supply

- Nominal** ± 12 VDC
- Range (regulated)** ± 8 to ± 15 VDC
- Current** 5 mA/supply
- Scale Factor** 60 mV/degree $\pm 10\%$
- Load Resistance (min.)** 10 kOhms
- Level Output (0°)** 0 VDC

Electrical Connections

Wire	Source
Black	Power ground
Red	+8 to +15 VDC
Gray	-8 to -15 VDC
Blue	Signal output (reference to power ground)