

Model 1100 Ultra Precision Load Cell (U.S. & Metric)

Why the Interface model 1100 Ultra Precision Load Cell is the best in class:

- Proprietary Interface temperature compensated strain gages
- Performance to .02%
- High output – to 4 mV/V
- Eccentric load compensated
- Low deflection
- .0008%/°F (.0015%/°C) temp. effect on output
- Shunt calibration
- High precision base included
- Barometric compensation
- Tension and compression

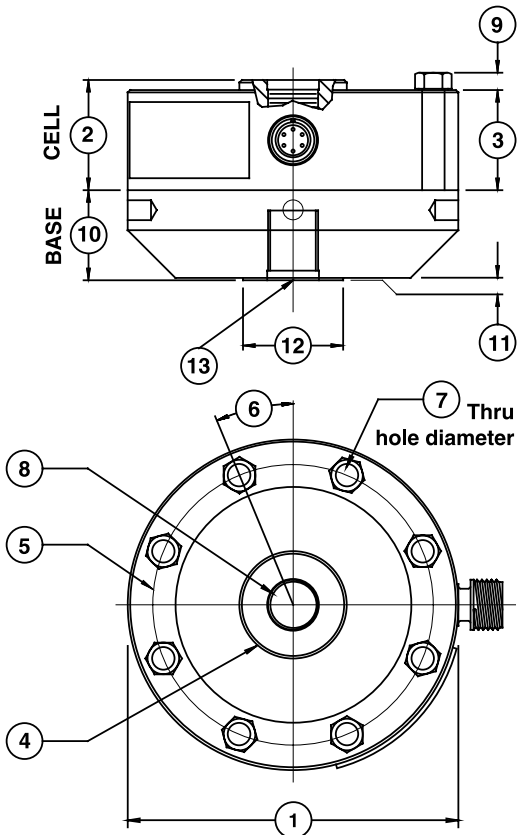

DIMENSIONS

See Drawing	MODEL							
	1110		1120		1132		1140	
	CAPACITY							
	U.S. (lbf)	Metric (kN)	U.S. (lbf)	Metric (kN)	U.S. (lbf)	Metric (kN)	U.S. (lbf)	Metric (kN)
	300, 500, 1K, 2K, 3K, 5K, 10K	1.5, 2.5, 5, 10, 25, 50	25K, 50K	100, 250	100K	450	200K	900
	inch	mm	inch	mm	inch	mm	inch	mm
①	4.13	104.8	6.06	153.9	8.00	203.2	11.0	279.0
②	1.38	34.9	1.75	44.5	2.50	63.5	3.50	88.9
③	1.25	31.7	1.63	41.4	2.25	57.2	3.00	76.2
④	1.34	34.0	2.65	67.3	3.76	95.2	4.81	122.2
⑤	3.50	88.9	5.13	130.3	6.50	165.1	9.00	228.6
⑥	22.5°	22.5°	15.0°	15.0°	11.25°	11.25°	11.25°	11.25°
⑦	0.28	7.10	0.41	10.4	0.53	13.5	0.65	16.5
⑧	5/8-18 UNF-3B	M-16 X 2-4H	1 1/4-12 UNF-3B	M33 X 2-4H	1 3/4-12 UNF-3B	M42 X 2-4H	2 3/4-8 UNF-3B	M72 X 2-4H
	1.12 in deep	28.4 mm deep	1.40 in deep	35.6 mm deep	2.15 in deep	54.6 mm deep	3.25 in deep	82.6 mm deep
⑨	0.20	5.10	0.30	7.60	0.40	10.2	0.50	12.7
⑩	1.13	28.6	1.75	44.5	2.00	50.8	3.00	76.2
⑪	0.03	0.80	0.03	0.80	0.03	0.80	0.03	0.80
⑫	1.25	31.8	2.25	57.2	3.00	76.2	4.50	114.3
⑬	5/8-18 UNF-3B	M-16 X 2-4H	1 1/4-12 UNF-3B	M33 X 2-4H	1 3/4-12 UNF-3B	M42 X 2-4H	2 3/4-8 UNF-3B	M72 X 2-4H
	.87 in deep	22.1 mm deep	1.40 in deep	35.6 mm deep	1.75 in deep	44.5 mm deep	2.75 in deep	69.8 mm deep

SPECIFICATIONS

PARAMETERS	MODEL				
	1110	1110	1120	1132	1140
	CAPACITY				
U.S. Models (lbf)	300, 500, 1K, 2K, 3K	5K, 10K	25K, 50K	100K	200K
Metric Models (kN)	1.5, 2.5, 5, 10	25, 50	100, 250	450	900
ACCURACY – (MAX ERROR)					
Static Error Band-% FS	±0.02	±0.03	±0.04	±0.05	±0.06
Nonlinearity-% FS	±0.03	±0.04	±0.04	±0.05	±0.06
Hysteresis-% FS	±0.02	±0.04	±0.05	±0.05	±0.06
Nonrepeatability-% RO	±0.01	±0.01	±0.01	±0.01	±0.01
Creep, in 20 min-%	±0.025	±0.025	±0.025	±0.025	±0.025
Side Load Sensitivity-%	±0.1	±0.1	±0.1	±0.1	±0.1
Eccentric Load Sensitivity-%/in	±0.1	±0.1	±0.1	±0.1	±0.1
TEMPERATURE					
Compensated Range-°F	15 to 115	15 to 115	15 to 115	15 to 115	15 to 115
Compensated Range-°C	-10 to 45	-10 to 45	-10 to 45	-10 to 45	-10 to 45
Operating Range-°F	-65 to 200	-65 to 200	-65 to 200	-65 to 200	-65 to 200
Operating Range-°C	-55 to 90	-55 to 90	-55 to 90	-55 to 90	-55 to 90
Effect on Zero-%RO/°F – MAX	±0.0004	±0.0004	±0.0004	±0.0004	±0.0004
Effect on Zero-%RO/°C – MAX	±0.0007	±0.0007	±0.0007	±0.0007	±0.0007
Effect on Output-%/°F – MAX	±0.0008	±0.0008	±0.0008	±0.0008	±0.0008
Effect on Output-%/°C – MAX	±0.0015	±0.0015	±0.0015	±0.0015	±0.0015
ELECTRICAL					
Rated Output-mV/V (Nominal)	2.0	4.0	4.0	4.0	4.0
Excitation Voltage-VDC MAX	20	20	20	20	20
Bridge Resistance-Ohm (Nominal)	350	350	350	350	350
Zero Balance-% RO	±1.0	±1.0	±1.0	±1.0	±1.0
Insulation Resistance-Megohm	5000	5000	5000	5000	5000
MECHANICAL					
Safe Overload-% CAP	±150	±150	±150	±150	±150
Deflection @ RO-inch	0.002	0.004	0.004	0.006	0.012
Deflection @ RO-mm	0.05	0.10	0.10	0.15	0.20
Base Part Number (Ref) (Metric)	B101 (m)	B102 (m)	B103 (m)	B112 (m)	B105 (m)
Natural Frequency-kHz	2.7, 3.5, 4.9, 7.0, 8.5	4.7, 6.6	4.6, 5.0	4.0	3.5
Weight-lb	3.3	7.3	21.5	52	146
Weight-kg	1.5	3.3	9.8	24	66
Connector	PC04E-10-6P	PC04E-10-6P	PC04E-10-6P	PC04E-10-6P	PC04E-10-6P
Calibration	T & C	T & C	T & C	T & C	T & C

OPTIONS

Compression Overload Protection
 Integral 10 ft Cable
 Bayonet Connector
 Multiple Bridge
 Standardized Output
 Connector Protection
 Transducer Electronic Data Sheet (TEDS)

ACCESSORIES

Mating Connector
 Instrumentation
 Loading Hardware

Consult factory for more technical information

STANDARD CONFIGURATIONS

10 ft Integral Cable (11xxAJ-nn)
 <or> PC04E-10-6P Connector (11xxAF-nn)
 <or> PTO2E-10-6P Bayonet Connector (11xxACK-nn)

