

# P420 SERIES

## 4-20 mA ANALOG OUTPUT



### Two wire 4-20 mA Transmitter

The UniMeasure P420 position transducer provides a 4 to 20 mA output signal using a potentiometric sensor. Since the transmitter is loop powered, an assembled system consists of a power supply, current monitor, and transmitter all connected in series. The P420 is particularly insensitive to electrically noisy environments. Zero and span adjustments allow setting the 4 mA position within the first 30% of total travel and setting the 20 mA position within 80% to 100% of total travel. The devices may be powered by a supply voltage in the range of 9 to 35 VDC and with a total loop resistance per the graph below.

### SPECIFICATIONS

#### General

Linearity	
2", 3", 4" & 5" Ranges.....	±0.30% Full Scale
10", 15", 20" & 25" Ranges.....	±0.20% Full Scale
All other ranges .....	±0.15% Full Scale
Repeatability <sup>1</sup> .....	±0.015% Full Scale
Resolution .....	Essentially Infinite
Construction .....	Aluminum Cover & Baseplate
Sensing Device.....	Precision Potentiometer
Connector .....	MS3102A-14S-6P
Wire Rope.....	Ø.016 Stainless Steel
Wire Rope Tension .....	See Supplemental Data <sup>3</sup> , Table 7
Wire Rope Inbound Acceleration.....	See Supplemental Data <sup>3</sup> , Table 7
Weight.....	1.0 lb. (0.45 Kg) to 50" 1.4 lb. (0.63 Kg) 60" & 80"
Dimensional Information.....	See Supplemental Data <sup>3</sup> , Fig. 1 & 2
Options and Accessories.....	See Supplemental Data <sup>3</sup>

#### Environmental

Thermal Coefficient of	
sensing element .....	±100 PPM/°C max.
Operating temperature .....	-40°C to 95°C
Operating humidity .....	95% R.H. max. non-condensing
Vibration .....	15 G's 0.1 ms max.
Shock.....	50 G's 0.1 ms max.
Ingress Protection.....	NEMA 1, IP-40

#### Electrical

Output.....	4 to 20 mA
Load Resistance (Total Loop).....	See Graph Below
Excitation Voltage .....	9 to 35 VDC <sup>2</sup>
Min. Supply Voltage .....	(.02 x Load Res.) + 9 VDC
Insulation resistance.....	100 Megohms min. at 100 VDC
Adjustment Range	
Zero .....	0 to 30% of Range
Span .....	80% to 100% of Range
Protection .....	Reversed Polarity

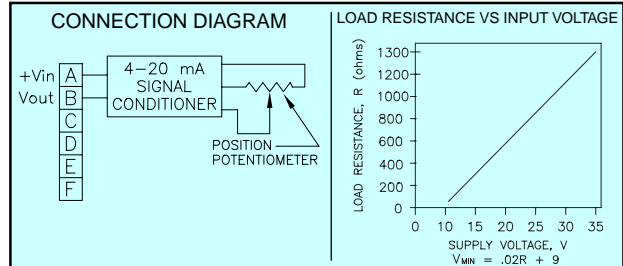

#### FOOTNOTES TO SPECIFICATIONS

1. Moving to the same position from the same direction.
2. Voltage required at transducer.
3. Supplemental Data section located at end of Standard Series pages.

## Model Number Configuration

P420-

Range	
2.....	2" (50 mm)
3.....	3" (75 mm)
4.....	4" (100 mm)
5.....	5" (125 mm)
10.....	10" (250 mm)
15.....	15" (390 mm)
20.....	20" (500 mm)
25.....	25" (640 mm)
30.....	30" (750 mm)
40.....	40" (1000 mm)
50.....	50" (1250 mm)
60.....	60" (1500 mm)
80.....	80" (2000 mm)

Wire Rope	
* .....	Ø.016 (0,4 mm) Stainless Steel
NJC .....	Ø.018 (0,45 mm) Nylon Jacketed Stainless Steel

Wire Rope Tension	
* .....	Standard (50 G units to 50")
004.....	Reduced (see Table 7 for value)
HG .....	Increased (100G on units with ranges from 2" to 50")

Wire Rope Exit Direction	
* .....	Top Exit
CES .....	Side Exit
CEB .....	Bottom Exit

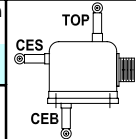

Dust Wiper Option	
* .....	No dust wiper
DS.....	Dust Wiper Installed

Electrical Interface	
* .....	Mating Connector Included
TS .....	Terminal Strip
L3M .....	Mating Conn with 3 m (10') electrical cable
L4M .....	Mating Conn with 4 m (13.5') electrical cable
L5M .....	Mating Conn with 5 m (16.5') electrical cable
L6M .....	Mating Conn with 6 m (20') electrical cable
L7M .....	Mating Conn with 7 m (23') electrical cable

Connector Location	
* .....	Standard Location
S3 .....	Rear Side

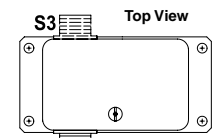

Electrical Output Polarity	
* .....	Standard (increasing output as wire rope is extended)
R .....	Reversed (decreasing output as wire rope is extended)

#### NOTE

- 1) \*—Asterisk items are standard configuration. No option designator is required.
- 2) Shaded options available at additional cost.
- 3) See Supplemental Data for options.

Example  
**P420-50-NJC-R-S3**

### ADDITIONAL OPTIONS

OPTION	OPTION DESIGNATOR	DESCRIPTION
Nylon jacketed wire rope	<b>NJC</b>	Replaces standard stainless steel wire rope with Ø.018 nylon jacketed wire rope. Increases wire rope life dramatically but may increase non-linearity by as much as ±0.05% of full scale.
Reduced Wire Rope Tension	<b>004</b>	Reduces the overall tension in the wire rope and increases wire rope life. Dynamic response of the transducer is reduced due to the reduced inbound acceleration capability.
Increased Wire Rope Tension	<b>HG</b>	Increases tension in the wire rope which increases the dynamic response of the transducer. On selected units with range of 50" (1250 mm) or less, inbound acceleration capability is 100G's. Wire rope life may be adversely affected by the HG option.
Dust wiper	<b>DS</b>	Lubricated wiper strips dust and debris from wire rope as it retracts into case. Adds 0.36" (9 mm) height to wire rope exit location.
Terminal strip	<b>TS</b>	Replaces connector with a terminal strip.
Reversed output	<b>R</b>	Output is at a maximum when wire rope is fully retracted. Output decreases as wire rope is extended. Does not apply to velocity signal.
Non-standard potentiometer (applies to PA series only)	<b>PXK</b>	Replace "X" in option designator with required potentiometer value in K ohms. Non-standard potentiometer linearity is as follows: Ranges 0 to 2" to 0 to 5" ..... ±1.00% of full scale Ranges 0 to 10" to 0 to 25" ..... ±0.50% of full scale Ranges 30" and above ..... ±0.25% of full scale Note: This option is subject to potentiometer availability.

### ACCESSORIES

#### 10067 Auxiliary Wire Rope Extension Kit

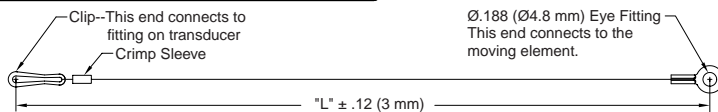

The auxiliary wire rope extension may be used to facilitate mounting the transducer remotely from the measurement point. The clip on the extension attaches to the eye fitting on the transducer. The eye fitting on the opposite end which is identical to the fitting on the transducer mounts to the moving element. The extension kit is also available with the clip end unterminated for situations where it is more convenient to size the wire rope length during installation. The clip and crimp sleeve are included as loose parts for user termination.

#### Dimension "L"

Specify dimension "L" in centimeters to the **nearest whole centimeter**.  
 Note 1. 1 cm = 0.394", 1 inch = 2.54 cm  
 Note 2. Shortest length "L" is 5 cm (approximately 2").

**10067- CM-**

\* ..... Completed kit (no designator required)

U ..... Unterminated clip end  
 (clip and crimp sleeve included in kit)

\* Leave blank. No designator required.

#### Replacement Wire Rope Kit

The replacement Wire Rope Kit includes a new wire rope with all end terminations, wire rope guide, felt dust wiper where applicable and installation instructions. To order, replace 'xx' in the part number with the applicable measurement range in inches.

10107-xx Replacement Wire Rope Kit—Standard Ø.016" stainless steel wire rope.

10108-xx Replacement Wire Rope Kit—NJC option, Ø.018" nylon jacketed stainless steel wire rope.

10127-xx Replacement Wire Rope Kit—DS option, Standard Ø.016" stainless steel wire rope with dust wiper.

10128-xx Replacement Wire Rope Kit—NJC and DS options, Ø.018" nylon jacketed stainless steel wire rope with dust wiper.

### ADDITIONAL SPECIFICATIONS

#### TABLE 7

PA, PB, P420, P510, P1010 SERIES						EP Series			V & VP Series					
Range Designator	Range		Wire Rope Standard Tension (Nominal)		Wire Rope Standard Acceleration	Wire Rope Reduced Tension (004 option)		Wire Rope Reduced Acceleration (004 option)		Wire Rope Reduced Tension (004 option)		Wire Rope Reduced Acceleration (004 option)		
	(in)	(mm)	(oz)	(N)	(G's)	(oz)	(N)	(oz)	(N)	(oz)	(N)	(G's)		
2	2	50	34	9.5	>50	16	4.4	28	—	—	16	4.4	14	
3	3	75	24	6.7	>50	14	3.9	16	—	—	14	3.9	15	
4	4	100	24	6.7	>50	11	3.1	12	—	—	11	3.1	15	
5	5	125	34	9.5	>50	8	2.2	7	—	—	8	2.2	6	
10	10	250	34	9.5	>50	16	4.4	28	16	4.4	19	16	4.4	14
15	15	390	24	6.7	>50	14	3.9	16	—	—	14	3.9	15	
20	20	500	24	6.7	>50	11	3.1	12	—	—	11	3.1	14	
25	25	640	34	9.5	>50	8	2.2	7	8	2.2	7	8	2.2	6
30	30	750	24	6.7	>50	14	3.9	16	—	—	14	3.9	15	
40	40	1000	24	6.7	>50	11	3.1	12	—	—	11	3.1	12	
50	50	1250	34	9.5	>50	8	2.2	7	8	2.2	7	8	2.2	5
60	60	1500	24	6.7	27	7	1.8	2	7	1.8	5	7	1.8	6
80	80	2000	19	5.3	16	5	1.4	2	5	1.4	2	5	1.4	3

### DIMENSIONAL INFORMATION

#### PA, PB, P420, P510, P1010, EP & V Series

##### RANGES TO 50" (1250 mm)

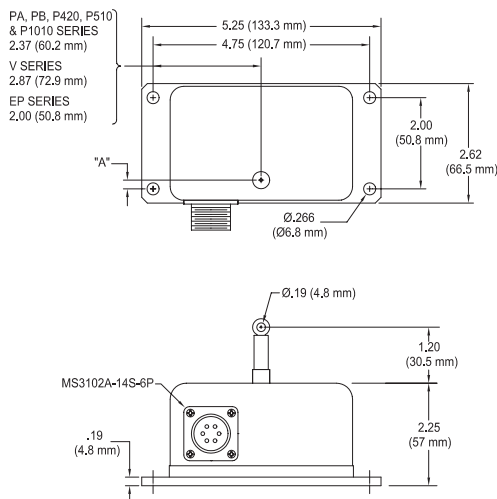

Figure 1

PA, PB, P420, P510, P1010, V Series		
RANGE	(in)	"A" (mm)
2", 10"	0.66	16.8
3", 15", 30"	0.51	12.9
4", 20", 40"	0.35	8.8
5", 25", 50"	0.19	4.8
60"	See Figure 2	
80"	See Figure 2	

EP Series		
MODEL	(in)	"A" (mm)
EP-10	0.68	17.4
EP-25, EP-50	0.21	5.3
EP-60	See Figure 2	
EP-80	See Figure 2	
EPM-250	0.68	17.4
EPM-1250	0.21	5.3

##### RANGES TO 60" (1500 mm) and 80" (2000 mm)

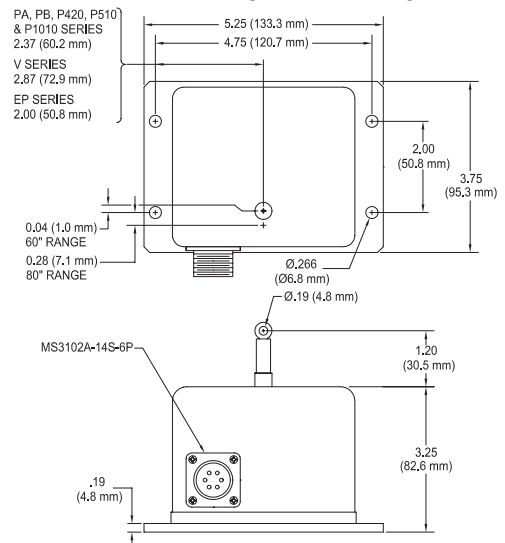

Figure 2