

JX-EP SERIES

DIGITAL OUTPUT

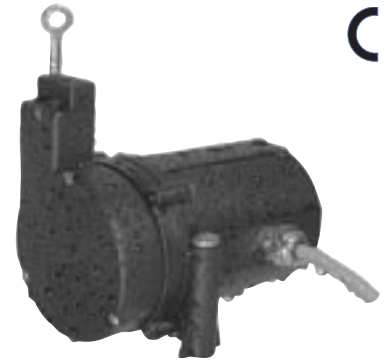

The UniMeasure JX-EP series linear position transducer with digital output is oriented for use in moderate duty applications in hostile wet or dry environments. The chemical resistant thermoplastic case of the transducer with integral dust wiper is factory configurable to NEMA 12 (IP-52) for dust protection or to NEMA 4X (IP-65) for applications where exposure to washdown, rain, oil and other liquids may occur. The sealed case is achieved through the use of o-rings and a low friction shaft seal. The standard electrical connection includes a sealed bulkhead fitting and multi-conductor electrical cable. An optional cable to cable connector with mating connector may be added to the electrical cable. As a convenience, optional connector locations on the transducer body are offered. The wire rope exit direction may be specified at time of order or may be user adjusted at time of installation. The standard output of the unit is a TTL level two channel square wave in quadrature. Optional outputs include line driver and push-pull circuits.

SPECIFICATIONS

General

Measurement Range	See Range Table below
Sensing Device	Digital Encoder
Nominal Resolution	
10" range	445 counts/inch, 17.5 counts/mm
15", 30" range	327 counts/inch, 12.9 counts/mm
20", 40" range	246 counts/inch, 9.7 counts/mm
25", 50" range	198 counts/inch, 7.8 counts/mm
60" range	166 counts/inch, 6.5 counts/mm
80" range	126 counts/inch, 5.0 counts/mm
Linearity	±0.10% Full Scale
Repeatability	
(in times 1 counting mode)	±1 Count, ranges to 25" ±2 Counts, ranges 30" to 80"
Construction	Thermoplastic Body
Wire Rope	Ø.018 (0.46 mm) Jacketed Stainless Steel
Wire Rope Tension	See Supplemental Data ¹ Weight
6.3 oz. (180 gm)	
Connection	24 AWG Shielded Electrical Cable

	(to wire rope replacement)
Ranges 10" to 25"	1,000,000 full stroke cycles
Ranges 30" to 80"	500,000 full stroke cycles
Electrical	
Excitation Voltage	5.00 ±0.25 VDC
Output	2 channel square wave in quadrature TTL level current sinking with 65 KΩ pullups
Environmental	
Operating Temperature	-40°C to 70°C
Storage Temperature	-40°C to 80°C
Operating Humidity	95% R.H. non-condensing IP-52 case 100% R.H. IP-65 case
Vibration	20 G's maximum
Ingress Protection	NEMA 12 or 4X, IP-52 or 65

FOOTNOTES TO SPECIFICATIONS

1. Supplemental Data section located at end of JX Series pages.

Model Number Configuration

JX-EP- - - - - 0 -

Range	
10	10" (250 mm)
15	15" (380 mm)
20	20" (500 mm)
25	25" (625 mm)
30	30" (750 mm)
40	40" (1000 mm)
50	50" (1250 mm)
60	60" (1500 mm)
80	80" (2000 mm)

Wire Rope	
N	Ø.018" nylon jacketed stainless steel

Wire Rope Tension	
1	Standard (See Table A and Table B for values)

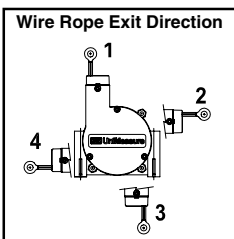

Ingress Protection	
1	IP-65 (NEMA 4X) dust and spraying water protection
2	IP-52 (NEMA 12) dust and dripping liquids

Electrical Output	
1	5 VDC current sinking 2 channel
2	5 VDC current sinking differential line drive
3	5 VDC push-pull differential line drive
4	8 to 28 VDC current sinking differential line drive
5	8 to 28 VDC push-pull differential line drive

See TABLE 3, Electrical Output Options, Page 12 for waveform and output stage configuration.

Connector	
U	No connector
C	Cable to cable connector with mating connector
K	Cable to cable connector, no mating connector*

* For mating connector with electrical cable, order P/N 10325-xxM where xx is the required cable length in meters.

Electrical Cable	
P	150 mm (6") pigtail
1	1 m (3')
2	2 m (6.5')
3	3 m (10')
4	4 m (13.5')
5	5 m (16.5')

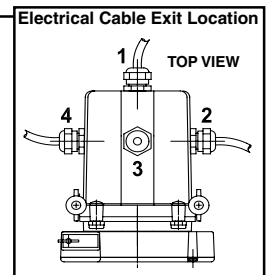

NOTE
1) Shaded options available at additional cost.

Example
JX-EP-50-N11-110-42U

DIMENSIONAL INFORMATION

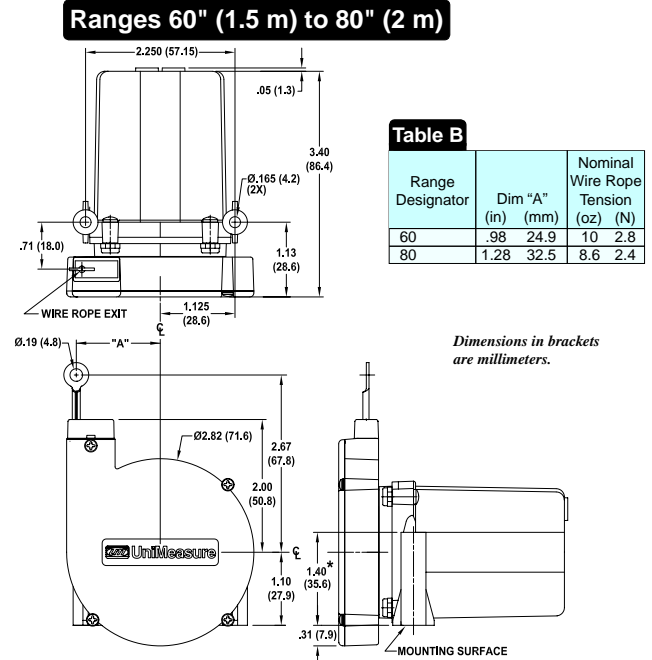
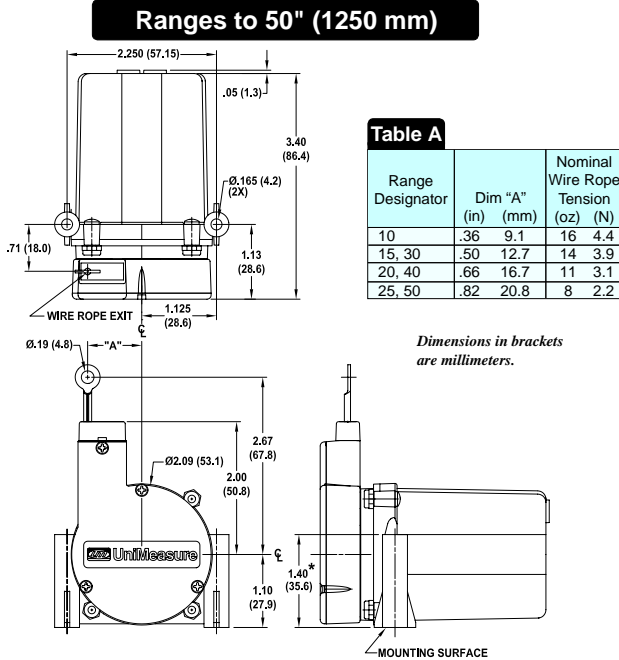
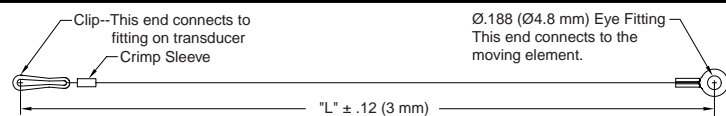

TABLE 3—Electrical Output Options—JX-EP Series

Option	Output Type	Output Stage	Waveform
1	5 VDC TTL Two Channel Current Sinking Two channels in quadrature with 65KΩ internal pullup resistors. 5 VDC input voltage		
2	5 VDC TTL Current Sinking Differential Line Drive Current sinking line drive output. 2KΩ internal pullup resistors. 5 VDC input voltage		
3	5 VDC Push-Pull Differential Line Drive Push-Pull, current sourcing and current sinking output. 5 VDC input voltage. Output is compliant with requirements of TIA/EIA-422-B.		
4	8 to 28 VDC Current Sinking Differential Line Drive Current sinking line drive output with 10KΩ internal pullup resistors. 8 to 28 VDC input voltage		
5	8 to 28 VDC Push-Pull Differential Line Drive Push-Pull, current sourcing and current sinking output. 8 to 28 VDC input voltage.		

Accessory—10067 Auxiliary Wire Rope Extension Kit



The auxiliary wire rope extension may be used to facilitate mounting the transducer remotely from the measurement point. The clip on the extension attaches to the eye fitting on the transducer. The eye fitting on the opposite end which is identical to the fitting on the transducer mounts to the moving element. The extension kit is also available with the clip end unterminated for situations where it is more convenient to size the wire rope length during installation. The clip and crimp sleeve are included as loose parts for user termination.

10067- CM-

- * Completed kit (no designator required)
- U Unterminated clip end (clip and crimp sleeve included in kit)
- * Leave blank. No designator required.

Dimension "L"
Specify dimension "L" in centimeters to the **nearest whole centimeter**.
Note 1. 1 cm = 0.394", 1 inch = 2.54 cm
Note 2. Shortest length "L" is 5 cm (approximately 2").