



# HX-P420 SERIES

## 4 to 20 mA OUTPUT



The HX-P420 position transducer provides a 4 to 20 mA output signal with a potentiometric sensor. The HX-P420 is particularly advantageous in electrically noisy environments. Since the transmitter is loop powered, an assembled system consists of a power supply, current monitor, and transmitter all connected in series. Zero and span adjustments allow setting the 4 mA position within the first 30% of total travel and setting the 20 mA position within 80% to 100% of total travel. The HX-P420 may be powered with a supply voltage in the range of 9 to 35 VDC subject to the total loop resistance.

### SPECIFICATIONS

#### General

Available Measurement Ranges .. See Supplemental Data<sup>1</sup>, Table 12  
 Connector ..... MS3102E-14S-6P  
 Mating Connector (included)..... MS3106E-14S-6S

#### Performance

Linearity  
 2", 3", 4", 5" & 6" Ranges ..... ±0.30% Full Scale  
 10", 15", 20" & 25" Ranges ..... ±0.20% Full Scale  
 All other ranges ..... ±0.15% Full Scale  
 Repeatability ..... ±0.015% Full Scale  
 Resolution ..... Essentially Infinite

#### Electrical

Output ..... User Adjustable 4 to 20 mA  
 Excitation Voltage ..... 9 to 35 VDC  
 Min. Supply Voltage ..... (.02 x Load Res.) + 9 VDC  
 Insulation Resistance ..... 100 Megohms min. at 100 VDC  
 Adjustment Range  
 4 mA ..... 0 to 30% of Range  
 20 mA ..... 80% to 100% of Range  
 Protection ..... Reversed Polarity

#### Environmental

Thermal Coefficient of Sensing Element ..... ±100 PPM/°C Max.  
 Operating Temperature ..... -40°C to 95°C  
 Operating Humidity ..... 100%  
 Shock ..... 50 G @ 0.1 ms Max.  
 Vibration ..... 10 Hz to 2000 Hz, 15 G peak  
 Ingress Protection  
 Exclusive of Wire Rope Area NEMA 4 (IP-65)  
 Optional Ingress Protection..... NEMA 6 (IP-68)

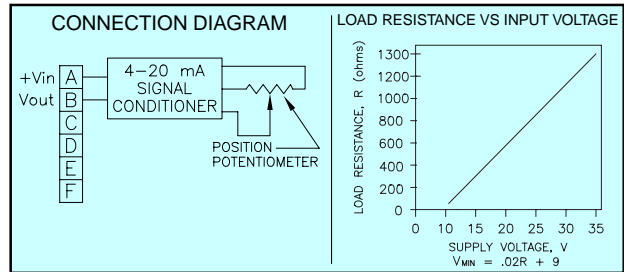

#### FOOTNOTES TO SPECIFICATIONS

1. Supplemental Data section located at end of HX Series pages.

## Model Number Configuration

**HX-P420-** - - - - -

**Range**  
Select measurement range from Supplemental Data, Table 12. Insert corresponding Measurement Range Designator

**Wire Rope**  
\* ..... Stainless Steel (See Supplemental Data, Table 12)  
**NJC** ..... Ø.018 (0,45 mm) Nylon Jacketed Stainless Steel Ranges to 80" (2m) only.  
**NJC037** ..... Ø.037 (0,94 mm) Nylon Jacketed Stainless Steel Ranges 100" (2.5m) to 500" (12.7m) only.

**Wire Rope Tension**  
\* ..... Standard  
**004** ..... Reduced (Ranges to 80" only)

**Wire Rope Exit Direction**  
\* ..... Top Exit  
**E1** ..... Side Exit (Left)  
**E2** ..... Side Exit (Right)  
**E3** ..... Bottom Exit

**Housing**  
\* ..... NEMA 4 (IP-65) Aluminum  
**N6** ..... NEMA 6 (IP-68) Aluminum  
**SS** ..... NEMA 6 (IP-68) Corrosion Resistant Stainless Steel and Non-Metallic Construction



**Electrical Interface**  
 \* ..... Mating Connector Included (See note 1 below)  
**L3M** ..... 3 m (10') electrical cable (See note 2 below)  
**L4M** ..... 4 m (13.5') electrical cable (See note 2 below)  
**L5M** ..... 5 m (16.5') electrical cable (See note 2 below)  
**L6M** ..... 6 m (20') electrical cable (See note 2 below)  
**L7M** ..... 7 m (23') electrical cable (See note 2 below)  
 1. Applies to NEMA 4 Housing option only. Does not apply to N6 or SS Housing options.  
 2. Select one of options L3M through L7M when electrical cable is required with mating connector when Housing option NEMA 4 is also selected. Select one of options L3M through L7M when Housing option N6 or SS is selected. Connector is **not** available with Housing option N6 or SS.

**Electrical Output Polarity**  
 \* ..... Standard (increasing output as wire rope is extended)  
**R** ..... Reversed (decreasing output as wire rope is extended)

**NOTE**  
 1) \*—Asterisk items are standard configuration. No option designator is required.  
 2) Shaded options available at additional cost.  
 3) See Supplemental Data for options.

**Example**  
**HX-P420-50-NJC-004-L7M**

### ADDITIONAL OPTIONS

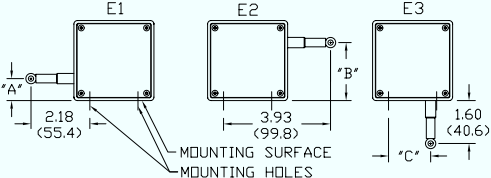
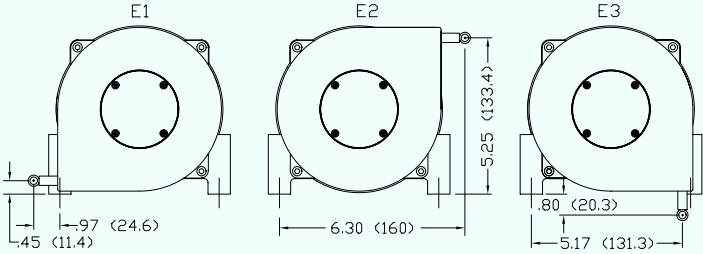
OPTION	OPTION DESIGNATOR	DESCRIPTION																												
Nylon jacketed wire rope (Ranges to 80" only)	<b>NJC</b>	Replaces standard stainless steel wire rope with Ø.018 nylon jacketed wire rope. This option increases wire rope life dramatically but may increase non-linearity by as much as ±.05% of full scale.																												
Nylon jacketed wire rope (Ranges 100" to 500" only)	<b>NJC037</b>	Replaces standard stainless steel wire rope with Ø.037 nylon jacketed wire rope.																												
Reversed output	<b>R</b>	Output is at a maximum when wire rope is fully retracted. Output decreases as wire rope is extended. Does not apply to velocity signal.																												
NEMA 6, IP-68 capability	<b>N6</b>	 Connector is replaced with a bulkhead fitting and a designated length of urethane jacketed, shielded, twisted pair cable. Retraction mechanism and electrical components are sealed to NEMA 6, IP-68 capability. No connector.																												
Stainless steel construction	<b>SS</b>	All external anodized aluminum parts of transducer are replaced with stainless steel and corrosion resistant plastic. Transducer is sealed to NEMA 6, IP-68 capability. Urethane jacketed, shielded, twisted pair cable exits unit. No connector. 																												
Non-standard potentiometer (Applies to HX-PA only)	<b>PXK</b>	Replace "X" in option designator with required potentiometer value in K ohms. Non-standard potentiometer linearity is as follows: Ranges 0 to 2" to 0 to 5" ..... ±1.00% of full scale Ranges 0 to 10" to 0 to 25" ..... ±0.50% of full scale Ranges 30" and above ..... ±0.25% of full scale Note: This option is subject to potentiometer availability.																												
Alternate wire rope exit Measurement ranges to 80" (2.0 m)	<b>E1, E2, E3</b>	 <table border="1" data-bbox="662 1346 1149 1556"> <thead> <tr> <th>RANGE</th> <th>"A"</th> <th>"B"</th> <th>"C"</th> </tr> </thead> <tbody> <tr> <td>2", 10"</td> <td>1.12 (28.4)</td> <td>1.79 (45.5)</td> <td>1.21 (30.7)</td> </tr> <tr> <td>3", 15", 30"</td> <td>.96(24.4)</td> <td>1.95 (49.5)</td> <td>1.37 (34.8)</td> </tr> <tr> <td>4", 20", 40"</td> <td>.80 (20.3)</td> <td>2.11 (53.6)</td> <td>1.53 (38.9)</td> </tr> <tr> <td>5", 25", 50"</td> <td>.64 (16.3)</td> <td>2.27 (57.7)</td> <td>1.69 (42.9)</td> </tr> <tr> <td>6", 60"</td> <td>.49 (12.4)</td> <td>2.42 (61.5)</td> <td>1.84 (46.7)</td> </tr> <tr> <td>80"</td> <td>.25 (6.4)</td> <td>2.66 (67.6)</td> <td>2.08 (52.8)</td> </tr> </tbody> </table> <p>Dimensions in brackets are millimeters.</p>	RANGE	"A"	"B"	"C"	2", 10"	1.12 (28.4)	1.79 (45.5)	1.21 (30.7)	3", 15", 30"	.96(24.4)	1.95 (49.5)	1.37 (34.8)	4", 20", 40"	.80 (20.3)	2.11 (53.6)	1.53 (38.9)	5", 25", 50"	.64 (16.3)	2.27 (57.7)	1.69 (42.9)	6", 60"	.49 (12.4)	2.42 (61.5)	1.84 (46.7)	80"	.25 (6.4)	2.66 (67.6)	2.08 (52.8)
RANGE	"A"	"B"	"C"																											
2", 10"	1.12 (28.4)	1.79 (45.5)	1.21 (30.7)																											
3", 15", 30"	.96(24.4)	1.95 (49.5)	1.37 (34.8)																											
4", 20", 40"	.80 (20.3)	2.11 (53.6)	1.53 (38.9)																											
5", 25", 50"	.64 (16.3)	2.27 (57.7)	1.69 (42.9)																											
6", 60"	.49 (12.4)	2.42 (61.5)	1.84 (46.7)																											
80"	.25 (6.4)	2.66 (67.6)	2.08 (52.8)																											
Alternate wire rope exit Measurement ranges 100" (2.5 m) and greater.	<b>E1, E2, E3</b>	 <p>Dimensions in brackets are millimeters.</p>																												

Specifications subject to change without notice.

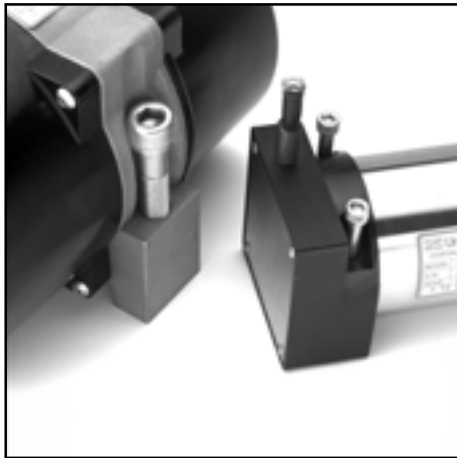

Typical HX mounting bolts.

### MECHANICAL SPECIFICATIONS

#### Mechanical Specifications

- Available Measurement Ranges..... See Table 12
- Construction
  - Ranges 80" (2 m) and under ..... Anodized Aluminum Mounting Base, Stainless Steel & Anodized Aluminum Housing
  - Ranges 100" (2.5 m) and greater ..... Stainless Steel Mounting Base High Impact, Corrosion Resistant Thermoplastic Housings
- Wire Rope Tension ..... See Table 12
- Wire Rope Diameter ..... See Table 12
- Weight..... See Table 12
- Connector..... MS3102A-14S-6P
- Mating Connector (included) ..... MS3106E-14S-6S
- Optional NEMA 6 Capability ..... Bulkhead fitting with shielded, twisted pair cable

Use value from this column to indicate overall measurement range

Check mark indicates available measurement range

# TABLE 12

MEASUREMENT RANGE DESIGNATOR	STANDARD MEASUREMENT RANGES		APPLICABLE SERIES			WIRE ROPE TENSION (NOMINAL)		WIRE ROPE DIAMETER		WEIGHT		Product Photo
	(in)	(mm)	HX-PA HX-PB HX-P420 HX-P510 HX-P1010	HX-EP	HX-V HX-VP	(oz)	(N)	(in)	(mm)	(lb)	(Kg)	
2	2	50	4	-	4	34	9.4	.016	0.4	2	0.9	
3	3	75	4	-	4	24	6.7	.016	0.4	2	0.9	
4	4	100	4	-	4	24	6.7	.016	0.4	2	0.9	
5	5	125	4	-	4	19	5.3	.016	0.4	2	0.9	
6	6	150	4	-	4	24	6.7	.016	0.4	2	0.9	
10	10	250	4	4	4	34	9.4	.016	0.4	2	0.9	
15	15	390	4	-	4	24	6.7	.016	0.4	2	0.9	
20	20	500	4	-	4	24	6.7	.016	0.4	2	0.9	
25	25	640	4	4	4	19	5.3	.016	0.4	2	0.9	
30	30	750	4	-	4	24	6.7	.016	0.4	2	0.9	
40	40	1000	4	-	4	24	6.7	.016	0.4	2	0.9	
50	50	1250	4	4	4	19	5.3	.016	0.4	2	0.9	
60	60	1500	4	4	4	24	6.7	.016	0.4	2	0.9	
80	80	2.0m	4	4	4	21	5.8	.016	0.4	2	0.9	
100	100	2.5m	4	4	4	36	10.0	.024	0.6	6.8	3.1	
120	120	3.0m	4	4	4	36	10.0	.024	0.6	6.8	3.1	
150	150	3.8m	4	4	4	36	10.0	.024	0.6	6.8	3.1	
200	200	5.0m	4	4	4	36	10.0	.024	0.6	6.8	3.1	
250	250	6.3m	4	4	4	36	10.0	.024	0.6	6.8	3.1	
300	300	7.5m	4	4	4	36	10.0	.024	0.6	6.8	3.1	
350	350	8.8m	4	4	4	36	10.0	.024	0.6	6.8	3.1	
400	400	10.0m	4	4	4	36	10.0	.024	0.6	6.8	3.1	
500	500	12.5m	4	4	4	36	10.0	.024	0.6	8.6	3.9	
600	600	15.2m	4	4	4	36	10.0	.024	0.6	8.6	3.9	
800	800	20.3m	4	4	4	36	10.0	.024	0.6	8.6	3.9	
1000	1000	25.4m	4	4	-	36	10.0	.024	0.6	12.0	5.4	
1200	1200	30.4m	4	4	-	36	10.0	.024	0.6	12.3	5.6	
1600	1600	40.6m	4	4	-	36	10.0	.024	0.6	14.1	6.4	
1800	1800	45.7m	4	4	-	36	10.0	.021	0.6	15.9	7.2	
2000	2000	50.8m	4	4	-	36	10.0	.021	0.5	16.3	7.4	

Specifications subject to change without notice.

### DIMENSIONAL INFORMATION

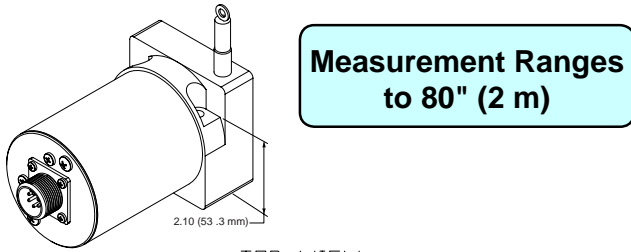

**Measurement Ranges to 80" (2 m)**

**Measurement Ranges 100" (2.5 m) and greater**

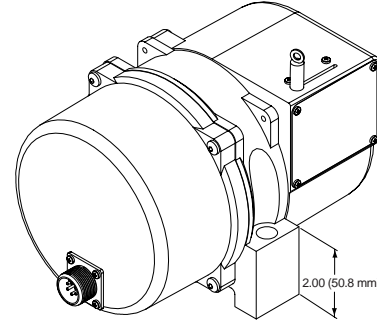
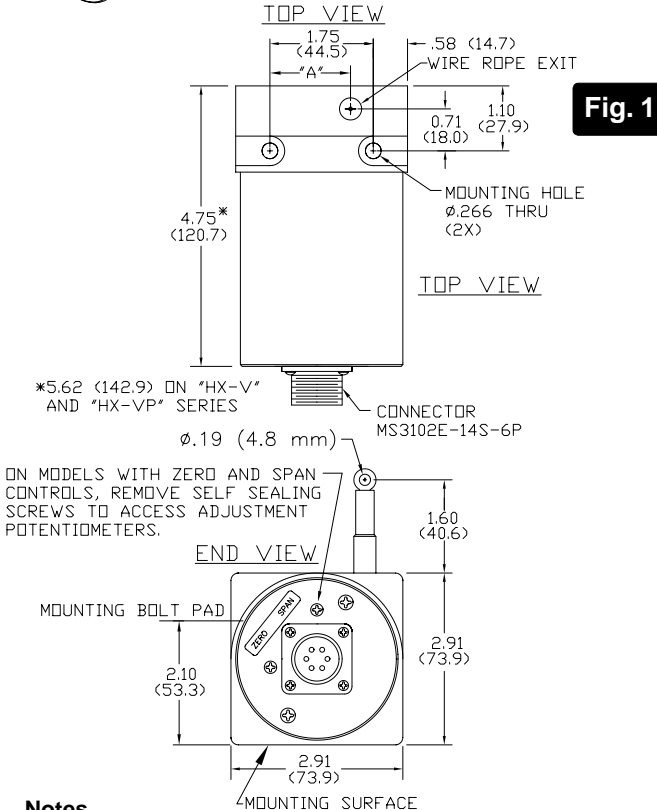

**Fig. 2**

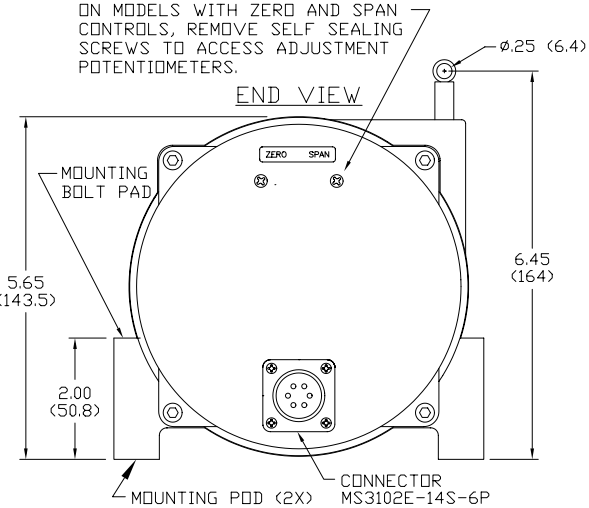
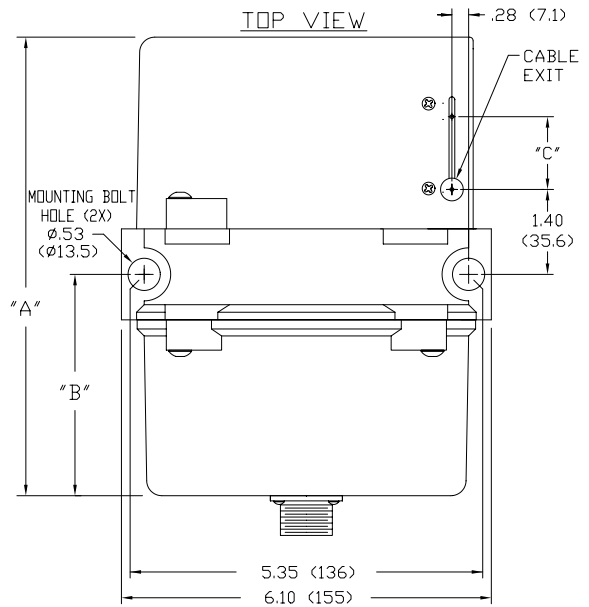

**Notes**

1. Transducer mounts with Ø.25 or M6 socket head cap bolts.

**Table 13**

RANGE	"A"
2", 10"	1.21 (30.7)
3", 15", 30"	1.37 (34.8)
4", 20", 40"	1.53 (38.9)
5", 25", 50"	1.69 (42.9)
60"	1.84 (46.7)
80"	2.08 (52.8)

**Table 14**

RANGE	DIM "A"	DIM "B"
Ranges to 800"	7.70 (196)	3.80 (97)
1000" to 2000"	11.0 (280)	5.60 (142)

**Notes**

1. Transducer mounts with Ø.50 or M12 socket head cap bolts.

2. Dimension "C" is the cable offset that occurs as the cable is extended from the transducer.

For "C" in inches,  $C = .0016 \times E$  where E = extension in inches.

For "C" in millimeters,  $C = .0016 \times E$  where E = extension in mm.

**Dimensions in brackets are millimeters.**

Specifications subject to change without notice.