

01027 Series

STEERING EFFORT SENSOR

This steering effort transducer was designed to evaluate steering torque requirements of non-airbag equipped, new and existing steering systems and components used in automobile, trucks, buses, and material handling equipment. Quantitative evaluations of steering systems, steering geometries, tire interactions, and safety factors are made using this device. The steering effort sensor is equipped with a 14" steering wheel. This is fastened to the existing steering wheel by means of a fixed or optional adjustable 3 point clamp assembly. For direct steering shaft attachment, a custom adapter plate is available.



SPECIFICATIONS

Capacities.....	100 to 3,000 in.- lbs.
Overload capacity.....	150% of F.S.
Output at full scale load.....	2.0 mV/V nominal
Non-linearity.....	0.10% of F.S.
Hysteresis.....	0.10% of F.S.
Zero balance.....	1% of F.S.
Compensated temperature.....	70 to 170°F
Useable temperature.....	-65 to +250°F
Temperature effect on zero.....	0.002% of F.S./°F
Temperature effect on span.....	0.002% of Rdg./°F
Bridge resistance.....	350 Ohms
Excitation voltage, maximum.....	20 Vdc
Excitation/Signal transmission.....	Slip ring coupled
Resolution	Infinite
Encoder	Resistive
Encoder range	10 turns - 10K Ohms

OPTIONAL FEATURES

- High level analog torque signal output
- Steering column adapter plates
- Replace 10kohm potentiometer with optical encoder
- Encoder to analog convertor

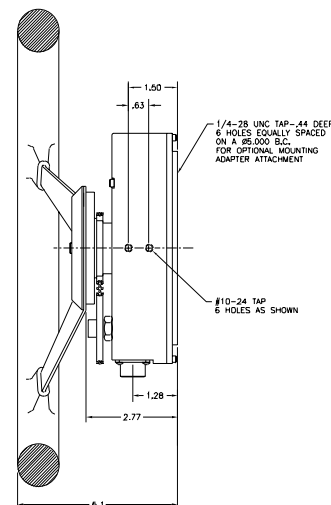
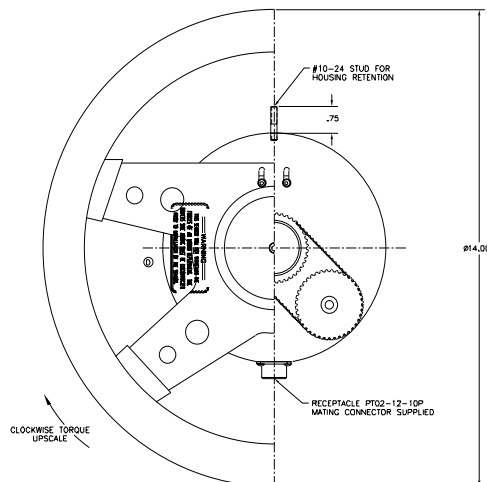

DWG