



Model TS11 Flange Style Reaction Torque Transducer

Why the Interface model TS11 Flange Style Torque Transducer is the best in class:

- Capacities from 10 to 20K Nm (88.5 to 177K lb-in)
- Compact
- Thru-hole design



TS11 Flange Style Torque Transducer

OPTIONS

100 % control signal (RCAL)

ELECTRICAL CONNECTION

6-PIN TS12 ELECTRICAL CONNECTION

Pin	Function
1	Excitation (-)
2	Excitation (+)
3	Shield
4	Signal (+)
5	Signal (GND)
6	Cal. Control (Option) Connect to Pin 2

SPECIFICATIONS

ACCURACY – (MAX ERROR)

Combined Error-% FS ±0.1
Nonrepeatability-% ±0.02

TEMPERATURE

Effect on Zero-% RO/°C ±0.02
Effect on Output-%/°C ±0.01
Rated Range-°C -5 to +45
Operating Range-°C -15 to +55

ELECTRICAL

Torque Output-mV/V
10 Nm..... 0.5
25 to 20K Nm 1.0
Excitation Voltage-VDC MAX12
Bridge Resistance-Ohm350
Electrical Connection6 pin

MECHANICAL

Safe Overload-% RO 150
Angular Deflection at Rated Torque-°<0.2
Cyclic Load Rating-% RO.....±70 peak
Material Stainless steel

TS11 Flange Style Reaction Torque Transducer - Capacities 10 to 20,000 Nm

DIMENSIONS

Nominal Torque										
Capacity (Nm)	10, 25, 50, 100, 200		500, 1K		2K		5K		10K, 20K	
Equivalent (lb-in)	8.85, 221, 443 885, 1.77K		4.43K, 8.85K		17K		44.3K		88.5K, 177K	
	inch	mm	inch	mm	inch	mm	inch	mm	inch	mm
①	2.56	65	3.15	80	3.94	100	3.94	100	4.88	124
②	M8, 6 places		M10, 8 places		M12, 12 places		M12, 12 places		M24, 8 places	
③	2.28	58	3.23	82	3.94	100	3.94	100	8.43	210
④	2.76	70	3.94	100	5.12	130	5.12	130	10.24	260
⑤	0.47	12	0.59	15	0.79	20	0.79	20	1.26	32
⑥	0.7874/ 0.7866	20 H7	0.7874/ 0.7866	20 H7	2.9528/ 2.9516	75 H7	2.9528/ 2.9516	75 H7	4.1139/ 4.1325	105 H7
⑦	0.39	10	0.71	18	0.79	20	-	-	4.13	105
⑧	1.30	33	1.56	39.5	1.77	45	1.77	45	2.66	67.5
⑨	1.77	45	2.36	60	3.15	80	3.15	80	5.71	145
⑩	60°		45°		30°		30°		45°	



TS11 Flange Style Torque Transducer

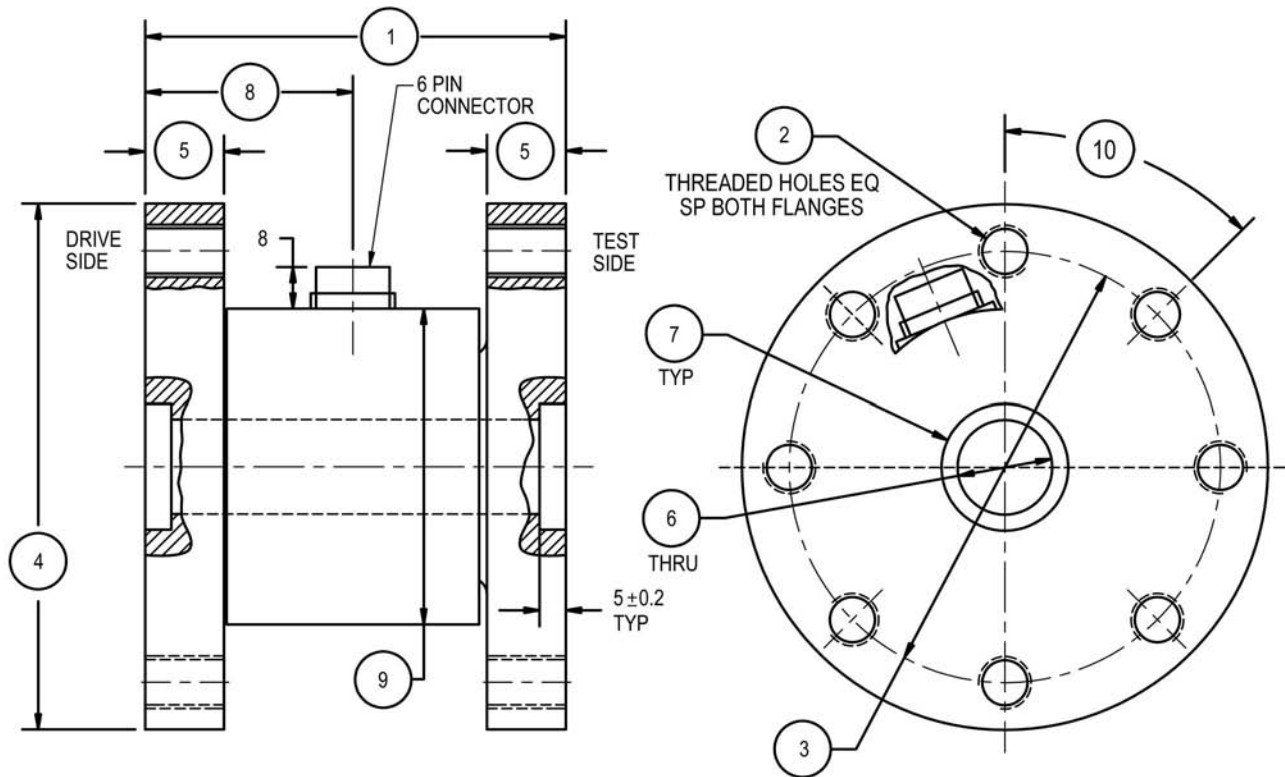

Dimensions in mm