

AST4310 Class 1 Div 2 Groups A, B, C, D Non-Incendive



Media Isolated, Field Adjustable Pressure Sensor

Overview

The AST4310 is a media isolated, field adjustable pressure transmitter suitable for use in hazardous areas. Protected by a Viton O-ring, this transmitter's two potentiometers have the ability to adjust the zero and span output signals up to $\pm 5\%$ [of the full scale pressure]. Additionally, the AST4310 offers access points through the housing of the transmitter in order to simplify adjustments after installation. Complete with a wide range of threads, pressure ranges and output signals, the AST4310 is the solution for pressure measurement when adjust ability is necessary.

Benefits

- UL/cUL 1604 (CSA 213) Class 1 Div 2 Groups A, B, C, D
- High Strength Stainless Steel Construction
- No Oil, Welds or Internal O-rings
- Wide Operating Temperature Range
- Ranges from Vacuum to 10,000 PSI
- Low Static and Thermal Errors
- Unparalleled Price and Performance
- Compatible with Wide Range of Liquids and Gases
- EMI/RFI Protection

Applications

- Refrigeration
- Industrial OEM Equipment
- Pressure Instrumentation
- Gas Compression & Storage
- Oxygen Delivery Systems
- Water Management
- Oil & Gas Platforms
- Process Control
- Test Stands
- Hydrogen Fuel (316L)

Electrical Data		
Output	4-20mA	1-5VDC
Excitation	10-28VDC	10-28VDC
Output Impedance	>10k Ohms	<100 Ohms, Nominal
Current Consumption	20mA, typical	<10mA
Bandwidth	(-3dB): DC to 250 Hz	(-3dB): DC to 1kHz
Output Noise	-	<2mV RMS
Zero Offset	< $\pm 1\%$ of FS	< $\pm 1\%$ of FS
Span Tolerance	< $\pm 2\%$ of FS	< $\pm 1.5\%$ of FS
Output Load	0-800 Ohms @10-28VDC	10k Ohms, Min.
Reverse Polarity Protection	Yes	Yes



**ZERO & SPAN
ADJUSTABILITY**

Performance @25°C (77°F)	
Accuracy*	< $\pm 0.25\%$ BFSL (< $\pm 0.5\%$ for 7500 & 10000 PSI)
Stability (1 year)	$\pm 0.25\%$ FS, typical
Over Range Protection	2X Rated Pressure
Burst Pressure	5X or 20,000 PSI (whichever is less)
Pressure Cycles	> 100 Million

* Accuracy includes non-linearity, hysteresis & non-repeatability

Environmental Data	
Temperature	
Operating	-40 to 85°C (-40 to 185°F)
Storage	-40 to 100°C (-40 to 212°F)
Thermal Limits	
Compensated Range	0 to 55°C (30 to 130°F)
TC Zero	< $\pm 1.5\%$ of FS
TC Span	< $\pm 1.5\%$ of FS
Other	
Shock	100G, 11 msec, 1/2 sine
Vibration	10G peak, 20 to 2000 Hz.
EMI/RFI Protection	Yes
Rating	IP-66



+33 (0)1 46 91 93 32 **Capteurs et Systèmes de mesure**

59, rue Émile Deschanel - 92400 COURBEVOIE - France - Fax : 33 (0)1 46 91 93 39 - contact@pm-instrumentation.com

Ordering Information

AST4310 A 00500 P 3 L 1 000

Series Type

Process Connection

A=1/4" NPT Male
 C=1/4" BSPP Male
 I= 1/4" NPT Female
 P=1/2" NPT Male

Pressure Range

Insert pressure range code from chart

Pressure Unit

B= Bar
 K= kg/cm²
 P= PSI

Outputs

3= 1-5V
 4= 4-20mA (2 wire loop powered)

Electrical* (Standard Conduit is 1/2-14 Male NPT)

I= DIN 43650A
 L= Conduit fitting, Cable 2 ft. (0.6 m)
 M= Conduit fitting, Cable 4 ft. (1.2 m)
 N= Conduit fitting, Cable 6 ft. (1.8 m)
 P= Conduit fitting, Cable 10 ft. (3.0 m)

Wetted Material

1=316 L

Options

000= No special options

Pressure Ranges*

PSIG Measurement Range	Pressure Range Code	BARG Measurement Range	Pressure Range Code
-14.7 to 30**	V0030**	-1 to 2**	V0002**
0-25	00025	0-2	00002
0-50	00050	0-5	00005
0-100	00100	0-10	00010
0-200	00200	0-20	00020
0-250	00250	0-50	00050
0-300	00300	0-100	00100
0-500	00500	0-250	00250
0-1,000	01000	0-350	00350
0-1,500	01500	0-500	00500
0-2,500	02500	0-700	00700
0-3,000	03000		
0-5,000	05000		
0-7,500	07500		
0-10,000	10000		

*Typical ranges. All ranges between 0-25 and 0-10,000 PSI available.
 **Compound ranges up to -14.7 to 500 PSI available. Please consult factory.

* Wiring information available at: <http://www.astensors.com/mediacenter.php>

Dimensional Data

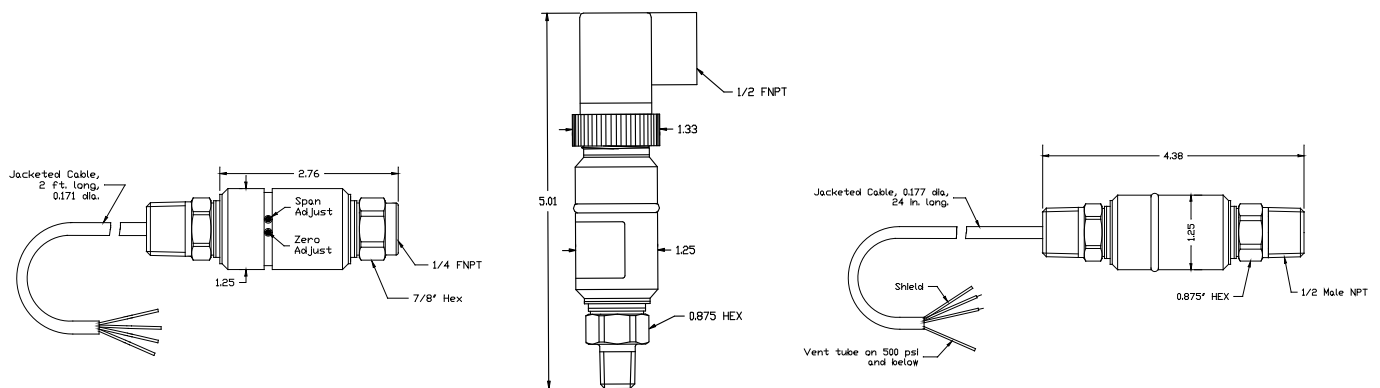

Warranty

Workmanship - AST, Inc. pressure transmitters have a limited one-year warranty to the original purchaser. AST, Inc. will replace or repair, free of charge, any defective transmitter. This warranty does not apply to any units that have been modified; misused, neglected or installed where the application exceeds published ratings. AST's sensors are made with pride in New Jersey, USA. If in the area please feel free to stop by for a visit!

Installation/Applications - The purchaser is responsible for media compatibility, functional adequacy, and correct installation of the transmitter.