

Model 3200 Standard Stainless Steel Load Cell

Why the Interface model 3200 Standard Stainless Steel Load Cell is the best in class:

- Proprietary Interface temperature compensated strain gages
- Hermetically sealed cell
- Performance to .05%
- Compact size
- High 4 mV/V output
- Eccentric load compensated
- .0008%/°F temp. effect on output
- Low deflection
- Shunt calibration
- Barometric compensation

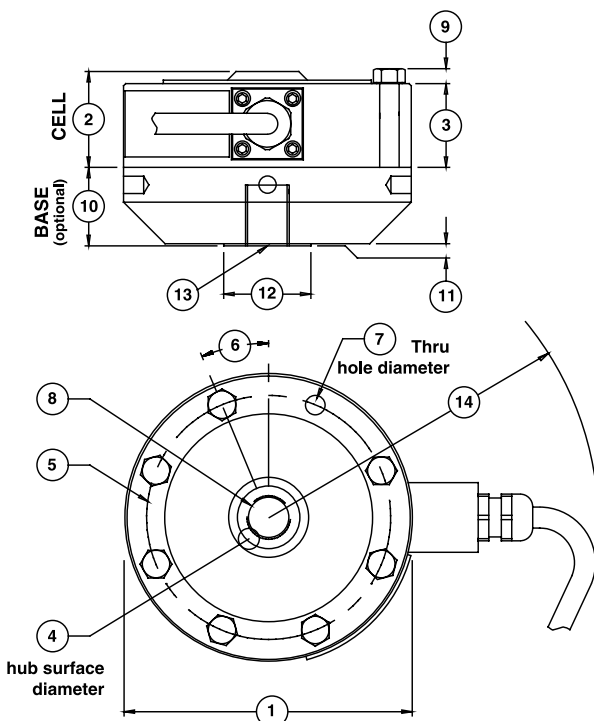
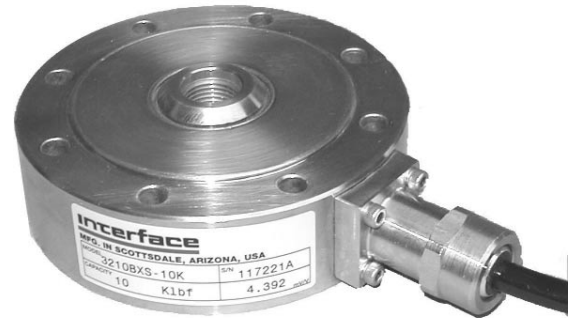

DIMENSIONS

See Drawing	MODEL					
	3210		3220		3232	
	CAPACITY (lbf)					
	2.5K, 5K, 10K		25K, 50K		100K	
	inch	mm	inch	mm	inch	mm
①	4.13	104.9	6.06	153.9	8.00	203.2
②	1.38	35.1	1.75	44.5	2.50	63.5
③	1.20	30.5	1.58	40.0	2.20	55.9
④	0.90	22.9	1.97	50.0	3.14	79.8
⑤	3.50	88.9	5.13	130.3	6.50	165.1
⑥	22.5°	22.5°	15.0°	15.0°	11.25°	11.25°
⑦	0.28	7.10	0.41	10.4	0.53	13.5
⑦	8 places		12 places		16 places	
⑧	5/8-18 UNF-3B 1.12 in deep		1 1/4-12 UNF-3B 1.40 in deep		1 3/4-12 UNF-3B 2.15 in deep	
⑨	0.20	5.10	0.30	7.60	0.31	7.90
⑩	1.13	28.6	1.75	44.5	2.00	50.8
⑪	0.03	0.80	0.03	0.80	0.03	0.80
⑫	1.25	31.8	2.25	57.2	3.00	76.2
⑬	5/8-18 UNF-3B		1 1/4-12 UNF-3B		1 3/4-12 UNF-3B	
⑬	0.87 in deep		1.40 in deep		1.75 in deep	
⑭	4.80	121.9	5.52	140.2	5.30	134.6

SPECIFICATIONS

PARAMETERS	MODEL				
	3210	3210	3220	3220	3232
	CAPACITY (lbf)				
	2.5K, 5k	10k	25k	50k	100k
ACCURACY – (MAX ERROR)					
Static Error Band-% FS	±0.05	±0.05	±0.05	±0.05	±0.06
Nonlinearity-% FS	±0.05	±0.05	±0.05	±0.05	±0.05
Hysteresis-% FS	±0.06	±0.06	±0.06	±0.06	±0.06
Nonrepeatability-% RO	±0.01	±0.01	±0.01	±0.01	±0.01
Creep, 20 min-%	±0.025	±0.025	±0.025	±0.025	±0.025
Side Load Sensitivity-%	±0.25	±0.25	±0.25	±0.25	±0.25
Eccentric Load Sensitivity-%/in	±0.25	±0.25	±0.25	±0.25	±0.25
TEMPERATURE					
Compensated Range-°F	15 to 115	15 to 115	15 to 115	15 to 115	15 to 115
Compensated Range-°C	-10 to 45	-10 to 45	-10 to 45	-10 to 45	-10 to 45
Operating Range-°F	-65 to 200	-65 to 200	-65 to 200	-65 to 200	-65 to 200
Operating Range-°C	-55 to 90	-55 to 90	-55 to 90	-55 to 90	-55 to 90
Effect on Zero-%RO/°F – MAX	±0.0008	±0.0008	±0.0008	±0.0008	±0.0008
Effect on Output-%/°F – MAX	±0.0008	±0.0008	±0.0008	±0.0008	±0.0008
ELECTRICAL					
	(2.5K 2.0)				
Rated Output-mV/V (Nominal)	4.0	4.0	4.0	4.0	4.0
Excitation Voltage-VDC – MAX	20	20	20	20	20
Bridge Resistance-Ohm (Nominal)	350	350	350	350	350
Zero Balance-% RO	±1.0	±1.0	±1.0	±1.0	±1.0
Insulation Resistance-Megohm	5000	5000	5000	5000	5000
MECHANICAL					
Safe Overload-% CAP	±150	±150	±150	±150	±150
Deflection @ RO-inch	0.002	0.002	0.002	0.002	0.003
Optional Base-P/N	B302	B302	B303	B303	B312
Natural Frequency-kHz	6.6	9.4	6.5	7.0	5.8
Weight-lb	3.3	3.3	9.5	9.5	26
Calibration	T & C	T & C	T & C	T & C	T & C

OPTIONS

- Base (Recommended)
- Submersible Cable
- Compression Overload Protection
- Cable length (20 ft Standard)
- Multiple Bridge
- Standardized Output
- Transducer Electronic Data Sheet (TEDS)

ACCESSORIES

- Instrumentation
- Loading Hardware
- Load Button
- Top & Bottom Plates

Consult factory for more technical information

STANDARD CONFIGURATIONS

- Integral 20 ft Cable (32xxBFG-nn)
- Installed Base (-B suffix)



Optional base