

Série LCF 200

Accéléromètre linéaire

BEST OF CLASS



The Jewell LCF Series Accelerometer is a $\pm 0.5G$ to $\pm 5G$ device designed for applications where high levels of shock and vibration are present. LCF units are characterized by excellent turn on repeatability and very low hysteresis.

LCF-200 Series Flexure Suspension Servo Fluid Damped Accelerometer Specifications

Performance

Input Range, g (Note 1)	± 0.50	± 2.0	± 5.0
Full Range Output (FRO), volts $\pm 0.5\%$	± 5.0	± 5.0	± 5.0
Nonlinearity, % FRO max (Note 2)	0.05%	0.05%	0.05%
Scale Factor, volts/g nominal	10.0	2.50	1.00
Scale Factor Temp. Sens, PPM/ $^{\circ}C$ max	100	100	100
Bias, g max	0.005	0.005	0.005
Bias Temperature Sens, micro g/ $^{\circ}C$ max	100	100	100
Natural Frequency, Hz min (Note 3)	30	30	30
Bandwidth (-3 dB), Hz min	30	30	30
Input Axis Misalignment, $^{\circ}$ max	1.0	1.0	1.0
Resolution and Threshold, micro g max	10	10	10

Electrical

Input Voltage, VDC	± 12 to ± 18
Input Current, mA nominal	± 15
Output Impedance, ohms nominal	100
Noise, V_{rms} max	0.002

Environmental

Operating Temp Range	-40 to $+80^{\circ}C$
Survival Temp Range	-40 to $+90^{\circ}C$
Vibration	20 grms
Shock	1000g, 1 msec, $\frac{1}{2}$ sine
Seal	Epoxy

NOTE 1: Full Range is defined as "from negative to positive full input acceleration."

NOTE 2: Referenced to a best-fit straight line independent of misalignment.

NOTE 3: Output phase angle = -90° .

Applications

- Geophysical Testing
- Railcar Acceleration Control
- Platform Orientation

LCF-200 Series Flexure Suspension Servo Fluid Damped Accelerometer

Block Diagram

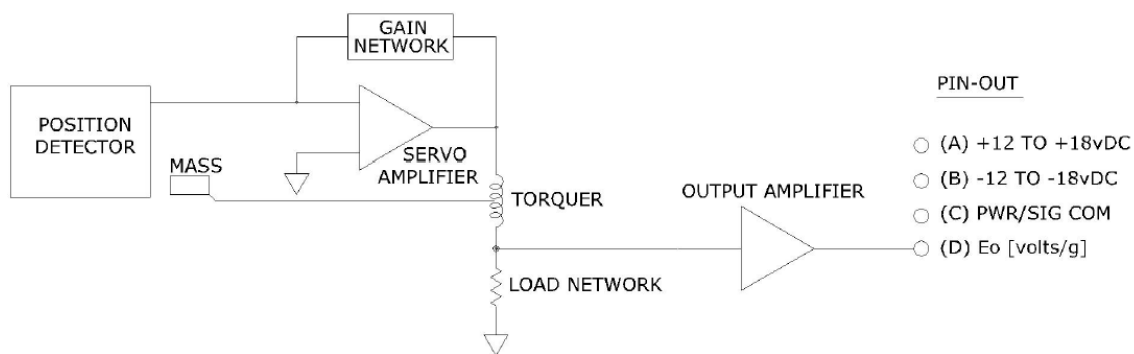

Outline Diagram

