

Wheel Torque Transducer

Models TW12.8, TW12.8ER

- 4000 lb-ft and 6000 lb-ft capacity
- Adapts to 14"-18" wheels
- Environmentally protected
- Temperature compensated
- Rugged stainless steel construction
- Enhanced resolution model available
- Configured to minimize magnetic sensitivity



Description

Michigan Scientific's *TW12.8* torque transducer is ideal for measuring wheel torque on both passenger cars and light duty trucks. Designed to attach to adapters that simulate production wheel rims, this model provides one channel of torque data and is completely weatherproof. The adapter system is fabricated by generating a profile of the original wheel rim and designing a hub and rim adapter, which fasten to the interior and exterior bolt circle respectively, and duplicate the critical dimensions of the original rim. The versatility of this system enables the torque transducers to be used with a variety of wheel rim designs.

Both the torque and combined steer/camber moment load ratings of the *TW12.8* transducer are 6000 lb-ft. A model with enhanced resolution is also available. The *TW12.8ER* has torque and combined steer/camber moment load ratings of 4000 lb-ft. The geometric configuration of these two models are identical, enabling them to be used with the same adapters.

High grade stainless steel material and weatherproof sealing combine to provide excellent resistance to corrosion and environmental conditions. Temperature compensation of the torque transducer ensures stable output throughout a wide temperature range; all wires are precisely located to reduce sensitivity to magnetic effects.

Specifications

	TW12.8	TW12.8ER
Maximum Load Capacity	6000 lb-ft (8136 N-m)	4000 lb-ft (5424 N-m)
Full Scale Load	6000 lb-ft (8136 N-m)	4000 lb-ft (5424 N-m)
Full Scale Output	1.5mV/V nominal	1.5mV/V nominal
Sensor	4 arm strain gage bridge	
Nonlinearity	0.1% of full scale output	
Hysteresis	0.05% of full scale output	
Repeatability	0.05% of full scale output	
Zero Balance	Within $\pm 5.0\%$ of rated output at zero load	
Bridge Resistance	180 Ω nominal	
Temperature Range, Compensated*	75°F to 200°F (24°C to 93°C)	
Temperature Effect on Zero	0.0008% full scale/ °F (0.0015% full scale/ °C)	
Temperature Range, Useable (Short Term)	-40°F to 300°F (-40°C to 149°C)	
Temperature Range, Useable (Long Term)	-40°F to 250°F (-40°C to 121°C)	
Excitation Voltage, Maximum	10V DC or AC rms	
Insulation Resistance, Bridge/Case	Exceeds 5000 M Ω	
Output Connector	Bendix PT02E-8-4P	
Mating Connector	Bendix PT06E-8-4S (SR)	

* Contact factory for other compensated ranges

8500 Ance Road
Charlevoix, MI 49720
Tel: 231-547-5511
Fax: 231-547-7070

Rev: 10/9/03

MICHIGAN SCIENTIFIC
corporation

<http://www.michsci.com>

Email: mcsinfo@michsci.com

321 East Huron Street
Milford, MI 48381
Tel: 248-685-3939
Fax: 248-684-5406



+33 (0)1 46 91 93 32

Capteurs et Systèmes de mesure

59, rue Émile Deschanel - 92400 COURBEVOIE - France - Fax : 33 (0)1 46 91 93 39 - contact@pm-instrumentation.com

Wheel Torque Transducer

TW12.8, TW12.8ER Configuration

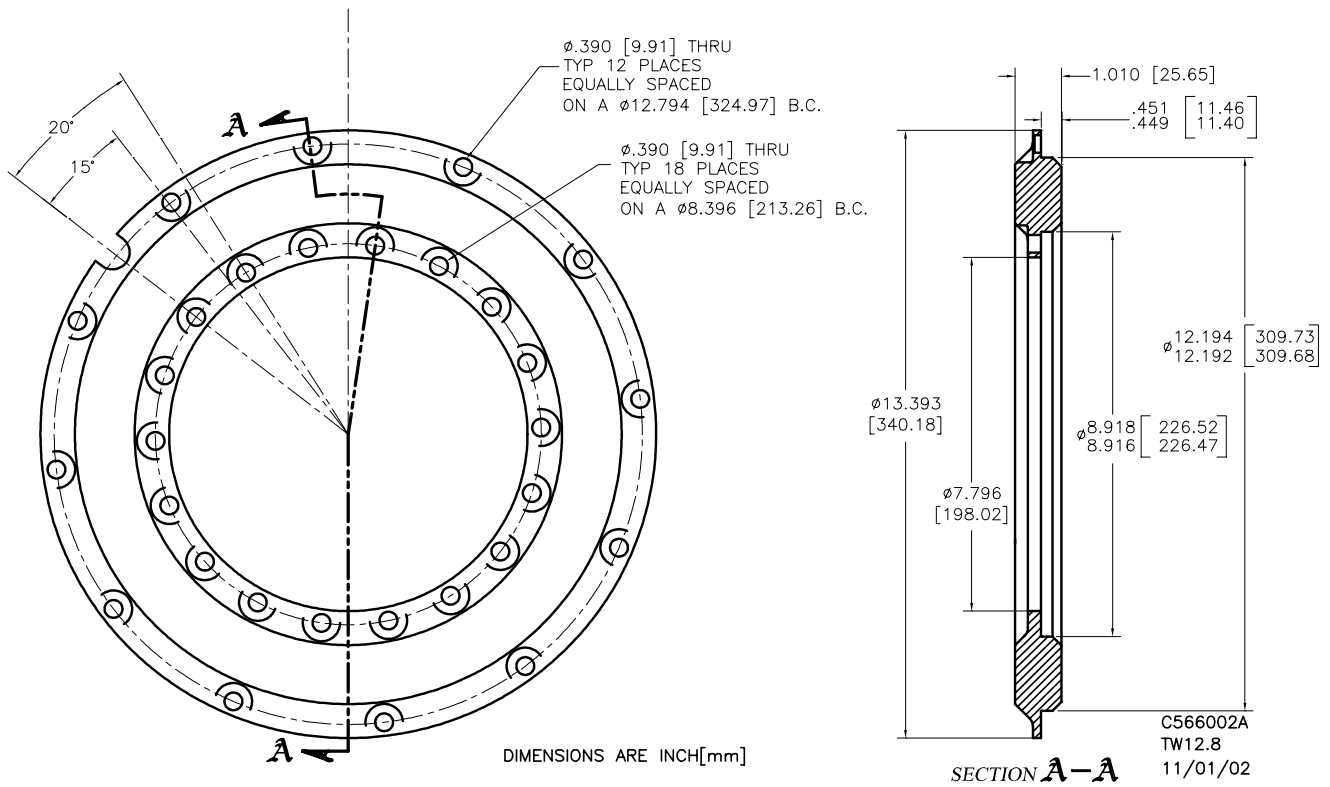

Options

Special units are available for high temperature applications.

Custom designs with alternative output sensitivities and load capacities may also be ordered.

Michigan Scientific offers a fully weatherproof slip ring, encoder, and amplifier instrumentation assembly to be used with all wheel torque transducers. Refer to the product literature section "Instrumentation Assemblies" for more information.



+33 (0)1 46 91 93 32 **Capteurs et Systèmes de mesure**

59, rue Émile Deschanel - 92400 COURBEVOIE - France - Fax : 33 (0)1 46 91 93 39 - contact@pm-instrumentation.com

8500 Ance Road
Charlevoix, MI 49720
Tel: 231-547-5511
Fax: 231-547-7070
Rev: 10/9/03

MICHIGAN SCIENTIFIC
<http://www.michsci.com>
Email: mscinfo@michsci.com
corporation

321 East Huron Street
Milford, MI 48381
Tel: 248-685-3939
Fax: 248-684-5406