



Model T8 LC Rotary Torque Transducer

Why the Interface model T8 LC Rotary Torque Transducer is the best in class:

- Capacities from 0.2 to 200 Nm (1.77 to 1.77K lb-in)
- Stainless steel shaft
- ± 5 VDC output
- 12-28 VDC supply
- Contactless



T8 LC Rotary Torque Transducer

SPECIFICATIONS

ACCURACY – (MAX ERROR)

Combined Error-% FS ± 0.25
 Nonrepeatability-% ± 0.05

TEMPERATURE

Effect on Zero-% RO/ $^{\circ}$ C ± 0.04
 Effect on Output-%/ $^{\circ}$ C ± 0.02
 Rated Range- $^{\circ}$ C +5 to +45
 Operating Range- $^{\circ}$ C 0 to +60

ELECTRICAL

Torque Output-VDC ± 5
 Bandwidth, Hz 1 kHz-3dB
 Supply Voltage-VDC 12 to 28
 Supply Current-mA 90
 Electrical Connection Integral cable, 3-ft

MECHANICAL

Safe Overload-% RO 180
 Cyclic Load Rating-% RO ± 70 peak
 Max Speed - rpm Varies with capacity, see table

Shaft Stainless steel
 Housing Aluminum

T8 INTEGRAL CABLE WIRING CODE		
Function	Description	Color
Supply (+)	12 to 28 VDC	Brown
Supply (GND)	0 VDC	Green
Signal (+)	± 5 VDC	Yellow
Signal (GND)	0 VDC	White
Shield	Shield	Shield

T8 LC ROTARY TORQUE TRANSDUCER PERFORMANCE PARAMETERS

CAPACITY (Nm)	MAX RPM	SPRINGRATE (Nm/rad)	MOMENT OF INERTIA, J (Kgxm ²)		MAX. THRUST LOAD (N)
			Drive Side	Test Side	
0.2	8,000	1.6	1.6×10^{-6}	1.0×10^{-6}	20
0.5	8,000	9.6	1.6×10^{-6}	1.0×10^{-6}	30
1	8,000	3.6×10^2	1.6×10^{-6}	1.1×10^{-6}	40
2	8,000	8.9×10^2	1.6×10^{-6}	1.1×10^{-6}	40
5	8,000	8.9×10^2	1.7×10^{-6}	1.1×10^{-6}	50
10	8,000	8.9×10^2	1.7×10^{-6}	1.1×10^{-6}	50
15	8,000	8.4×10^3	1.7×10^{-6}	1.1×10^{-6}	50
20	6,000	8.4×10^3	4.2×10^{-5}	2.1×10^{-5}	1,600
50	6,000	8.4×10^3	4.2×10^{-5}	2.1×10^{-5}	1,600
100	6,000	2.0×10^4	4.7×10^{-5}	2.7×10^{-5}	3,000
200	6,000	2.0×10^4	4.2×10^{-5}	2.7×10^{-5}	3,000

OPTIONS

Extra cable length

T8 LC Rotary Torque Transducer - Capacities 0.2 to 200 Nm

DIMENSIONS

Nominal Torque									
Capacity (Nm)	0.2, 0.5, 1, 2		5, 10, 15		20, 50		100, 200		
Equivalent (lb-in)	1.77, 4.43, 8.85, 17.7		44.3, 88.5, 133		177, 443		885, 1.77K		
	inch	mm	inch	mm	inch	mm	inch	mm	
①	3.94	100	3.94	100	5.51	140	6.30	160	
②	0.69	17.5	0.69	17.5	1.18	30	1.57	40	
③	0.67	17	0.67	17	1.14	29	1.53	39	
④	0.3148/ 0.3144	8g6	0.3935/ 0.3931	10g6	0.7087/ 0.7082	18g6	0.8659/ 0.8654	22g6	
⑤	0.59	15	0.59	15	0.79	20	0.79	20	
⑥	1.38	35	1.38	35	1.57	40	1.57	40	
⑦	1.81	46	1.81	46	2.56	65	2.56	65	
⑧	0.31	8	0.31	8	0.59	15	0.59	15	
⑨	1.02	26	1.02	26	1.37	34.8	1.37	34.8	
⑩	M4	M4	M4	M4	M5	M5	M5	M5	



T8 LC Rotary Torque Transducer

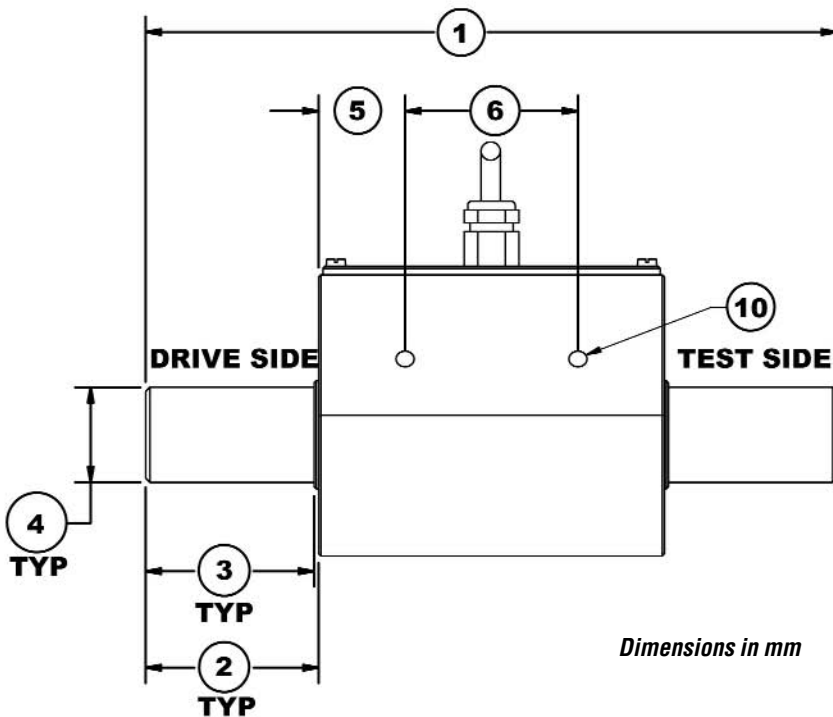

Dimensions in mm

