

Model T12 Square Drive Torque Transducer

Why the Interface model T12 Square Drive Torque Transducer is the best in class:

- Capacities from 0.10 to 5K Nm (0.88 to 44K lb-in)
- ± 5 VDC output
- 12-28 VDC supply
- Contactless-no slip rings



T12 Square Drive Torque Transducer

OPTIONS

Angle measurement - 360 pulse TTL, 2-tracks 90° offset, available on capacities up to 1,000 Nm only

± 10 V torque output

Enhanced accuracy - combined error $\pm 0.1\%$. See T2 Precision Rotary Torque Transducer data sheet

VDC or RS485 output

SPECIFICATIONS

ACCURACY – (MAX ERROR)	Standard	Enhanced
Combined Error–% FS	± 0.25	± 0.1
Nonrepeatability–%	± 0.05	± 0.02
TEMPERATURE		
Effect on Zero–% RO/°C	± 0.05	± 0.02
Effect on Output–%/°C	± 0.02	± 0.01
Rated Range–°C	+5 to +45	+5 to +45
Operating Range–°C	0 to +60	0 to +60
ELECTRICAL		
Torque Output–VDC	± 5	± 5
Bandwidth, Hz	1 kHz-3dB	3 kHz-3dB
Calibration Signal–% RO	100	100
Supply Voltage–VDC	12 to 28	12 to 28
Supply Current–mA	60	60
Electrical Connection	8 or 12-pin	8 or 12-pin
MECHANICAL		
Safe Overload–% RO	200	200
Cyclic Load Rating–% RO	± 70 peak	± 70 peak
Max Speed - rpm	See table	See table
Housing	Aluminum	Aluminum

T12 Square Drive Torque Transducer - Capacities to 20 Nm - 1/4" Drive

DIMENSIONS

Nominal Torque									
Capacity (Nm)	0.1	0.2	0.5	1	2	5	10	15	20
Equivalent (lb-in)	0.85	1.77	4.43	8.85	17.7	44.3	88.5	133	177
See Drawing									

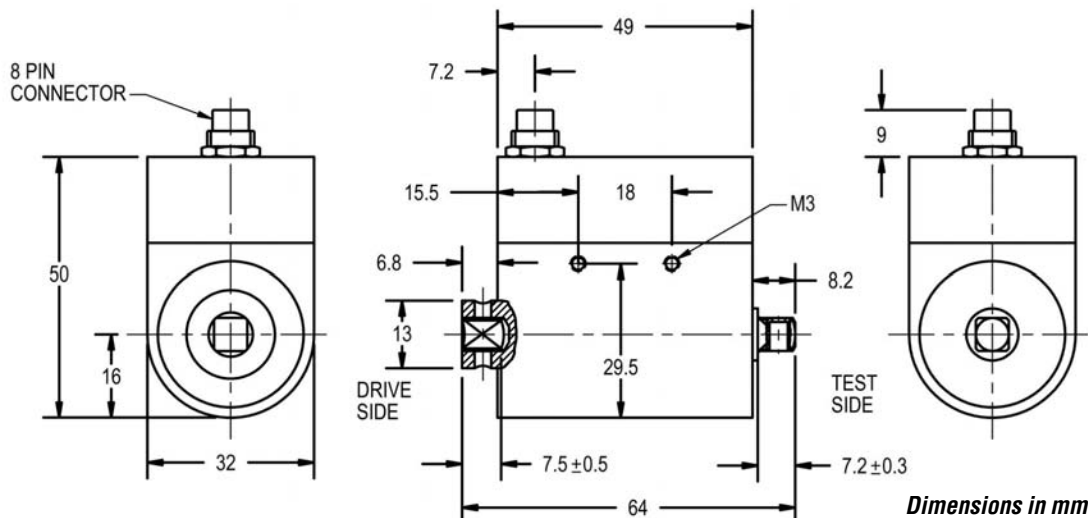

T12 Square Drive Torque Transducer - Capacities 63 to 1,000 Nm

DIMENSIONS

		Nominal Torque							
Capacity (Nm)	63		200		500		1K		
Equivalent (lb-in)	558		1.77K		4.43K		8.85K		
Square	3/8"		1/2"		3/4"		1"		
	inch	mm	inch	mm	inch	mm	inch	mm	
①	2.82	71.5	2.82	71.5	2.86	72.5	2.86	72.5	
②	0.87	22	1.17	29.8	1.73	44	2.13	54	
③	0.43	11	0.51	13	0.75	19	1.14	29	
④	0.44	11.2	0.63	15.9	0.94	23.9	1.13	28.6	
⑤	3.72	94.5	3.96	100.5	4.55	115.5	5.14	130.5	
⑥	0.40	10.7	0.61	15.4	0.90	22.9	1.09	27.6	
⑦	0.47	12	0.63	16	0.95	24	1.14	29	
⑧	2.32	59	2.32	59	2.99	76	2.99	76	
⑨	1.58	40	1.58	40	2.29	58	2.29	58	
⑩	0.79	20	0.79	20	1.14	29	1.14	29	
⑪	0.20	5	0.20	5	0.24	6	0.24	6	
⑫	1.64	41.5	1.64	41.5	1.16	29.5	1.16	29.5	
⑬	.591	15	.591	15	0.87	22	0.87	22	
⑭	0.47	12	0.47	12	0.59	15	0.59	15	



T12 Square Drive Torque Transducer

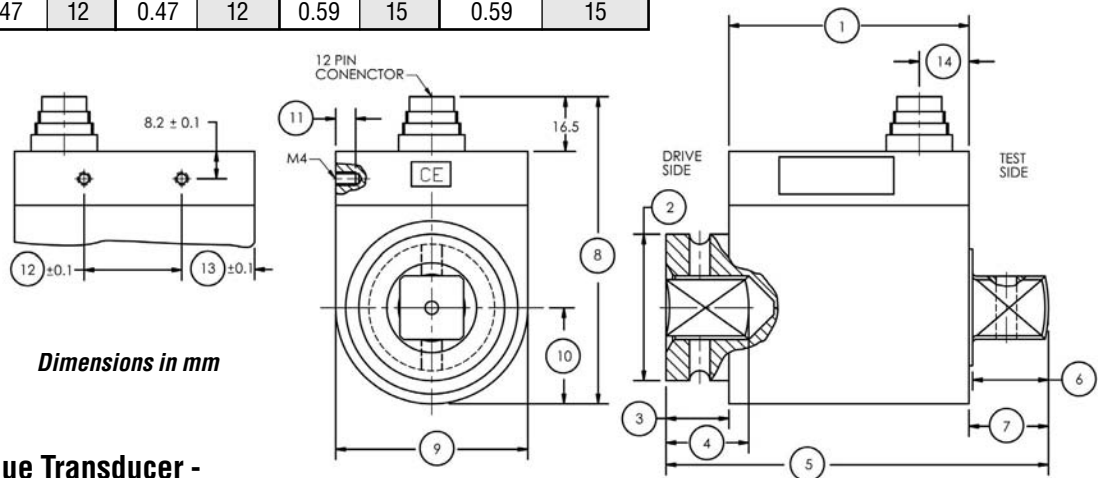

Dimensions in mm

T12 Square Drive Torque Transducer - Capacities 2K to 5K Nm - 1 1/2" Drive

DIMENSIONS

Nominal Torque		
Capacity (Nm)	2K	5K
Equivalent (lb-in)	17K	44.3K
See Drawing		

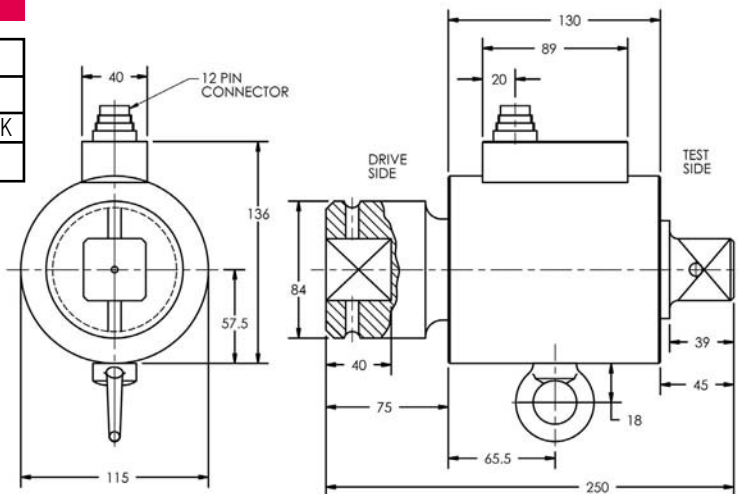

Dimensions in mm

T12 SQUARE DRIVE TORQUE TRANSDUCER PERFORMANCE PARAMETERS

CAPACITY (Nm)	SQUARE (INCH)	MAX RPM	SPRINGRATE (Nm/rad)	MOMENT OF INERTIA, J (Kgxm ²)		MAX. THRUST LOAD (N)
				Drive Side	Test Side	
0.1	0.25	3,000	1.0	2.1x10 ⁻⁶	2.3x10 ⁻⁷	15
0.2	0.25	3,000	1.0	2.1x10 ⁻⁶	2.3x10 ⁻⁷	20
0.5	0.25	3,000	5.9	2.1x10 ⁻⁶	2.3x10 ⁻⁷	30
1	0.25	4,000	5.9	2.1x10 ⁻⁶	2.3x10 ⁻⁷	40
2	0.25	4,000	3.0x10 ³	2.1x10 ⁻⁶	2.4x10 ⁻⁷	50
5	0.25	4,000	3.5x10 ³	2.1x10 ⁻⁶	2.4x10 ⁻⁷	50
10	0.25	4,000	7.3x10 ³	2.1x10 ⁻⁶	2.7x10 ⁻⁷	50
15	0.25	4,000	7.3x10 ³	2.1x10 ⁻⁶	2.7x10 ⁻⁷	100
20	0.25	4,000	7.3x10 ³	2.1x10 ⁻⁶	2.7x10 ⁻⁷	100
35	.375	3,000	8.6x10 ³	9.8x10 ⁻⁶	1.1x10 ⁻⁵	1,300
50	.375	3,000	1.0x10 ⁴	9.9x10 ⁻⁶	1.1x10 ⁻⁵	1,600
63	.375	3,000	1.1x10 ⁴	1.0x10 ⁻⁵	1.1x10 ⁻⁵	1,900
100	0.50	2,500	1.2x10 ⁴	1.6x10 ⁻⁵	1.1x10 ⁻⁵	2,600
160	0.50	2,500	1.5x10 ⁴	1.6x10 ⁻⁵	1.2x10 ⁻⁵	3,200
200	0.50	2,500	1.5x10 ⁴	1.6x10 ⁻⁵	1.2x10 ⁻⁵	3,200
300	0.75	2,500	8.8x10 ⁴	9.8x10 ⁻⁵	7.7x10 ⁻⁵	5,500
500	0.75	2,500	8.8x10 ⁴	9.8x10 ⁻⁵	7.7x10 ⁻⁵	7,500
1,000	1.00	1,500	1.3x10 ⁵	2.1x10 ⁻⁴	1.1x10 ⁻⁴	10,000
2,000	1.50	1,000	2.1x10 ⁵	3.5x10 ⁻³	1.8x10 ⁻³	18,000
3,000	1.50	1,000	2.3x10 ⁵	3.5x10 ⁻³	1.8x10 ⁻³	22,500
5,000	1.50	1,000	2.7x10 ⁵	3.5x10 ⁻³	1.8x10 ⁻³	32,000

ELECTRICAL CONNECTION

8-PIN T12 ELECTRICAL CONNECTION		
Pin	Function	Description
1	Supply (+)	12-28 VDC
2	Supply (GND)	0 VDC
3	Signal (+)	±5 VDC
4	Signal (GND)	0 VDC
5	Cal. Control	L < 2.0 / H > 3.5 V
6	Option Angle A	TTL
7	Option Angle B	TTL
8	NC	-

12-PIN T12 ELECTRICAL CONNECTION			12-PIN T12 RS485 OPTION	
Pin	Function	Description	Function	Description
A	NC	-	NC	-
B	Option Angle B	TTL	Option Angle B	TTL
C	Signal (+)	±5 VDC	NC	-
D	Signal (GND)	0 VDC	NC	-
E	Supply (GND)	0 VDC	Supply (GND)	0 VDC
F	Supply (+)	12-28 V	Supply (+)	12-28 VDC
G	Option Angle A	TTL	Option Angle A	TTL
H	NC	-	NC	-
J	NC	-	RS485 Option	RS485 (B)
K	Cal. Control	L < 2.0 V / H > 3.5 V	NC	-
L	NC	-	RS485 Option	RS485 (A)
M	Housing		Housing	