

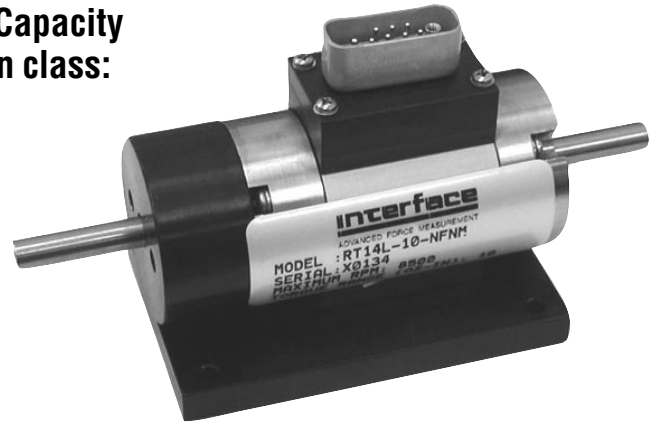

# Model RT13L & RT14L Low Capacity Rotary Transformer Torque Cell

**Why the Interface model RT13L & RT14L Low Capacity Rotary Transformer Torque Cells are the best in class:**

- 2X overload rating RT14L
- 4X overload rating RT13L
- Performance to 0.1%
- NIST Traceable dead weight calibration
- Bidirectional operation including stall
- Ferrite-free rotary transformer coupling
- Calibration & balance free of cable effects
- Unexcelled immunity to machinery magnetic fields
- mV/V output compatible with carrier amplifiers
- Titanium shaft



### OPTIONS\*

- Foot Mount (shown in photo)
- Speed Encoder with Line Driver
- Noise Hardening
- On-board Signal Conditioning\*\*

### ACCESSORIES\*

- Interconnect Cables
- Digital Readout (9850)

\*Please call for additional information  
\*\*Please consult factory for specifications

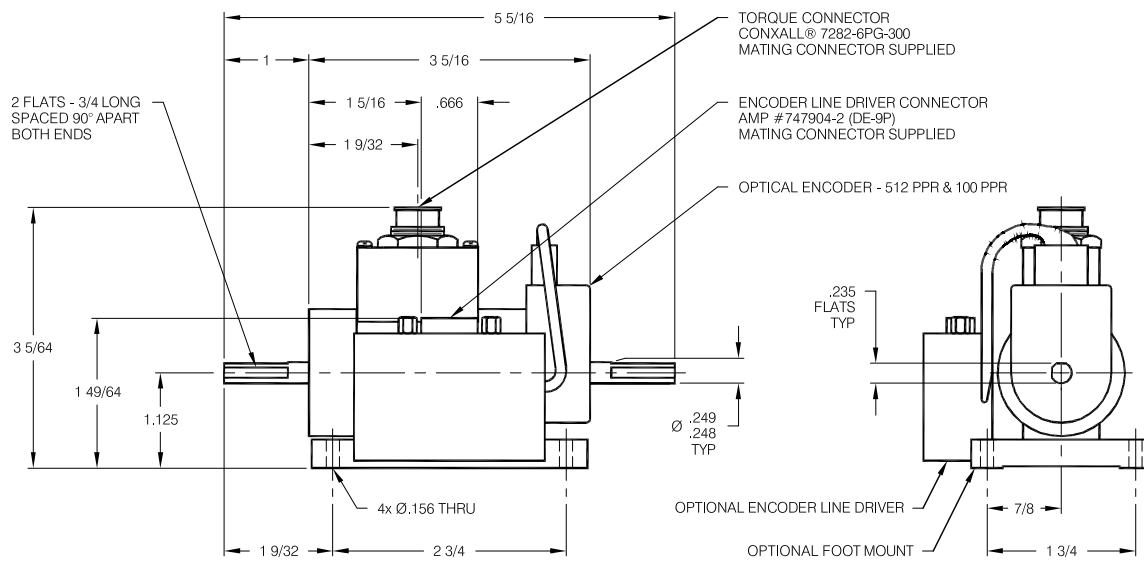

## SPECIFICATIONS

PARAMETERS	MODEL STANDARD
<b>ACCURACY – (MAX ERROR)</b>	
Combined Error–%FS	±0.1
Nonlinearity–%FS	±0.1
Hysteresis–%FS	±0.1
Nonrepeatability–%FS	±0.05
Stability, 6 Months–%FS	±0.15
Rotational Effect on Zero–%FS	±0.05
<b>TEMPERATURE</b>	
Effect on Zero–%FS	±0.002
Span–%FS	±0.002
Compensated Range–°F	+75 to +175
Minimum Usable Range–°F	-25 to +185
Storage Range–°F	-65 to +225
<b>ELECTRICAL</b>	
Fully bi-directional, dual output with common characteristics, as follows	
Clockwise (CW) Torque	+1.5 mV/V
Counterclockwise (CCW) Torque	-1.5 mV/V
Zero Balance	±1% of FS, nominal
Excitation (MAX.)	3 - 6 V rms, 3 kHz ±10% sine wave capable of driving a 90 ohm bridge
Readout	Strain gage carrier amplifier

Specifications apply to mV/V models only. When selecting the **ON-BOARD SIGNAL CONDITIONING** option please contact factory for specification details.

### Standard Ratings RT14L Series Low Capacity Non-Contact Torquemeters

TORQUE RANGE		TORQUE OVERLOAD		SPEED RATING	SHAFT STIFFNESS*		ROTATING INERTIA*		MAX. WT.
[oz-in]	[Nm]	[oz-in]	[Nm]	[rpm]	[oz-in/rad]	[Nm/rad]	[oz-in sec <sup>2</sup> ]	[Nm sec <sup>2</sup> ]	[lbs]
10	0.071	20	0.141	0 to ±25,000	336	2.37	1.82X10 <sup>-4</sup>	1.29X10 <sup>-6</sup>	1.5
20	0.141	40	0.2823	0 to ±25,000	528	3.73	1.83X10 <sup>-4</sup>	1.30X10 <sup>-6</sup>	1.5
50	0.353	100	0.706	0 to ±25,000	1,840	13.00	1.87X10 <sup>-4</sup>	1.33X10 <sup>-6</sup>	1.5
100	0.706	200	1.412	0 to ±25,000	4,224	29.82	1.93X10 <sup>-4</sup>	1.37X10 <sup>-6</sup>	1.5
200	1.412	400	2.825	0 to ±25,000	8,080	57.05	2.01X10 <sup>-4</sup>	1.43X10 <sup>-6</sup>	1.5

### Standard Ratings RT13L HIGH OVERLOAD Series Low Capacity Non-Contact Torquemeters

TORQUE RANGE		TORQUE OVERLOAD		SPEED RATING	SHAFT STIFFNESS*		ROTATING INERTIA*		MAX. WT.
[oz-in]	[Nm]	[oz-in]	[Nm]	[rpm]	[oz-in/rad]	[Nm/rad]	[oz-in sec <sup>2</sup> ]	[Nm sec <sup>2</sup> ]	[lbs]
10	0.071	40	0.283	0 to ±25,000	608	4.29	3.01X10 <sup>-4</sup>	2.14X10 <sup>-6</sup>	1.5
20	0.141	80	0.565	0 to ±25,000	1,616	11.41	3.07X10 <sup>-4</sup>	2.18X10 <sup>-6</sup>	1.5
50	0.353	200	1.412	0 to ±25,000	5,072	35.81	3.20X10 <sup>-4</sup>	2.27X10 <sup>-6</sup>	1.5
100	0.706	400	2.825	0 to ±25,000	8,864	62.59	3.32X10 <sup>-4</sup>	2.36X10 <sup>-6</sup>	1.5
200	1.412	800	5.649	0 to ±25,000	12,048	85.07	3.53X10 <sup>-4</sup>	2.51X10 <sup>-6</sup>	1.5

\*Stiffness and inertia are conservatively rated from shaft end to end.